

# Rotational Position Transducer

**0...5, 0...10 VDC Output**  
**Ranges: 0-45° to 0-200 Turns**  
**Industrial Grade**



# RT8510

## Specification Summary:

### GENERAL

Full Stroke Range Options ..... 0-0.125 to 0-200 turns  
 Output Signal Options ..... 0...5, 0...10 VDC  
 Accuracy ..... *see ordering information*  
 Repeatability .....  $\pm 0.05\%$  full stroke  
 Resolution ..... essentially infinite  
 Enclosure Material ..... powder-painted aluminum or stainless steel  
 Sensor ..... plastic-hybrid precision potentiometer  
 Potentiometer Cycle Life ..... *see ordering information*  
 Shaft Loading ..... up to 10 lbs. radial and 5 lbs. axial  
 Starting Torque (25°C) ..... 2.0 in.-oz., max.  
 Weight, Aluminum (Stainless Steel) Enclosure ..... 3 lbs. (6 lbs.) max.

### ELECTRICAL

Input ..... 14.5-40 VDC (10.5-40 VDC for 0...5 volt output)  
 Input Current ..... 10 mA maximum  
 Output Impedance ..... 1000 ohms  
 Maximum Load ..... 5000 ohms  
 Zero Adjustment ..... from factory set zero to 50% of full stroke range  
 Span Adjustment ..... to 50% of factory set span

### ENVIRONMENTAL

Enclosure ..... NEMA 4/4X/6, IP 67/68  
 Operating Temperature ..... -40° to 200°F (-40° to 90°C)  
 Vibration ..... up to 10 G's to 2000 Hz maximum

### EMC COMPLIANCE PER DIRECTIVE 89/336/EEC

Emission/Immunity ..... EN50081-2 / EN50082-2

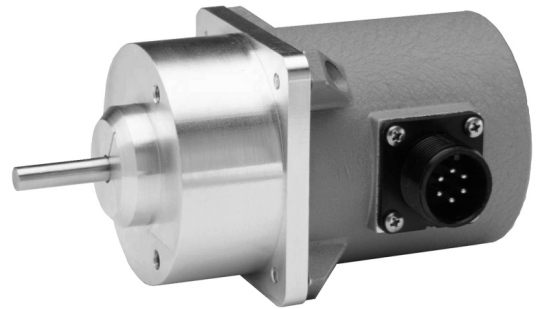

The RT8510 can operate from an unregulated 14.5 to 40 VDC power supply while providing a regulated output signal over it's full range from 1/8 of a turn up to 200 turns. It provides a 0 - 10 VDC position feedback signal proportional to the rotational position of the shaft

As a member of Celesco's innovative family of NEMA-4/ IP67 rotational transducers, the RT8510 offers numerous benefits including a zero and span adjust and a potentiometric sensor which provides an "absolute" feedback signal that is unaffected by power loss.

## Outline Drawing

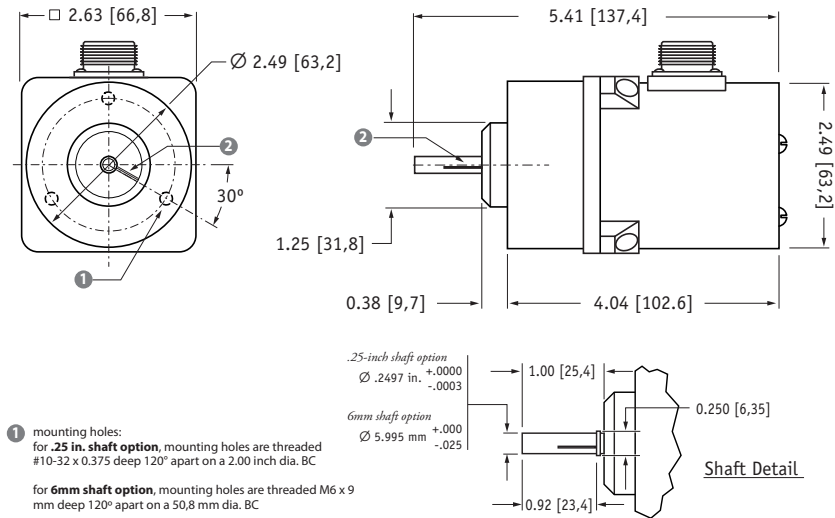

- 1 mounting holes:  
for **.25 in. shaft option**, mounting holes are threaded #10-32 x 0.375 deep 120° apart on a 2.00 inch dia. BC
- for **6mm shaft option**, mounting holes are threaded M6 x 9 mm deep 120° apart on a 50,8 mm dia. BC
- 2 reference mark:  
full counter-clockwise position - align mark on shaft to mark on face for start of measurement range

ALL DIMENSIONS ARE IN INCHES [MM]

## Output Signal

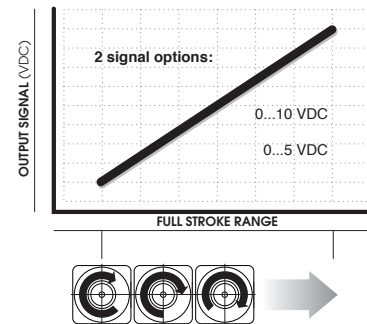

# RT8510 • Rotational Transducer: 0...5, 0...10 VDC Output Signal

## Ordering Information:

### Model Number:

**RT8510-** order code: **R** - **A** **B** **C** - **1** **D** **E** **F** **G** **0**

Sample Model Number:

**RT8510 - 0005 - 111 - 1110**

- R** range: 5 turns (clockwise shaft rotations)
- A** enclosure: aluminum
- B** shaft diameter: .25 inches
- C** mounting style: face mount
- F** output signal: 0...10 VDC signal increasing clockwise
- G** electrical connection: 6-pin plastic connector

### Full Stroke Range:

<b>R</b> order code:	<b>R125</b>	<b>OR25</b>	<b>OR50</b>	<b>0001</b>	<b>0002</b>	<b>0003</b>	<b>0005</b>	<b>0010</b>	<b>0020</b>
clockwise shaft rotations, min:	0.125	0.25	0.50	1	2	3	5	10	20
accuracy (% of f.s.):	1.25%	1.25%	0.5%	0.5%	0.5%	0.2%	0.2%	0.15%	0.15%
potentiometer cycle life*:	2.5 x 10 <sup>6</sup>	2.5 x 10 <sup>6</sup>	2.5 x 10 <sup>6</sup>	2.5 x 10 <sup>6</sup>	2.5 x 10 <sup>6</sup>	5 x 10 <sup>5</sup>	5 x 10 <sup>5</sup>	2.5 x 10 <sup>5</sup>	2.5 x 10 <sup>5</sup>





<b>R</b> order code:	<b>0030</b>	<b>0040</b>	<b>0050</b>	<b>0080</b>	<b>0100</b>	<b>0120</b>	<b>0140</b>	<b>0180</b>	<b>0200</b>
clockwise shaft rotations, min:	30	40	50	80	100	120	140	180	200
accuracy (% of f.s.):	0.15%	0.15%	0.15%	0.15%	0.15%	0.15%	0.15%	0.15%	0.15%
potentiometer cycle life*:	2.5 x 10 <sup>5</sup>	2.5 x 10 <sup>5</sup>	2.5 x 10 <sup>5</sup>	2.5 x 10 <sup>5</sup>	2.5 x 10 <sup>5</sup>	2.5 x 10 <sup>5</sup>	2.5 x 10 <sup>5</sup>	2.5 x 10 <sup>5</sup>	2.5 x 10 <sup>5</sup>

\*-number of times the sensor shaft can be cycled back and forth from beginning to end and back to the beginning before any measurable signal degradation may occur.

### Enclosure Material:

<b>A</b> order code:	<b>1</b>	<b>2</b>
	powder-painted aluminum	303 stainless steel

### Shaft Diameter:

<b>B</b> order code:	<b>1</b>	<b>2</b>	<b>3</b>	<b>4</b>
	0.25-in. diameter	6 mm diameter	0.25-in. dia. w/flats	6 mm dia. w/flats
	 .2497 in. (+.0000 -.0003)	 5.995 mm (+.000 -.025)	 0.33 in. ← → 0.025 in.	 8.4 mm ← → 0.64 mm

### Mounting Style:

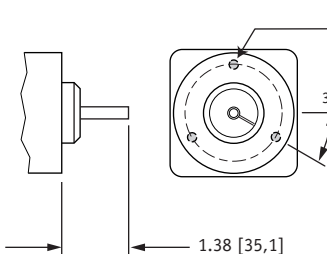
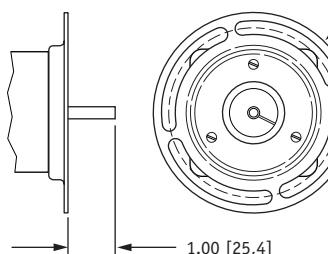
<b>C</b> order code:	<b>1</b>	<b>2</b>
	face mount	flange mount
	 1.38 [35,1] mounting holes spaced 120° apart on 2.00 [50,8] BC 6mm shaft option threaded M6 x 9 mm deep .25 in. shaft option #10-32 x 0.375 inch deep 30°	 1.00 [25,4] Ø 4.1 [104,14] .28 [7,1] wide mounting slot on a Ø3.50 [88,9] BC

IN [MM]

# RT8510 • Rotational Transducer: 0...5, 0...10 VDC Output Signal

## Ordering Information:

### Output Signals:

order code:	1	2	3	4
output signal options:	0...10 VDC	10...0 VDC	0...5 VDC	5...0 VDC
input voltage:	14.5...40 VDC		10.5...40 VDC	

Example:

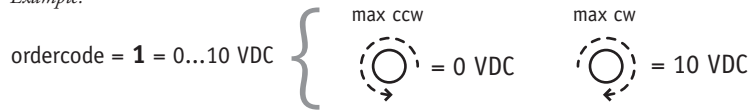

### Electrical Connection:

order code:	1	2	3	4
	6-pin plastic connector w/mating plug <b>IP 67, NEMA 4X**, 6</b>	10-ft. [3 M] waterproof cable <b>IP 67, NEMA 4X**, 6</b>	6-pin metal connector w/mating plug <b>IP 65, NEMA 4</b>	25-ft. [7.5 M] instrumentation cable <b>IP 67, NEMA 6</b>
	 3.0 in. [78 mm]		 2.4 in. [60 mm]	
	1/2 - 5/16" [14 - 8 mm] cable dia. 16 AWG max conductor size connector: MS3102E-14S-6P mating plug: MS3106E-14S-6S	10 ft. x 0.4-in. dia. [3 M x 10 mm dia.] 18 AWG, type SJTW	3/8-in. [9 mm] max cable dia. 16 AWG max conductor size connector: MS3102E-14S-6P mating plug: MS3106E-14S-6S	25 ft. x 0.2-in. dia. [7,5 M x 5 mm dia.] 24 AWG, shielded

order code:	5	6	7
	100-ft. [30 M] waterproof cable <b>IP 67, NEMA 4X**, 6</b>	10-ft. [3 M] <b>pressure tested*</b> waterproof cable <b>IP 68, NEMA 4X**, 6P</b>	100-ft. [30 M] <b>pressure tested*</b> waterproof cable <b>IP 68, NEMA 4X**, 6P</b>
	100 ft. x 0.4-in. dia. [30 M x 10 mm dia.] 18 AWG, type SJTW	10 ft. x 0.4-in. dia. [3 M x 10 mm dia.] 18 AWG, type SJTW	100 ft. x 0.4-in. dia. [30 M x 10 mm dia.] 18 AWG, type SJTW

#### 6-pin Mating Plug

pin	signal
A	input voltage
B	output signal
C	common

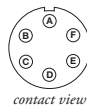

#### Waterproof Cable

color code	signal
WHITE	input voltage
GREEN	output signal
BLACK	common

#### Instrumentation Cable

color code	signal
RED	input voltage
GREEN	output signal
BLACK	common

Notes: { \* -Test pressure: 100 feet [30 meters] H<sub>2</sub>O (40 PSID); Test Medium: Air; Duration: 2 hours.  
\*\* -NEMA 4X applies to stainless steel enclosure only.

**Output Signal Selection:**

The output signal direction can be reversed at any time by simply changing the dip-switch settings found on the internal signal board. After the settings have been changed, adjustment of the Zero and Span trim pots will be required to precisely match signal values to the beginning and end points of the stroke.

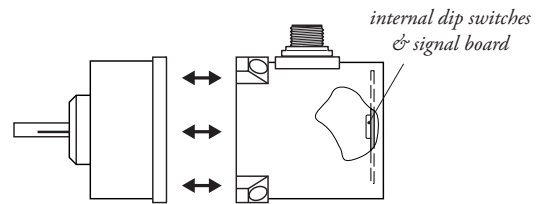
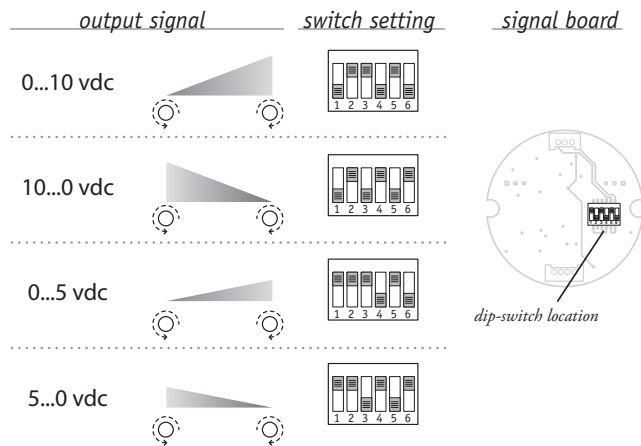

To gain access to the signal board, remove four Allen-Head Screws and separate the two case halves.