

2.5" [64 mm]

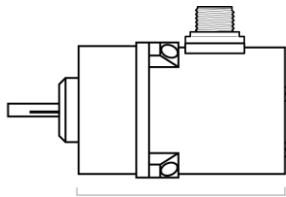

4.0" [102 mm]

Our model RT8DN communicates rotational position feedback via DeviceNET® to your programmable controller. The heart of this sensor is a precision plastic-hybrid position potentiometer which provides an “absolute” position and does not ever have to be reset to a “home” position after a power loss or planned shutdown.

This innovative sensor from Celesco, designed to meet tough NEMA-4 and IP67 environmental standards, is available in full-stroke measurement ranges of 1/8 to 200 turns.

### Output Signal

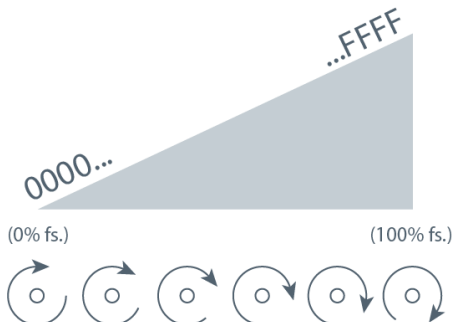

## RT8DN

0–45° to 0–200 Turns • DeviceNET®

**Industrial Grade Rotational Position Sensor**

**Absolute Rotary Position up to 200 turns**

**Aluminum or Stainless Steel Enclosure Options**

**IP68 / NEMA 6**

### General

<b>Full Stroke Range</b>	0-0.125 to 0-200 turns
<b>Electrical Interface</b>	CANbus ISO 11898
<b>Protocol</b>	DeviceNet Version 2.0
<b>Accuracy</b>	see ordering information
<b>Repeatability</b>	± 0.02% full stroke
<b>Resolution</b>	± 0.003% full stroke
<b>Enclosure Material Options</b>	powder-painted aluminum or stainless steel
<b>Sensor</b>	plastic-hybrid precision potentiometer
<b>Potentiometer Cycle Life</b>	see ordering information
<b>Shaft Loading</b>	up to 10 lbs. radial and 5 lbs. axial
<b>Starting Torque (25°C)</b>	2.0 in.-oz., max.
<b>Weight, Aluminum (Stainless Steel) Enclosure</b>	3 lbs. (6 lbs.) max.

### Electrical

<b>Input Voltage</b>	Bus Powered
<b>Input Current</b>	40 mA max.
<b>Address Setting (Node ID)</b>	0...63 set via DIP Switches (default setting: 63)
<b>Baud Rate</b>	125K, 250K or 500K set via DIP Switches
<b>EDS file</b>	available @ <a href="http://celesco.com/downloads">http://celesco.com/downloads</a>

### Environmental

<b>Enclosure</b>	NEMA 4/4X/6, IP 67/68
<b>Operating Temperature</b>	-40° to 200°F (-40° to 90°C)
<b>Vibration</b>	up to 10 g to 2000 Hz maximum

# RT8DN

0-45° to 0-200 Turns • DeviceNET®

## Outline Drawing

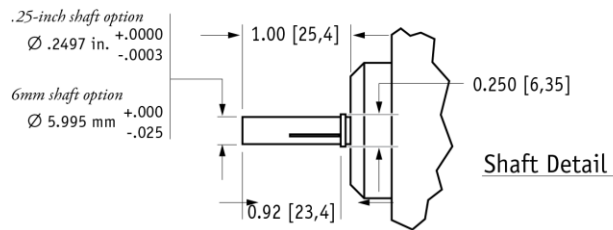
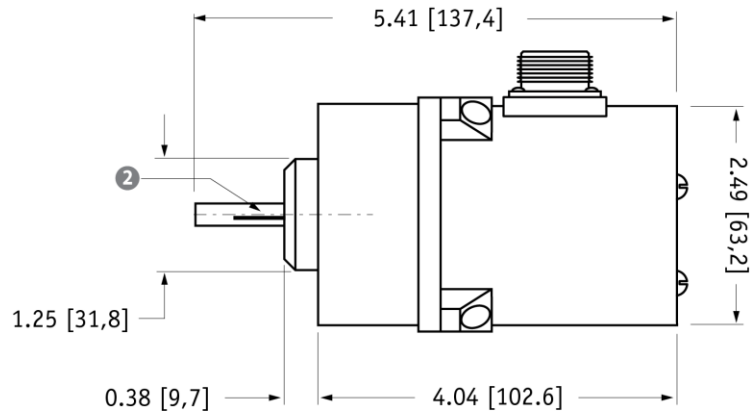
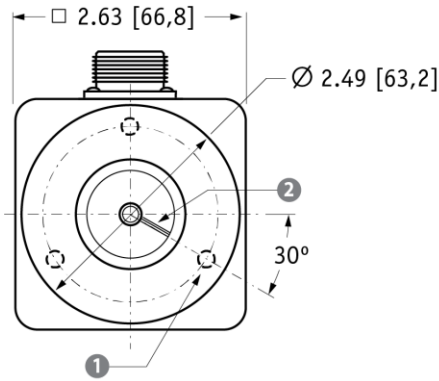

- 1 mounting holes:  
for .25 in. shaft option, mounting holes are threaded #10-32 x 0.375 deep 120° apart on a 2.00 inch dia. BC  
  
for 6mm shaft option, mounting holes are threaded M6 x 9 mm deep 120° apart on a 50,8 mm dia. BC
- 2 reference mark:  
full counter-clockwise position - align mark on shaft to mark on face for start of measurement range

DIMENSIONS ARE IN INCHES [MM]  
tolerances are ±0.02 in. [±0,5 mm] unless otherwise noted

## Ordering Information

### Model Number:

**RT8DN** -      -      -      -      -      -      -     

order code:      R      A      B      C      D      E      F

### Sample Model Number:

**RT8DN - 100 - AL - 25 - FL - 500 - TR - SC5**

- R range: 100 turns
- A enclosure: powder-painted aluminum
- B shaft: .25-in diameter
- C mounting style: flange
- D baud rate: 500 k bits/sec.
- E terminating resistor: yes
- F electrical termination: 5-meter cordset with straight plug

### Full Stroke Range:

R order code:	R125	R25	R50	1	2	3	5	10	20
clockwise shaft rotations, min:	0.125	0.25	0.50	1	2	3	5	10	20
accuracy (% of f.s.):	1.25%	1.25%	0.5%	0.5%	0.5%	0.2%	0.2%	0.15%	0.15%
potentiometer cycle life*:	2.5 x 10 <sup>6</sup>	2.5 x 10 <sup>6</sup>	2.5 x 10 <sup>6</sup>	2.5 x 10 <sup>6</sup>	2.5 x 10 <sup>6</sup>	5 x 10 <sup>5</sup>	5 x 10 <sup>5</sup>	2.5 x 10 <sup>5</sup>	2.5 x 10 <sup>5</sup>

R order code:	30	40	50	80	100	120	140	180	200
clockwise shaft rotations, min:	30	40	50	80	100	120	140	180	200
accuracy (% of f.s.):	0.15%	0.15%	0.15%	0.15%	0.15%	0.15%	0.15%	0.15%	0.15%
potentiometer cycle life*:	2.5 x 10 <sup>5</sup>	2.5 x 10 <sup>5</sup>	2.5 x 10 <sup>5</sup>	2.5 x 10 <sup>5</sup>	2.5 x 10 <sup>5</sup>	2.5 x 10 <sup>5</sup>	2.5 x 10 <sup>5</sup>	2.5 x 10 <sup>5</sup>	2.5 x 10 <sup>5</sup>

\*-number of times the sensor shaft can be cycled back and forth from beginning to end and back to the beginning before any measurable signal degradation may occur.

### Enclosure Material:

A order code:	AL	SS
	powder-painted aluminum	303 stainless steel

# RT8DN

0–45° to 0–200 Turns • DeviceNET®

## Shaft Diameter:

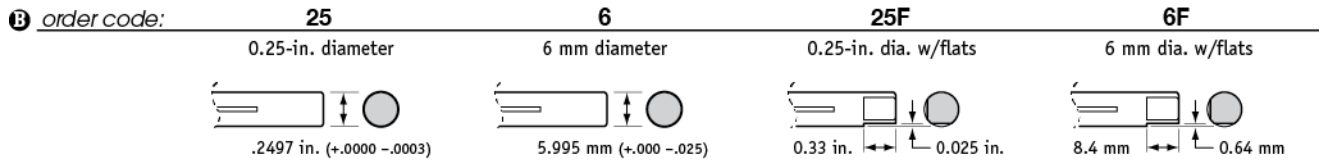

## Mounting Style:

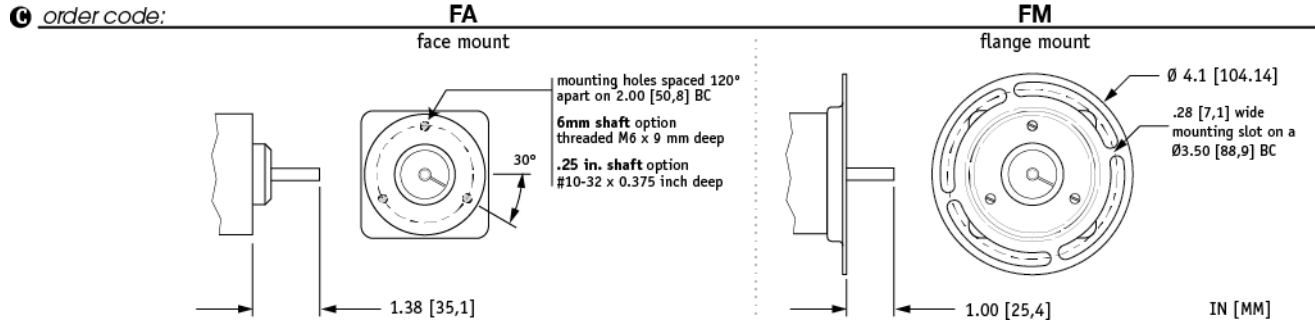

## Baud Rate:

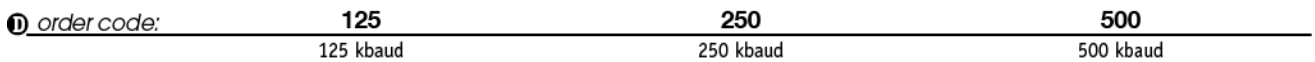

## Terminating Resistor:

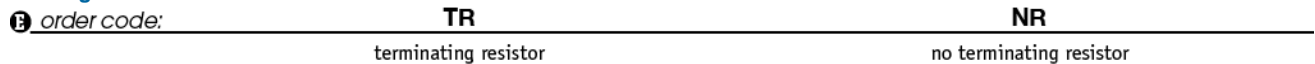

## Electrical Connection:

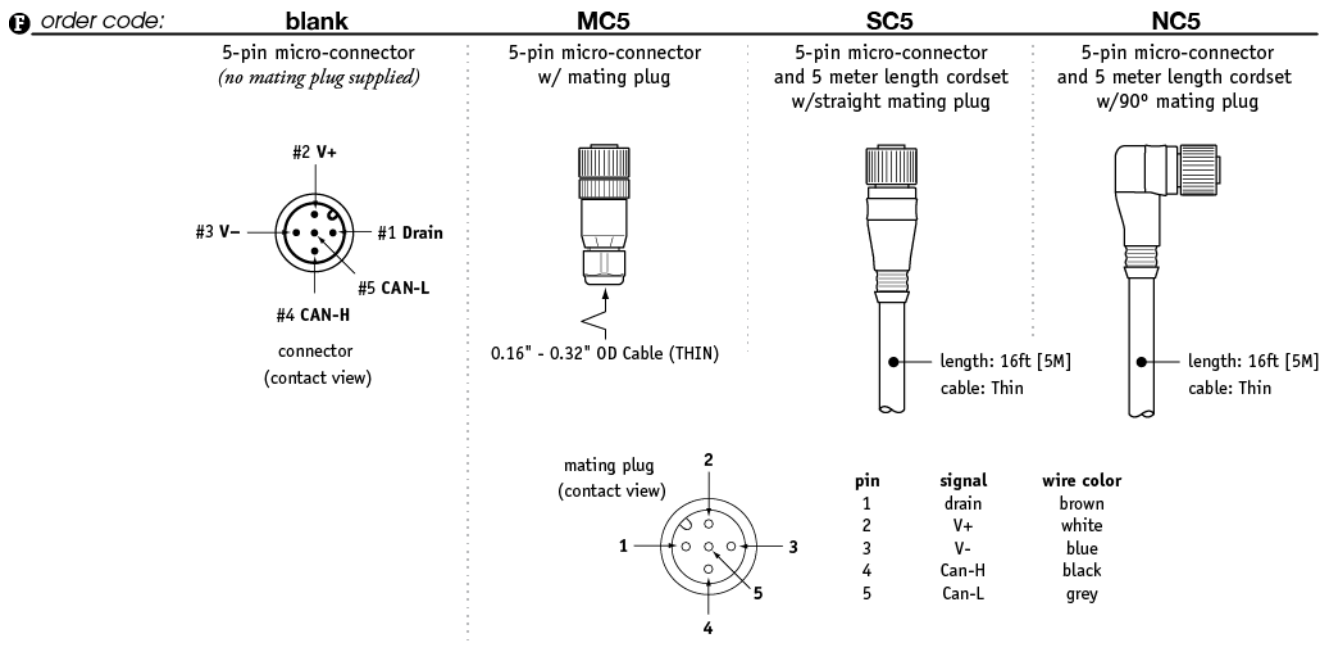

I/O Format

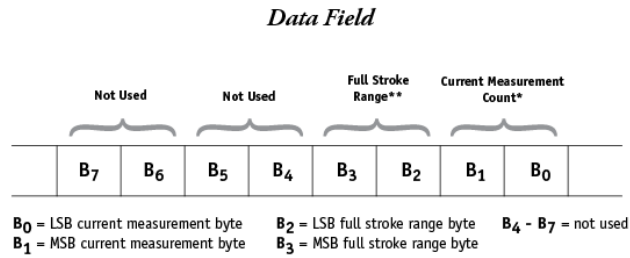
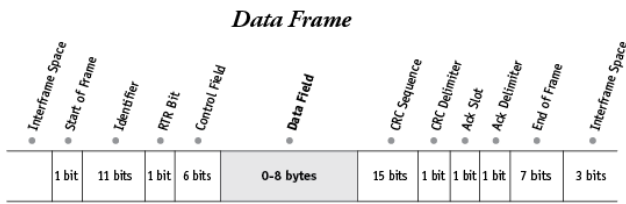

**\*Current Measurement Count**

The Current Measurement Count (CMC) is the output data that indicates the present position of the measuring cable.

The CMC is a 16-bit value that occupies the first two bytes (B<sub>0</sub> and B<sub>1</sub>) of the data field. B<sub>0</sub> is the LSB (least significant byte) and B<sub>1</sub> is the MSB (most significant byte).

The CMC starts at 0000H with shaft at the full counter-clockwise position (0° reference mark) and continues in the clockwise direction to the end of the stroke range stopping at FFFFH. This holds true for all ranges.

**\*\*Full Stroke Range**

The Full Stroke Range (FSR) is a 16-bit value in the data field that expresses the full range of the sensor in degrees. This value can be used to convert the actual count to units of measurement should the application require it.

The full stroke measurement range occupies the second two bytes (B<sub>2</sub> and B<sub>3</sub>) of the data field.

B<sub>2</sub> is the LSB (least significant byte) and B<sub>3</sub> is the MSB (most significant byte).

This value is expressed in degrees.

Example:

Hex Value	Decimal Equivalent	Full Stroke Range
0168	360	360 degrees

**Converting CMC to Degrees**

If required, the CMC can easily be converted to a rotational measurement expressed in degrees instead of counts.

This is accomplished by first dividing the CMC by 65,535 (total counts over the range) and then multiplying that value by the FSR:

$$\left( \frac{\text{CMC}}{65,535} \right) \times \text{FSR}$$

Example:

If the full stroke range is **1 turn (360 degrees)** and the current position is **OFF2 Hex (4082 Decimal)** then,

$$\left( \frac{4082}{65,535} \right) \times 360 \text{ deg.} = 22.4 \text{ degrees}$$

**Address Setting (Node ID), Baud Rate and Bus Termination Settings**

**Address Setting (Node ID)**

The Address Setting (Node ID) is set via 6 switches located on the 8-pole DIP switch found on the DeviceNET controller board located inside the transducer.

The DIP switch settings are binary starting with switch number 1 (= 2<sup>0</sup>) and ending with switch number 6 (= 2<sup>5</sup>).

DIP-1 (2 <sup>0</sup> )	DIP-2 (2 <sup>1</sup> )	DIP-3 (2 <sup>2</sup> )	DIP-4 (2 <sup>3</sup> )	DIP-5 (2 <sup>4</sup> )	DIP-6 (2 <sup>5</sup> )	address (decimal)
0	0	0	0	0	0	0
1	0	0	0	0	0	1
0	1	0	0	0	0	2
...	...	...	...	...	...	...
1	1	1	1	1	1	63

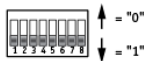

**Baud Rate**

The transmission baud rate may be either factory preset at the time of order or set manually at the time of installation.

The baud rate can be set using switches 7 & 8 on the 8-pole DIP switch found on the DeviceNET controller board located inside the transducer.

DIP-7	DIP-8	baud rate
0	0	125k
1	0	250k
0	1	500k
1	1	125k



**Bus Termination**

The setting of the internal bus termination resistor may be specified upon order or manually changed by the end user at the time of installation.

The bus termination resistor is activated setting switches 1 & 2 on the 2-pole DIP switch (located on the internal DeviceNET controller board) to the "ON" position.

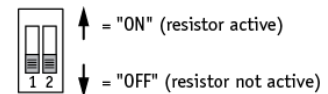

**DeviceNET Controller Board and DIP Switch Location**

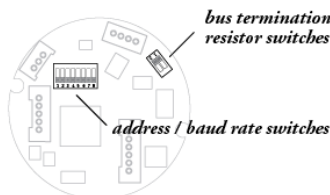

to gain access to the controller board, remove four Allen-Head Screws and separate case halves

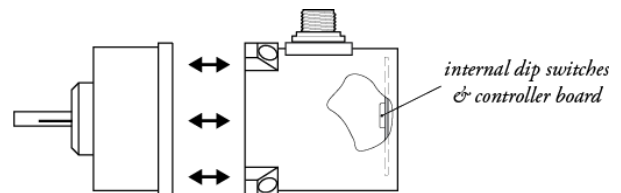

## RT8DN

0–45° to 0–200 Turns • DeviceNET®

---



**19 Waterman Ave. Toronto, Ont. M4B1Y2**  
**Tel: 416-445-5500 Fax: 416-445-1170**  
**Toll Free: 1-800-465-1600**  
**Email: [sales@intertechnology.com](mailto:sales@intertechnology.com)**  
**Website: [www.intertechnology.com](http://www.intertechnology.com)**

### [TE.com/sensorsolutions](http://TE.com/sensorsolutions)

Measurement Specialties, Inc., a TE Connectivity company.

Measurement Specialties, TE Connectivity, TE Connectivity (logo) and EVERY CONNECTION COUNTS are trademarks. All other logos, products and/or company names referred to herein might be trademarks of their respective owners.

The information given herein, including drawings, illustrations and schematics which are intended for illustration purposes only, is believed to be reliable. However, TE Connectivity makes no warranties as to its accuracy or completeness and disclaims any liability in connection with its use. TE Connectivity's obligations shall only be as set forth in TE Connectivity's Standard Terms and Conditions of Sale for this product and in no case will TE Connectivity be liable for any incidental, indirect or consequential damages arising out of the sale, resale, use or misuse of the product. Users of TE Connectivity products should make their own evaluation to determine the suitability of each such product for the specific application.

© 2015 TE Connectivity Ltd. family of companies All Rights Reserved.

RT8DN 12/01/2015