

Type 8692C5 ... 8692C50, 8692C5M1 ... 8592C50M1,

8692C SERIES, TRIAXIAL PiezoBEAM® ACCELEROMETERS

Designed for measuring structural response in modal applications, the 8692C series of triaxial accelerometers measure vibration in three, mutually perpendicular axes (x, y and z), simultaneously. The sensors feature high sensitivity and a low impedance voltage output. These lightweight accelerometers reduce mass loading on thin-walled structures. This series of accelerometers, each with an

integral four-pin connector, are designed for simplified and versatile installation. The unique, built-in magnet facilitates quick mounting; adhesive may be used for more permanent installations. As an option, the M1 version is available with 10-32 mounting thread in place of the internal magnet while the M9 version is available with color coded caps for axis identification. The 8692C series features

Continued

- Low impedance, voltage mode
- Unique integral mounting magnet
- Low cost, lightweight triaxial design
- High accuracy and stability
- Choice of ranges and sensitivities
- Excellent thermal stability
- Conforming to CE



Technical Data	Units	8692C5 8692C5M1	8632C10 8692C10M1	8692C50 8692C50M1
Acceleration Range	<i>g</i>	±5	±10	±50
Acceleration Limit	<i>g</i> _{pk}	±3	±16	±80
Threshold nom.	<i>g</i> _{rms}	120	280	1000
Sensitivity ±5% @ 3 <i>g</i> _{rms} & 100Hz	mV/ <i>g</i>	1000	500	100
Resonant Frequency mounted, nom.	kHz	9	22	22
Frequency Response ±5%	Hz	1 ... 3000	1 ... 5000	1 ... 6000
Phase Shift , < 5°	Hz	4 ... 2000	4 ... 2000	4 ... 4000
Amplitude Non-linearity	%FSO	±1	±1	±1
Time Constant nom.	s	1	1	1
Transverse Sensitivity	%	<1	<1	<1
Long Term Stability	%	±1	±1	±1
Environmental:				
Base Strain Sensitivity @ 250 µε	<i>g</i> /µε	<0.001	<0.001	<0.001
Shock Limit (0.2ms pulse width)	<i>g</i> _{pk}	5000	10000	10000
Temperature Coefficient of Sensitivity	%/°F	-0.02	+0.04	+0.04
	%/°C	-0.04	+0.08	+0.08
Temperature Range Operating (4 mA supply current)	°F	32 ... 149	32 ... 149	32 ... 149
	°C	0 ... 65	0 ... 65	0 ... 65
	°F	-10 ... 200	-10 ... 200	-10 ... 200
	°C	-23 ... 94	-23 ... 94	-23 ... 94
Storage				
Output:				
	Bias nom.	VDC	11	
	Impedance	Ω	<500	
	Voltage full scale	V	±5	
Current	mA	2		
Source:				
Voltage	VDC		20 ... 30	
Constant Current	mA		2 ... 20	
Impedance min.	kΩ		100	

1 *g* = 9.80665 m/s², 1 inch = 25.4 mm, 1 gram = 0.03527 oz, 1 lbf-in = 0.1129 Nm

Kistler Instrument Corporation reserves the right to discontinue or change specifications, designs or materials without notice consistent with sound engineering principles and quality practices.

Kistler Instrument Corporation, 75 John Glenn Drive, Amherst NY 14228
Phone 716-691-5100, Fax 716-691-5226, e-mail: sales.us@kistler.com, www.kistler.com

a wide frequency response with outstanding thermal stability and phase response. They are constructed of hard, anodized aluminum and sealed to withstand a wide range of environmental conditions. These sensors can be operated from an internal power source (IEPE, Integrated Electronic Piezo Electric) found in many FFT analyzers or from the wide range of Kistler Piezotron® power supply couplers. The low impedance voltage output allows for the use of low-cost cable and offers immunity to electrical noise.

Ordering Information

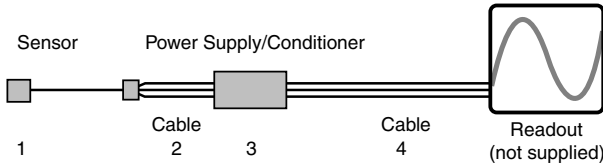

- Specify:
- 1 - 8692C... triaxial accelerometer with magnetic mounting specify range or 8692C...M1 accelerometer with 10-32 mounting thread
 - 2 - 1578A... extension cable, 4-pin Microtech pos. to 4-pin Microtech neg., specify length in meters
 - 3 - 1756B(X) cable, breakout cable 4-pin Microtech neg. to 3x BNC pos., specify length (X) = 0.5, 3, 10 meters
 - 4 - 5100 series couplers, or 5134 four-channel coupler
 - 4 - 1511... output cable, BNC pos. to BNC pos., specify length in meters

Technical Data	Unit	8692...
Construction:		
Sensing Element	type	ceramic bimorph/Bender
Housing	material	Al./ hard anodized
Sealing-housing connector	type	epoxy
Connector	type	4-pin Microtech Equivalent
Ground Isolation min.	MΩ	10
Weight	grams	16
Magnetic Holding Force nom.	lbf	2.75
for 8692	N	12.2
Mounting Torque M1 version	lbf-in (Nm)	12 (1.3)

Related Products

- 8630C series accelerometers, adhesive mount cube
- 8636C series accelerometers, 5-40 stud mount cube
- 8632C series accelerometers, single axis cube
- 8690C series accelerometers, triaxial cube
- 9720 series impulse hammers
- K-BEAM® accelerometers for very low frequency measurements

Supplied Accessories

- 8432 mounting wax
- 8402 mounting stud, 10-32 (included with M1 version)
- 8411 mounting stud, 10-32 to M6 (included with M1 version) shipped only outside N.A.

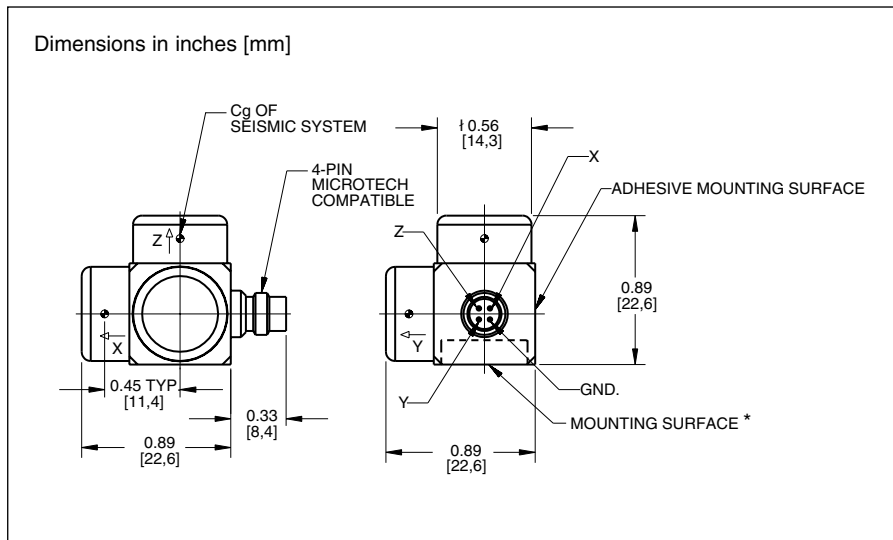

000-236e-10.02 (DBK8.8692e)