

Quartz Torque Sensor

Type 9039, 9049, 9069

-5 ... 5 N·m up to -200 ... 200 N·m

Quartz sensor for measuring a quasistatic or dynamic torque acting around the sensor axis.

Thanks to very high rigidity, a high natural frequency of the measuring device is attained.

- Wide measuring range
- Captures even the slightest dynamic changes in a large torque
- High rigidity

Description

The torque sensor consists of two steel disks, between which a ring is fitted which contains several shear-sensitive quartz plates. The crystal axes of the quartz plates are oriented tangentially to the peripheral direction and therefore yield a charge exactly proportional to the applied torque.

The quartz set is protected by the tightly welded and rust-proof steel case. The sensor is oil- and splashproof if a tightly fitted cable connector is used.

Application

The torque sensor is suitable for measuring a dynamic or quasistatic torque acting around the sensor axis.

Application Examples

- Adjusting torques of pneumatic screw-drivers
- Testing of screw connections
- Calibration measurements of manual torque wrenches
- Testing torsion of springs
- Measurements of friction clutches
- Measuring starting torques, variations in synchronization and torsional vibrations of fractional horsepower and stepping motors.
- Testing of rotary switch (product testing)

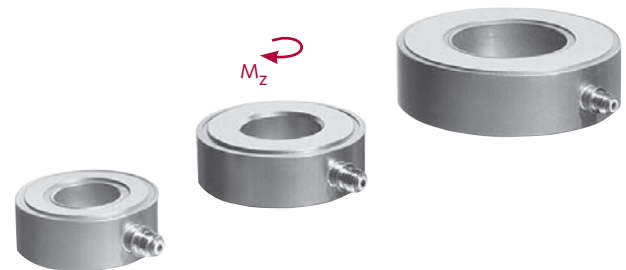

General Data

Linearity	% FSO	≤±1
Hysteresis	% FSO	≤1
Isolations resistance	TΩ	≥10
Temperature coefficient	%/°C	-0,02
Operating temperature range	°C	-150 ... 150

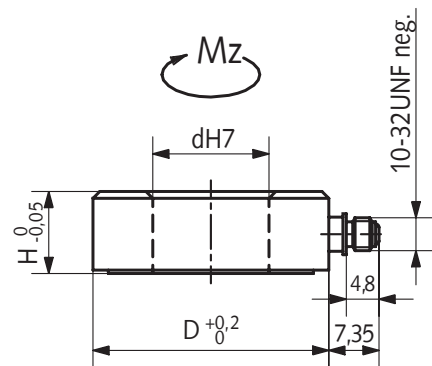

Fig. 1: Dimension quartz torque sensor, Type 9039 ... 9069

9039_000-111e-12.11

Technical Data

	Type	9039	9049	9069
Measuring range	N·m	-5 ... 5	-25 ... 25	-200 ... 200
Preloading force*	kN	15	25	120
Tightening torque MA*	N·m	≈12	≈25	≈200
Calibrated Ranges				
100 %	kN	-5 ... 5	25 ... 25	-200 ... 200
10 %	kN	-0,5 ... 0,5	2,5 ... 2,5	-20 ... 20
Overload	N·m	-6/6	-30/30	-240/240
Sensitivity	pC/N·m	≈-600	≈-250	≈-175
Threshold	N·cm	≈0,01	≈0,02	≈0,02
Max. bedding moment	N·m	13	20	200
Cross talk F → M	mN·cm/N	0,36	0,9	20
Rigidity cM	N·cm/μrad	≈7	≈12	≈50
Capacitance	pF	≈43	≈340	≈350
Dimensions				
d	mm	13	17	26,5
D	mm	28,5	36	52
H	mm	11	12	15
Weight	g	38	61	150

* with means of preloading elements Type 9420A...

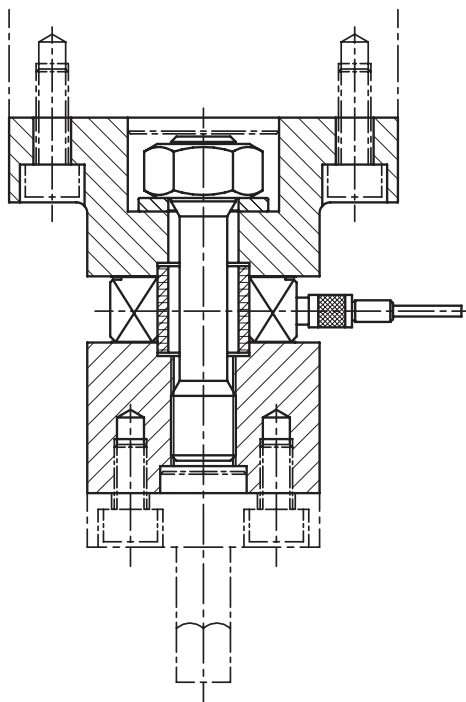

Fig. 2: Application: Testing of rotary switch.
Mounting of the torque sensor under preload
by means of preloading elements Type 9420A31/41/61

Mounting

The torque sensor must be mounted under elastic preload as the torque must be transmitted by static friction onto the front parts of the sensor.

Fig. 2 shows an example of preloading with a centered elastic preloading bolt.

When mounting the sensor, the mounting surfaces must be ground and the preloading bolt must be oriented perpendicular to these surfaces.

Scope of Delivery

- Torque Sensor
- Special grease

Type

1063

Accessories

- Preloading elements
see data sheet 9420A_000-192
- Cables
see data sheet 1631C_000-346

Ordering Code

- **Quartz torque sensor**
Measuring range -5 ... 5 N·m
- **Quartz torque sensor**
Measuring range -25 ... 25 N·m
- **Quartz torque sensor**
Measuring range -200 ... 200 N·m

Type

9039

9049

9049

9039_000-111e-12.11