

## SlimLine Sensor (SLS)

Type 9143B... up to 9147B...

### Measurement of Dynamic and Quasistatic Shear Forces –0,9 ... 0,9 kN up to 0 ... ±8 kN

Quartz sensor with extremely flat design for measuring dynamic and quasistatic shear forces in one direction. Maximum resolution, high rigidity, extremely small dimensions. Ideal for installation in structures. Welded construction with integrated connecting cable sealed in the case and with a selection of plug connectors.

SlimLine sensors are supplied **uncalibrated** and must be calibrated in situ **after** installation.

- Extremely small size with up to 8 kN measuring range (shear force)
- Flexible mounting in structures
- Sealed case (IP65)
- Integral non-detachable cable with Viton® sheath

#### Description

The sensor contains two quartz elements sensitive to shear force in one direction. The force to be measured is transmitted by stiction to the quartz elements and these produce an electrical charge directly proportional to the force applied.

The cable connection to the sensor case is tightly sealed to provide degree of protection IP65.

#### Application

The sensor is used in industrial manufacturing processes requiring measurement and partial monitoring of shear forces. In conjunction with a ControlMonitor this sensor is ideal for quality control and monitoring of large-scale industrial production. Its particularly slim profile makes it perfect for mounting in structures such as force plates, tools and machine frames. Where very large shear forces have to be measured, or positioning directly in the force flux is not possible, the sensor is shunt mounted. It then measures only part of the process force and the rest is shunted. This means a smaller measuring

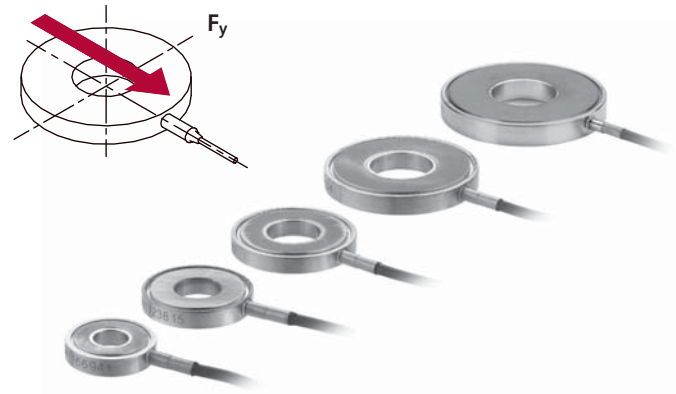

range than with direct shear force measurement can normally be used to provide a more cost-effective solution. Another advantage is the high overload protection provided by force shunt measurement.

#### Examples of Applications

- Monitoring of shear forces in machinery, tools and assembly processes.
- Construction of platforms and dynamometers with small dimensions.

#### Technical Data

Linearity (preloaded)	%FSO	≤±1
Hysteresis (preloaded)	%FSO	≤1
Response threshold	N	<0,01
Calibrated measuring ranges		not calibrated
Operating temperature range	°C	–20 ... 120
Degree of protection EN60529		IP65
Connector	optional	KIAG10-32 pos. Mini-Coax neg.

#### Other Technical Data

Basic Type	Range $F_y$ [kN]	Overload $F_y$ [kN]	Sensitivity [pC/N]	Rigidity (axial) [kN/μm]	Preloading force (axial) <sup>1)</sup> [kN]	External diameter D [mm]	Internal diameter d [mm]	Height H [mm]	Weight m [g]
9143B...	0 ... ±0,9	1,1	–6,5	≈2,5	9,0	16,0	6,1	3,5	3,0
9144B...	0 ... ±1,7	2,0	–7,5	≈5,6	17,0	20,0	8,1	3,5	5,0
9145B...	0 ... ±2,7	3,3	–7,5	≈7,0	27,0	24,0	10,1	3,5	7,0
9146B...	0 ... ±4,0	4,7	–7,5	≈8,0	40,0	30,0	12,1	4,0	14,0
9147B...	0 ... ±8,0	10,0	–8,1	≈16,0	80,0	36,0	14,1	5,0	27,0

<sup>1)</sup> Cannot be measured by the sensor

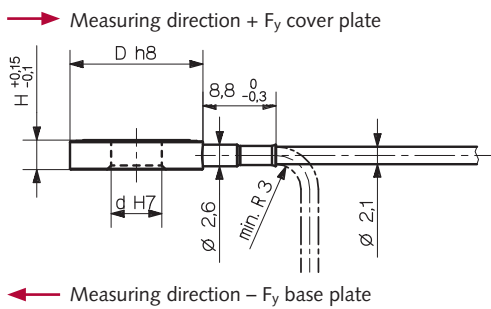

Fig. 1: Dimensions SlimLine Sensor

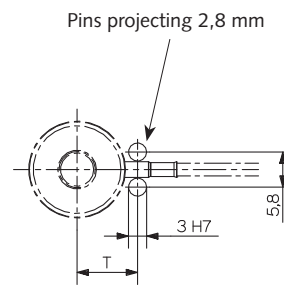

Fig. 2: Two pins prevent the sensor from turning

**Information for Installation**

for SL Sensor Type		9143B...	9144B...	9145B...	9146B...	9147B...
Thread M		M6	M8	M10	M12	M14
Bore d1	mm	6,4	8,4	10,5	13	15
Plate thickness A	mm	12	16	20	24	27
Distance T	mm	13	15	17	20	23
Max. tightening torque for preloading	N·m	10	23	46	79	135

**Installation**

A shear force sensor must always be fitted under preload, since the shear forces are transmitted by stiction. The contact surfaces with the sensor must be absolutely free of grease, finish machined and rigid. The adjacent table contains the most important information concerning preloading. Note: The stated tightening torque applies only to the screw thread M mentioned (lightly greased).

Markings on the sensor case facilitate its alignment. Two pins can be used to prevent the sensor from turning during its installation (Fig. 3).

**Basic Type Fitted with Set Screw**

Basic Type	Measuring Range $F_y$ [kN]	Preloading Force $F_v$ [kN]	Tightening Torque [N·m]
9143B...	0,9	9,0	10,0
9144B...	1,7	17,0	23,0
9145B...	2,7	27,0	46,0
9146B...	4,0	40,0	79,0
9147B...	8,0	80,0	135,0

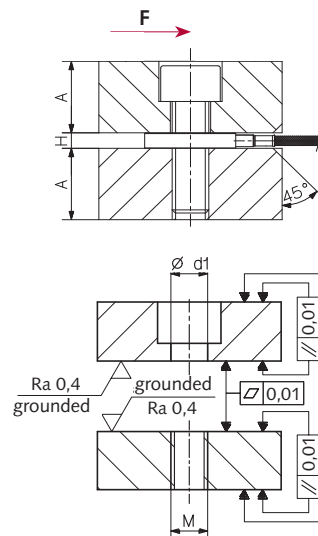

Fig. 3: Mounting dimensions with direct force measurement

9143B\_000-113e-09\_09

**Reduction in Measuring Range with Additional Bending Moment for SlimLine Sensors (SLS)**

Basic Type	max. Bending Moment $M_{b,zul}$ <sup>1)</sup> ( $F_z = 0$ ) [N·m]	Reduction of measuring range $F_y$ when allowable bending moment [kN/N·m] exceeded
9143B...	10,2	0,0456
9144B...	24,0	0,0369
9145B...	30,5	0,0290
9146B...	96,5	0,0231
9147B...	100,0	0,0201

<sup>1)</sup> The allowable bending moment  $M_{b,zul}$  must not be exceeded. If this is unavoidable in the particular application, the measuring range  $F_y$  must be simultaneously reduced as shown in the following example.

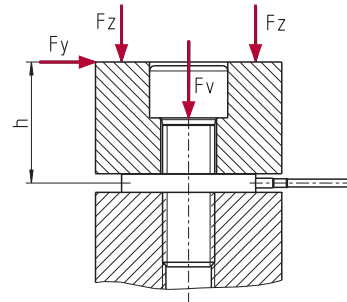

Fig. 4: Bending moment  $M_b = F_y \cdot h$

**Example**

A bending moment  $M_b$  of 35 N·m acts on a sensor Type 9144B... . What is the magnitude of the maximum measuring range  $F_y$ ?

The acting bending moment  $M_b$  is 35 N·m – 24 N·m = 11 N·m greater than the allowable value. This reduces the measuring range  $F_y$  from 1,70 kN by 11 N·m x 0,0369 kN/N·m = 0,41 kN to 1,29 kN.

**Calibration**

The preloading bolt needed for fitting the sensor forms a force shunt, i.e. the sensor measures only about 90 % of the entire force. Accordingly, the exact sensitivity of a sensor can only be determined after preloading.

**The SlimLine sensor is therefore delivered uncalibrated. Its sensitivity can be determined by calibration only after it has been fitted.**

**Installation Examples in Shear Force Plates**

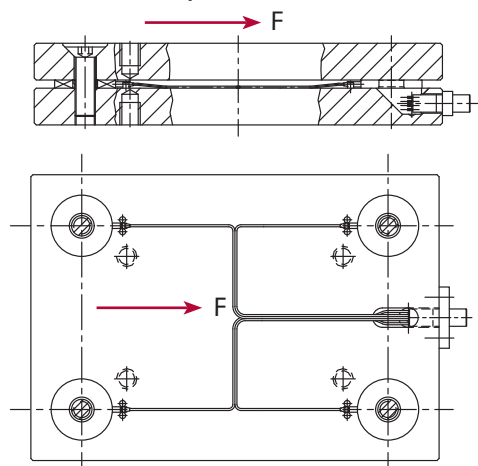

Fig. 5: Single-component dynamometer. Measurement of shear forces  $F_y$ . Note: two sensors must be fitted so that they are arranged around the connector axis.

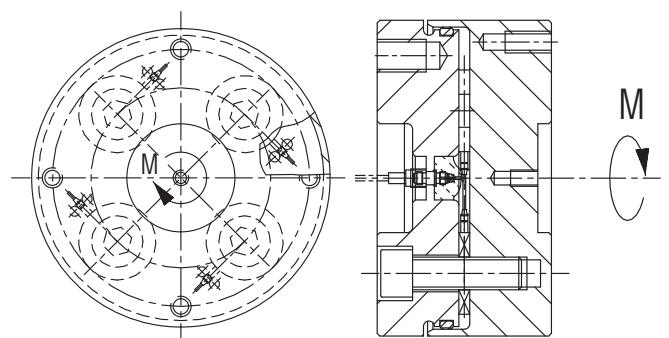
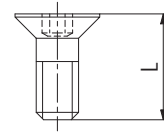
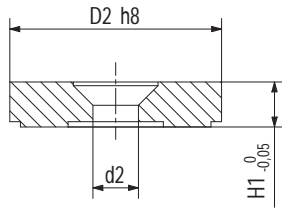

Fig. 6: Torque dynamometer. The resultant torque  $M$  can be calculated by measuring the shear forces  $F_y$ .

9143B\_000-113e-09\_09

**Accessories**

**Preloading Disk**



One countersunk screw is supplied with each preloading disk

Type	For SLS Sensor Type	Thread Size	External Diameter D2	Internal Diameter d2	Disk Thickness H1	Screw Length L
9410A3	9143B...	M3	16,0	3,2	4,25	10,0
9410A4	9144B...	M4	20,0	4,3	4,25	10,0
9410A5	9145B...	M5	24,0	5,3	4,25	10,0
9410A6	9146B...	M6	30,0	6,4	5,5	14,0
9410A7	9147B...	M8	36,0	8,4	7,0	16,0

**Cable/Connector**

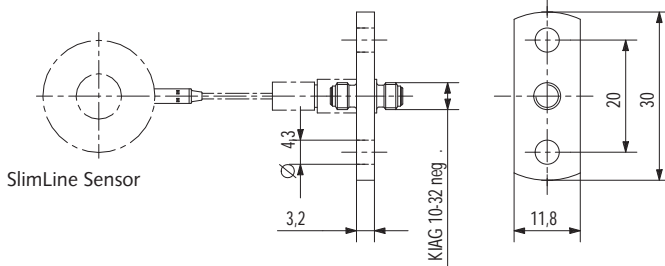

Fig. 7: Coupling Type 1729A1 with steel support; connector KIAG 10-32 neg. on both sides

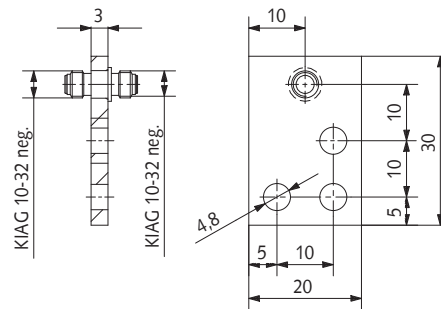

Fig. 8: Coupling Type 1729A2 with plastic support; connector KIAG 10-32 neg. on both sides

**Insulating Foils**

Insulating foils are available for ground-insulated installation. The friction between sensor and base or cover plate is not reduced by this foil, but increased.

For Sensor	Type	9143B...	9144B...	9145B...	9146B...	9147B...
Insulating foil	Art. No.	3.221.284	3.221.285	3.221.286	3.221.287	3.221.487
Ext. ø	mm	16	20	24	30	36
Int. ø	mm	6,1	8,1	10,1	12,1	14,1
Thickness	mm	0,125	0,125	0,125	0,125	0,125

**SLS Assembly**

2, 3 or 4 SlimLine sensors are incorporated in a sealed (IP65) plug connection with an individually selected cable length. Either individual signals or the summation signal (all sensors connected in parallel) appear at the output. See data sheet 9130B\_000-766.

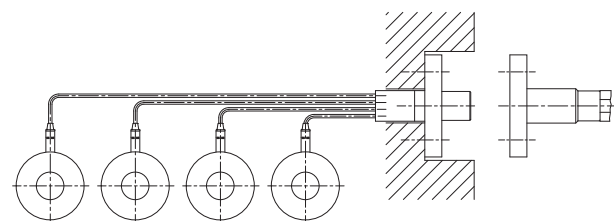

Fig. 9: SLS Assembly

9143B\_000-113e-09-09

## Ordering Key

Type 914  B

### Measuring Range

0 ... ±0,9 kN	3
0 ... ±1,7 kN	4
0 ... ±2,7 kN	5
0 ... ±4,0 kN	6
0 ... ±8,0 kN	7

### Connector

KIAG 10-32 pos. integrated	2
Mini-Coax neg.	3

### Cable Length

Length = 2 m (standard)	1
Length = 0,1 ... 2 m (please indicate)	9

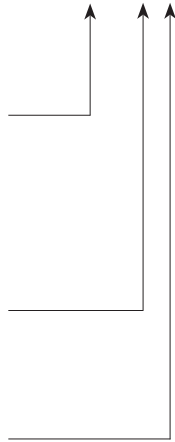

The following connections can be used:

