

SlimLine Quartz Force Links

Measurement of tension and compression forces

Type 9173B, 9174B,
9175B, 9176B

Compact force link for measuring tension and compression forces. A SlimLine sensor (SLS) Type 9133B21 ... 9136B21 is fitted under preload and ground-insulated between two steel parts with threads. The integral cable is additionally protected by a Viton cable covering. Already calibrated (only compression force range), the SLS force links are easy to install and are immediately ready for measurement.

- Calibrated quartz force link
- Compact design, extremely small dimensions
- Integral non-detachable cable with Viton cable covering
- Coupling with mounting plate



Technical data

Sensitivity	pC/N	≈ -3,5
Linearity	% FS0	≤±1
Hysteresis	% FS0	≤1
Response threshold	N	≤0,02

Insulation resistance	Ω	10 ¹³
Ground insulation	MΩ	≥100
Temperature coefficient	%/°C	-0,02
Operating temperature range	°C	-20 ... 80

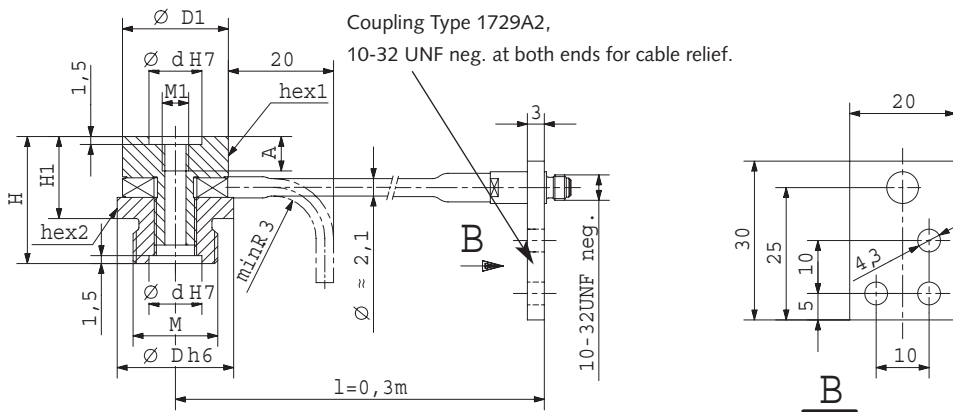

Type	Range: tension (-) and compression (+) kN	Calibrated range kN	Overload kN	Bending moment (max., F _z = 0) Nm	Dimensions in mm										
					D	D1	d	H	H1	A	M	M1	hex1 o.SW	hex2 o.SW	
9173B	-3 ... +12	0 ... 12	-3,3/+17	15	18	16	8	22	14	5,5	M12x1,25	M4	14	16	
9174B	-5 ... +20	0 ... 20	-5/+25	35	22	20	10	24	16	6,5	M16x1,5	M5	18	20	
9175B	-8 ... +30	0 ... 30	-9/+35	62	26	24	12	28	19	7,5	M20x1,5	M6	22	24	
9176B	-16 ... +60	0 ... 60	-18/+70	134	32	30	15	34	23	9,5	M24x2	M8	28	30	

* See data sheet DB06.016 about integrated SlimLine Sensor

Description

The preloaded quartz force link can measure tension and compression forces and produces an electrical charge directly proportional to the force applied. This charge is converted by the charge amplifier into a proportional voltage which can then be further processed as required. The mounting of the SLS sensor is ground-insulated thereby largely preventing problems with ground loops.

Application

As a result of its high rigidity, the compact SLS quartz force link is especially suitable for measuring rapidly changing tension and compression forces. The elastic behavior of the test object is not thereby changed by more than a negligible amount. Quasistatic measurements are possible, i.e. measurements with relatively large time constants. Special information on integrated sensors are given in the sensor data sheet.

Examples of use

- Force measurement in robotic systems
- Monitoring on presses, automatic punching, coining and welding machines.
- Clamping processes, e.g. quartz force link combined with hydraulic cylinder
- Joining technology, e.g. insertion, press fitting of components etc.

Fitting methods

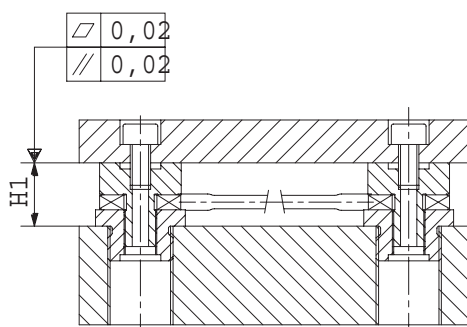

Measurement of tension and compression forces.
Used in combination with hydraulic cylinders, for example.

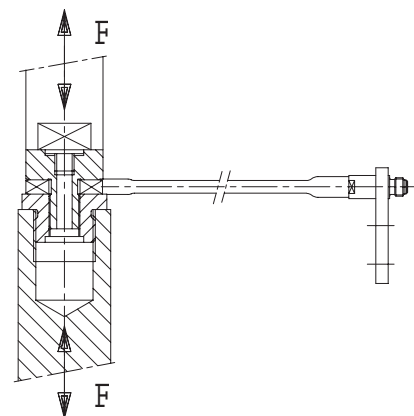

Mounting of SLS quartz force links in force plates or dynamometers with extremely low construction height.

Installation

Before installing the quartz force link, please make sure that the contact surfaces are cleanly machined, flat and rigid. The screw threads of the fastening elements should be perfectly straight in the axial direction. To provide relief from tension force on the integral cable, the coupling Type 1729A2 should always be positioned at a suitable place on the test object.

Accessories

- Force distributing cap Type 9416A3 to A6
- Cable suitable for plug connection 10-32 UNF neg., see data sheet DB15.011.

Scope of delivery

Quartz force link including coupling with mounting bracket Type 1729A2.