

Quartz

Type 9212
9222

High Impedance Load Cells

The 9212 and 9222 are force sensing load cells that measure quasi-static and dynamic events in a wide variety of applications.

Available in two different load cell style housing configurations (hex and square), the 9212 has a 50 pC/lbf sensitivity while the 9222 has 19 pC/lbf.

- High impedance, charge mode
- Rugged quartz force sensing element guarantees long-term stability
- Wide measuring ranges for compression and tension
- Quasi-static response

Description

The 9212 and 9222 quartz load cells provide a choice of sensitivity, threshold and housing configuration while retaining the capability to measure fast dynamic events and perform short-term (quasi-static) measurements. These piezoelectric sensors are capable of measuring compression forces from less than one pound force to 5000 lbf and tension forces to 500 lbf. Minute incremental forces may be measured at any level in these ranges through elimination of static or tare weight component. The load cells feature high rigidity and are capable of withstanding compression overloads of 20%.

The quartz sensing element of the 9212 Load Cell is contained in a low profile housing configured in a 5/8 Hex. The distinguishing feature of this sensor is the 50pC/lbf sensitivity making it ideally suited for low level force measurements. The 9212 is also available in an M1 version which adds an impact cap to the top surface of the cell allowing it to be used for impact-force measurements. The 9222 Quartz Load Cell, differs only in housing configuration, and except for sensitivity it has nearly identical performance specifications. The sensitivity of the 9222 cell is 19pC/lbf making it the first choice for medium to high end force measurements.

Application

These load cells are ideally suited for direct force measurements in process control applications such as press fit assembly, crimping, riveting and impact force testing. They also be used with shakers for modal analysis, in machine tool measurements, or various automotive, aerospace and robotic testing.

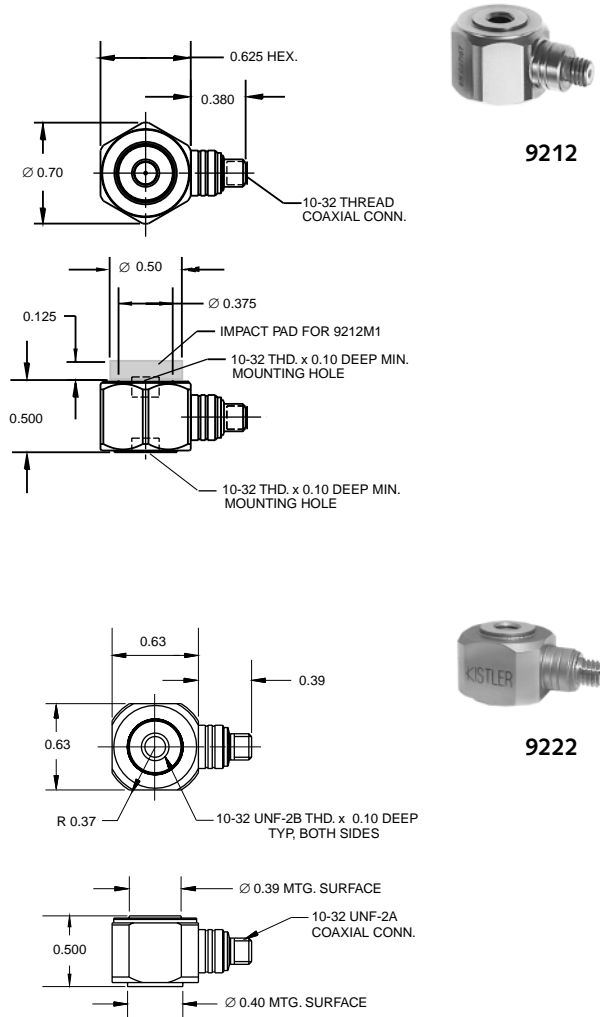

000-418a-06.03 (K6.9212/22)

Technical Data

Type		Units	9212	9222
Range	compression	lbf	5000	5000
	tension	lbf	500	500
Maximum Force	compression	lbf	6000	6000
Threshold		lbf _{rms}	0.001	0.002
Sensitivity nom.		pC/lbf	-50	-19
Non-linearity nom. (max. ±1%)		% FSO	±0.5	±0.5
Rise Time 10 ... 90%		µs	<6	<6
Capacitance		pF	58	23
* Rigidity		lbf/µin	>5	>5
Natural Frequency nom. (no load)		kHz	70	70
Shock Limit (1 ms pulse) max.		g _{pk}	<10000	<10000
Temperature Coefficient of Sensitivity		%/°F	0.01	0.02
Temperature Range Operating		°F	-400 ... 300	-320 ... 300
Insulation Resistance @ room temperature		Ω	10 ¹³	10 ¹³
Construction:				
	Sensing Element	type	quartz	quartz
	Sealing - Housing/Connector	type	welded/epoxy	welded/epoxy
	Connector	type	10-32 neg.	10-32 neg.
	Housing/Base	material	17-4 PH	17-4 PH
	Weight	grams	19	19
	Mounting Torque	lbf-in	18	18

1 g = 9.80665 m/s², 1 inch = 25.4 mm, 1 gram = 0.03527 oz, 1 lbf-in = 0.1129 Nm

Mounting

Reliable and accurate measurements require that the mounting surface be clean and flat. Both models are supplied with two 10-32 mounting studs for attachment to the test structure. When several units are installed between two plates, the mounting surfaces in contact with the cells must be plain-parallel to prevent stresses induced into the individual cells. The Operating Instruction Manual for the 9212 and 9222 provides detailed information regarding mounting surface preparation.

Related Products

9712B... low impedance, voltage mode versions of 9222

Ordering Information

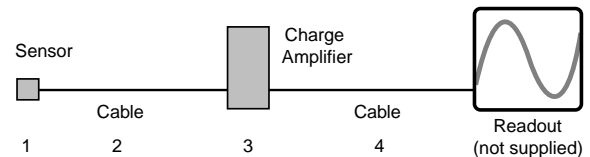

sp = specify cable length in meters

- 1 - 9212 load cell, 50 pC/lbf or
9222 load cell, 19 pC/lbf or
9212M1 load cell with 900A1 impact force cap
- 2 - 1631Asp low noise cable, 10-32 pos. to BNC pos., or
1631Csp premium low noise cable, 10-32 pos. to BNC pos.
- 3 - 5000 series charge amplifier
- 4 - 1511sp output cable, BNC pos. to BNC pos.

Supplied Accessories

- 8402 (2) 10-32 mounting studs with 9212 and 9222

Optional Accessories

- 900A1 impact pad