

Strain Transmitter

Type 9234A...

Highly Sensitive Surface Strain Sensor with Integrated Electronics

The transmitter is suitable for measuring force-proportional strain on machinery or structural surfaces (indirect force measurement).

- Adjustment of the charge amplifier to 0 ... ± 10 V FS by remote control
- Measuring ranges can be switched between 100 % FS and 10 % FS (also under load)
- Very high measuring sensitivity even minute forces can be accurately measured
- Low resistance signal transmission as no highly insulated connecting cable is required
- Extremely simple installation as sensor is secured with only one M6 screw
- Rugged industrial and splash-proof version (IP65)
- Because of its low acceleration sensitivity also suitable for measurements on moving parts
- Ground isolated version available for eliminating noise due to ground loops (Type 9234AxxU41 optional available)

Description

The strain of the base material acts on the two contact surfaces as a change in distance to the sensor. The case behaves as an elastic transmission element and converts the change in distance into a force. The piezoelectric elements in the sensor part subjected to shear strain produce an electric charge Q (pC) proportional to this force. The electronic's integrated in the strain transmitter processes the charge to produce an analog voltage signal of 0 ... ± 10 V FS.

The measuring signal can be further processed as a relative value. For absolute value measurements (e.g. in N or kN), the strain transmitter must be calibrated against an appropriate reference.

The measuring range of the transmitter can be adjusted by remote control. The integrated electronic circuitry also enables the range to be switched between 100 % FS and 10 % FS. The measuring range can be selected in the basic setting or during a measuring cycle.

The industrial grade construction of the transmitter makes it suitable for use in dirty and moisture-laden environments. Low resistance cables simplify signal transmission to the machine control system.



Application

Applications for the strain transmitter include for example:

- Monitoring of all types of machinery in C-frame construction: e.g. presses and automatic assembly machines. Because of its easy installation, the transmitter is ideal for retrofitting on existing machinery.
- Machine safety monitoring, e.g. protecting mechanical presses against overload.
- Quality control on manufacturing plants for joining processes, e.g. in orbital riveting, clinching or resistance spot welding.
- Monitoring machine tools, e.g. prompt detection of tool breakage or tool collision.

Technical Data

Measuring Ranges

Measuring range, nominal (1 $\mu\epsilon$ = 1 microstrain = 10^{-6} m/m)		
Measuring range I	$\mu\epsilon$	FS \pm 600
Measuring range II	$\mu\epsilon$	FS \pm 60
Measuring range for \pm 10 V output voltage adjustable within		
Measuring range I	$\mu\epsilon$	\approx 60 ... 600
Measuring range II	$\mu\epsilon$	\approx 6 ... 60
Measuring range, preset (Type 9234A1...)		
Measuring range I	$\mu\epsilon$	FSP \pm 300
Measuring range II	$\mu\epsilon$	FSP \pm 30
Overload		
Measuring range I/II	$\mu\epsilon$	FS \pm 900
Sensitivity		
Measuring range I	$\mu\epsilon$ /V	\approx 6 ... 60
Measuring range II	$\mu\epsilon$ /V	\approx 0,6 ... 6
Temperature coefficient of sensitivity (5 ... 50 °C)	%/°C	0,07

Adjustment of the Measuring Range

Adjustment steps		
Measuring range I/II	mV	8,5 ... 1 000
Adjustment error (FSA = set, adjustment measuring range)		
Measuring range I/II	\pm % FSA	0,5 ... 5

Supply

Supply voltage	VDC	18 ... 30
Current (no load)	mA	<20

Output

Voltage	V	0 ... \pm 10
Output voltage limitation	V	>10,5
Current	mA	< \pm 1
Resistance	Ω	\approx 10
Zero point error (Reset)	mV	< \pm 15
Noise (0,1 ... 1 MHz)		
Measuring range I	mV _{pp}	<10
Measuring range II	mV _{pp}	<25
Reset-Operate transition		
Measuring range I	mV	< \pm 4
Measuring range II	mV	< \pm 40
Frequency range (-3 dB)	kHz	\approx 0 ... 10
Drift, at 20 °C		
Measuring range I	mV/s	< \pm 0,1
Measuring range II	mV/s	< \pm 1

Control Signals

Select measuring range		
Measuring range I (Pin 2)	V	2,4 ... 30 (or open)
Measuring range II (Pin 2)	V	0 ... 0,8 (or GND)
Delay	ms	<2
Measurement		
active (Operate) (Pin 3)	V	0 ... 0,8 (or GND)
inactive (Reset) (Pin 3)	V	2,4 ... 30 (or open)
Delay (Reset-Operate)	ms	<2

Adjustment Measuring Range (see Page 8)

Pin 4 R_/CS		
Pin 6 R_U/D		
Pin 7 R_/INC		
High level (default) (1)	V	2,4 ... 30
Low level (active) (0)	V	0 ... 0,8
Rise/fall time	μ s	<500
Storage time	ms	>20
Cycle duration	μ s	>100
Operating temperature range	°C	-10 ... 70
Storage temperature range	°C	-20 ... 80

General Technical Data

EMC testing; complies with EU directives		
Emissions	EN61000-6-3/EN61000-6-4	
Interface immunity	EN61000-6-1/EN61000-6-2	
Weight	g	93
Degree of protection (DIN40050)	IP65	
Plug connection*	M12x1 8-pole, screened	

*) Compatible with connectors and cables from the following suppliers: Lumberg, Escha, Binder, Hirschmann, Lemo

Application Examples

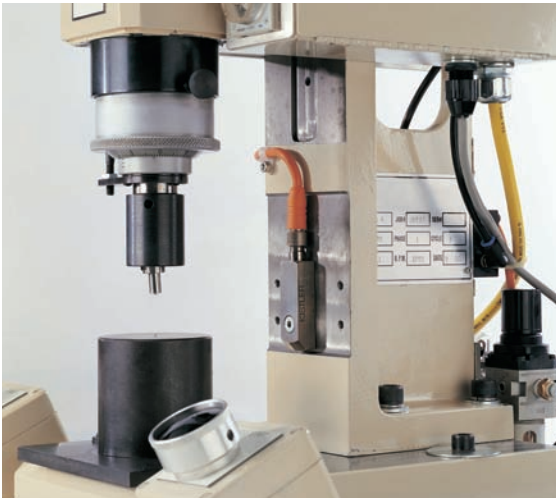

Fig. 1: Measuring force-proportional strain on a wobble riveting machine (C-form construction)



Fig. 2: Monitoring a metal forming press (C-form construction) against overload

Mounting

- Alignment of the transmitter to the machine structure. The measuring axis should be positioned according to the best possible strain curve.
- The cable run close to the transmitter should be as free as possible from pushing or pulling forces. The cable should be clamped in place to avoid strain or vibration transmission.
- Machining the surface at the measuring point and tapping the M6 thread (see Fig. 3).

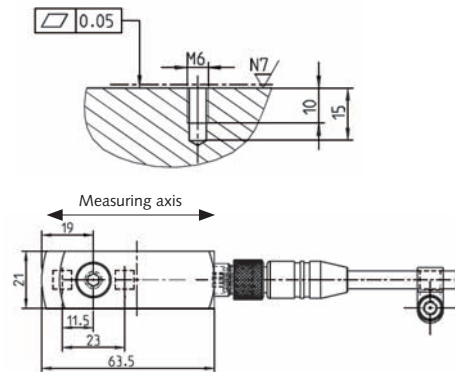

Fig. 3: Preparing the clamping surface

- Screw M6x22 (Art. No. 6.150.101)
Tightening torque: 10 N·m ±0,5 N·m
- Cable clip (Art. No. 5.210.375)
Screw (Art. No. 6.120.021)
Washer (Art. No. 6.220.022)

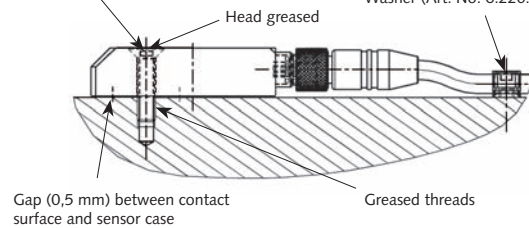

Fig. 4: Mounting by means of a countersunk screw

9234A_000-447e-04.07

Adjusting the Measuring Range

The optimum measuring range of the transmitter can be selected by actuating the integrated electronic system. Adjustment is made with a service unit or directly with the machine control system SPC (see Fig. 5).

The entire range of measuring range I: $\pm 600 \mu\epsilon \approx 10 \text{ V}$ and measuring range II: $\pm 60 \mu\epsilon \approx 10 \text{ V}$ can be adjusted to a particular value or signal curve in 100 steps (0 to 99) with an electronic potentiometer. The relationship between the step number (step xx) and the associated measuring range ($\mu\epsilon$) is illustrated in the following graph. When the transmitter is adjusted to the measuring range required, the setting is saved in the integrated charge amplifier electronic system.

Relationship Between Step Number (Step, Level Set) and Measuring Range

Measuring Range [$\pm\mu\epsilon$]		Step Number	
Range I	Range II	Step	Tolerance
600	60	2	+2/-1
550	55	3	± 2
500	50	4	± 2
450	45	6	± 2
400	40	8	± 3
350	35	11	± 3
FSP: 300	30	14	± 4
250	25	19	± 5
200	20	25	± 6
150	15	37	± 8
100	10	60	± 10
60	6	99	+0/-10

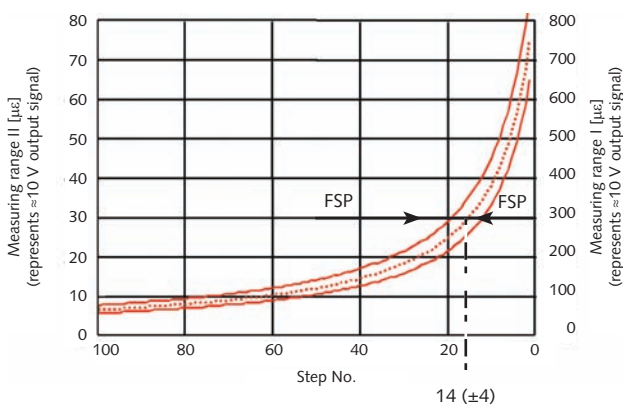

Fig. 5: Distance between measuring range and adjustment step number full scale signal $\approx 10 \text{ V FS}$

Accuracy of the Adjustment

		Measuring Range I	Measuring Range II
Adjustment step	mV	8,5 ... 1 000	8,5 ... 1 000
	$\mu\epsilon$	0,6 ... 60	0,06 ... 6
Adjustment step	% FS, FSP, FSA	0,5 ... 5	0,5 ... 5

The Preset Measuring Range (FSP)

The strain transmitters of the type series 9234A1... are preset to a value of measuring range I: $\pm 300 \mu\epsilon \approx 10 \text{ V}$ and measuring range: $\pm 30 \mu\epsilon \approx 10 \text{ V}$. The adjustment is made at the Kistler factory during production. The measuring ranges set can be checked using a mechanical input signal (strain signal).

Setting any Measuring Range (FSA)

To change this setting, the relevant signals must be actuated at pin positions 4, 6 and 7. The adjustment of the measuring range can be carried out in 2 ways:

1. Setting the Measuring Range where the Setting of the Electronic Potentiometer is Known

The measuring range can be set by matching or adjusting the step position (higher or lower). If the step number and thus the measuring range set is known, the newly set measuring range (FSA) can be determined as an approximate value from the table on Page 4 or Fig. 5.

Example

Value previously set:

Measuring range I (FSP) = $300 \mu\epsilon \approx 10 \text{ V} \approx \text{Step } 14 (\pm 4)$

Correction by +11 steps

New value set:

Measuring range I (FSA) = $200 \mu\epsilon \approx 10 \text{ V} \approx \text{Step } 25$

2. Setting the Measuring Range where the Setting of the Electronic Potentiometer is not Known

If one wants to reset an accurate step position or measuring range ($\mu\epsilon$), the step number must first be set to "Step 0" (largest measuring range, sensor at its least sensitive). The measuring range wanted can now be set and stored starting from the new basis (Step 0).

The storage process saves the set position of the electronic potentiometer. The step number or set measuring range must – if so desired – be documented by the user.

Definition of the Measuring Range

Measured Value		Measuring Range I	Measuring Range II
FS	Maximum measuring range	$\pm 600 \mu\epsilon \approx 10 \text{ V}$	$\pm 60 \mu\epsilon \approx 10 \text{ V}$
FSP	Preset measuring range, Type series 9234A1...	$\pm 300 \mu\epsilon \approx 10 \text{ V}$	$\pm 30 \mu\epsilon \approx 10 \text{ V}$
FSA	Measuring ranges set to a specific value	$\pm 0 \dots 600 \mu\epsilon \approx 10 \text{ V}$	$\pm 0 \dots 60 \mu\epsilon \approx 10 \text{ V}$

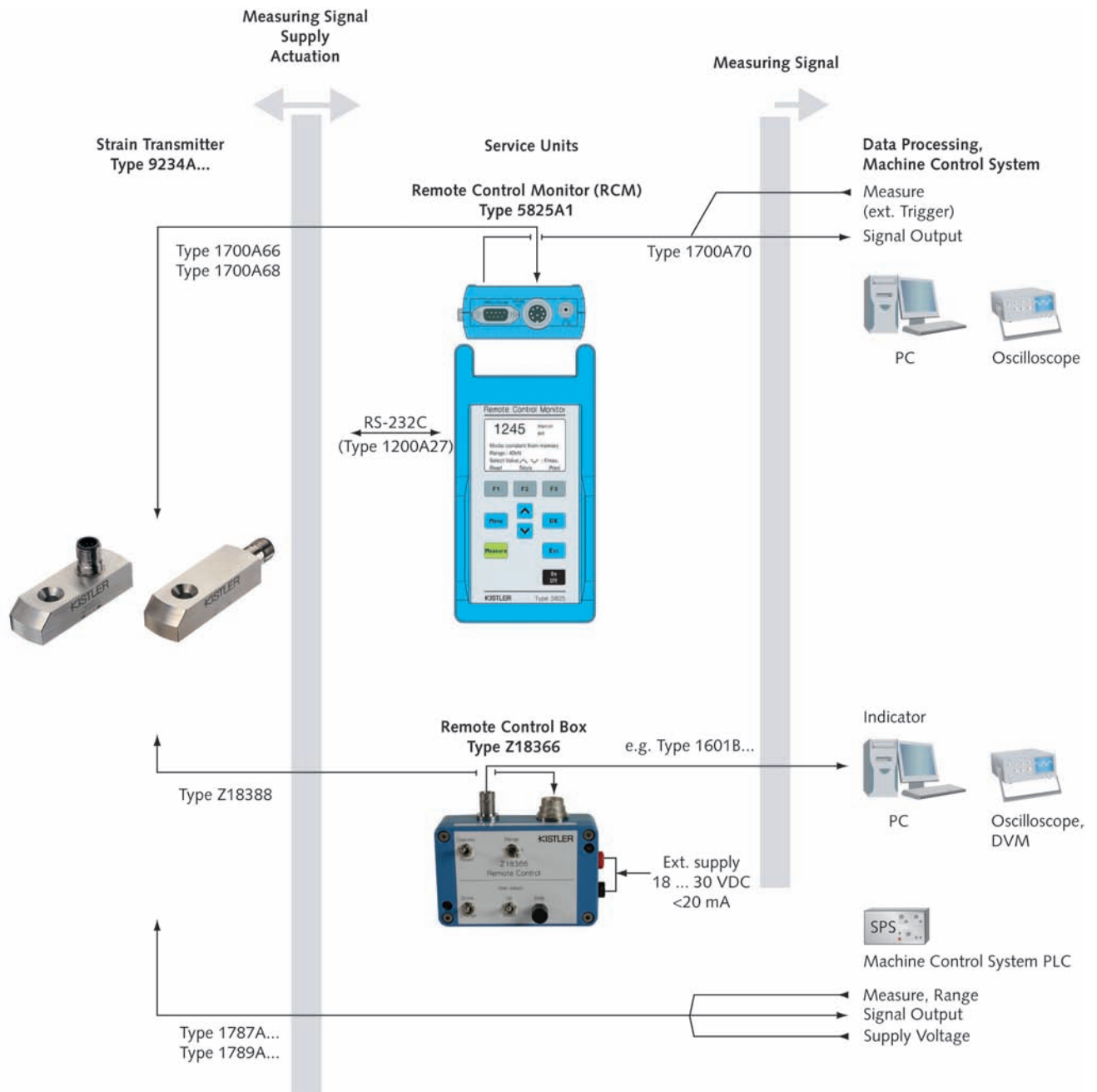

9234A_000-447e-04.07

Fig. 6: Variations of actuation and measured data acquisition

Dimensions

Strain Transmitter with Connecting Cable Type 1787A...

Gap of 0,5 mm between surface and sensor case

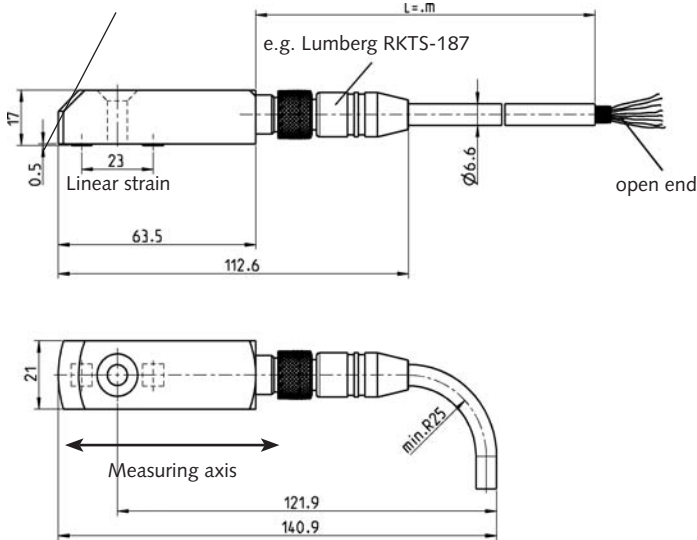

Fig. 8: Strain transmitter Type 9234Ax0

Strain Transmitter with Connecting Cable Type 1789A...

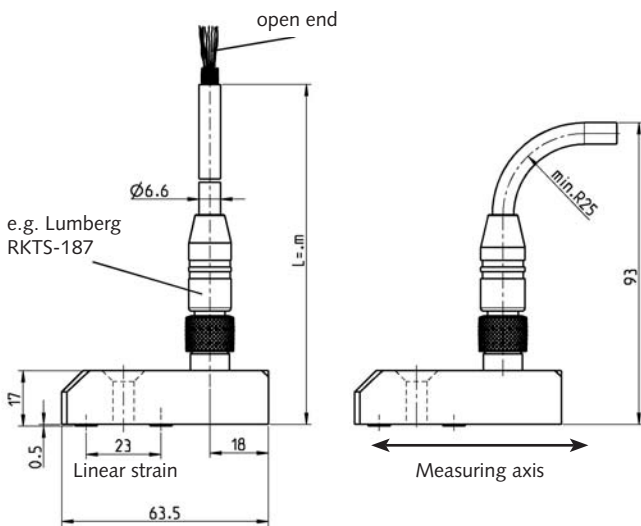
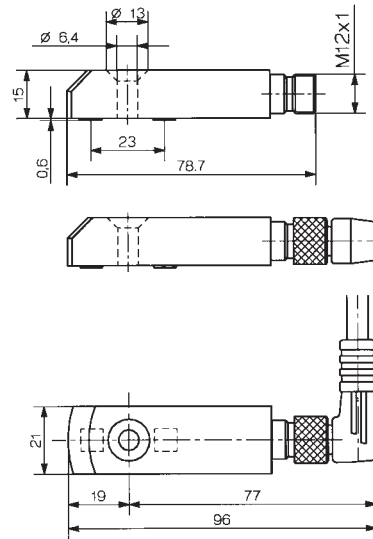
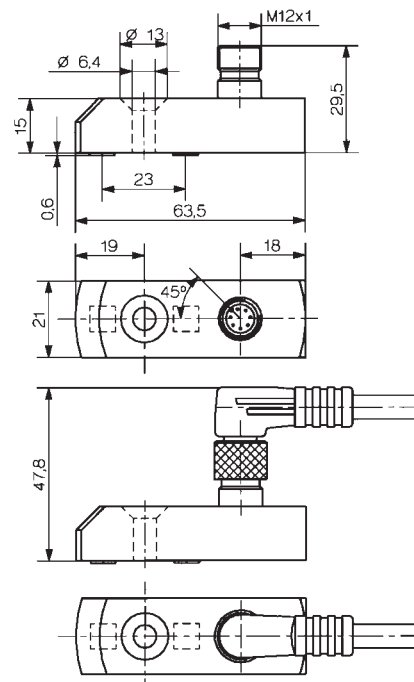

Fig. 9: Strain transmitter Type 9234Ax1



9234A_000-447e-04.07

Schematic Diagram

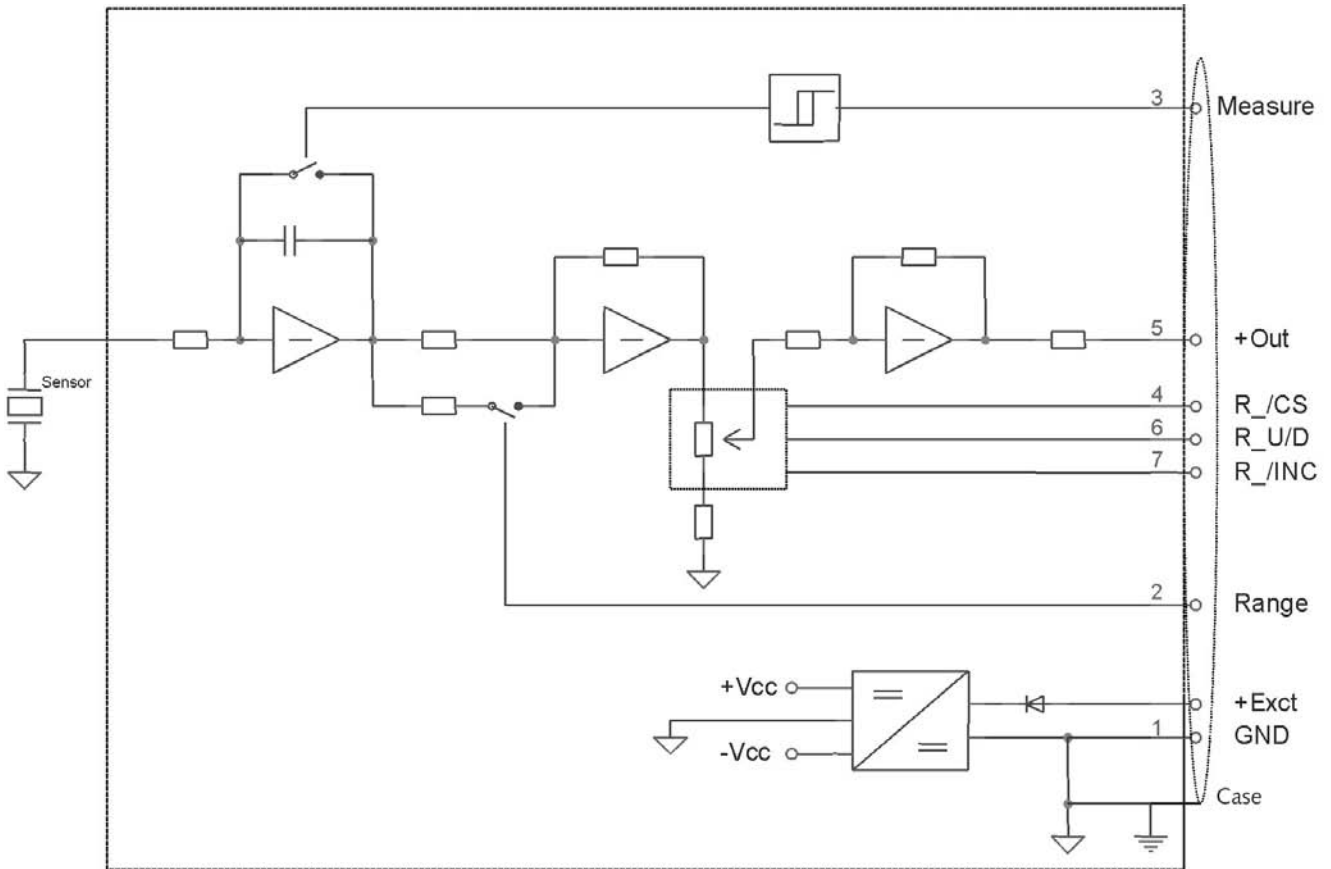

Fig. 10: Schematic diagram strain transmitter Type 9234A...

Output Connector Detail Strain Transmitter

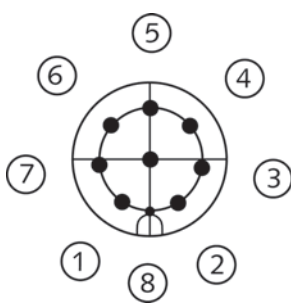

Fig. 10: Pin allocation (View A)

Colors of Individual Cables Type 1787A... and Type 1789A... are Finished with 8-pole LUMBERG Connector

1	GND	white
2	Range	brown
3	Measure	green
4	R_/CS	yellow
5	Signal Out	gray
6	R_U/D	pink
7	R_/INC	blue
8	Exct	red

9234A_000-447e-04.07

Actuation of the Electronic Potentiometer

The electronic potentiometer (E-Poti) is adjusted via the connections R_/CS, R_U/D and R_/INC (pin positions 4, 6 and 7).

The E-Poti is selected (unlocked) with the signal R_/CS "low" to allow adjustment with R_U/D and R_/INC. A trailing edge with signal R_/INC (high too low) changes the value (positive or negative depending on the condition of the R_U/D signal, see truth table).

The newly set value is saved with a leading edge (low too high) of the R_/CS signal if the R_/INC signal is "high".

The following truth table defines the conditions required to adjust the potentiometer:

R_/CS	R_U/D	R_/INC	Gain
1	x	x	Measuring range constant, value saved (locked)
0	1	$\overline{1}$	Increase value by one step (UP)
0	0	$\overline{1}$	Reduce value by one step (DOWN)
$\overline{1}$	x	1	Save existing value

The time sequences must be taken from the following graph and table:

AC Voltage Signals, Timing Diagram

Symbol	Parameter	Limits		Unit
		Min.	Max.	
t_{CI}	\overline{CS} to \overline{INC} setup	1		μs
t_{ID}	\overline{INC} HIGH to U/ \overline{D} change	1		μs
t_{DI}	U/ \overline{D} to \overline{INC} setup	10		μs
t_{IL}	\overline{INC} LOW period	10		μs
t_{IH}	\overline{INC} HIGH period	10		μs
t_{IC}	\overline{INC} inactive to \overline{CS} inactive	10		μs
t_{CPH}	\overline{CS} deselect time (STORE)	20		ms
t_{CPH}	\overline{CS} deselect time (NO STORE)	100		μs
t_{IW}	\overline{INC} to Poti value change		1	ms
t_{CYC}	\overline{INC} cycle time	100		μs
$t_{R}, t_{F}^{(7)}$	\overline{INC} input rise and fall time		500	μs
$t_{PU}^{(7)}$	Power up to Poti value stable		10	ms

AC Control Signals

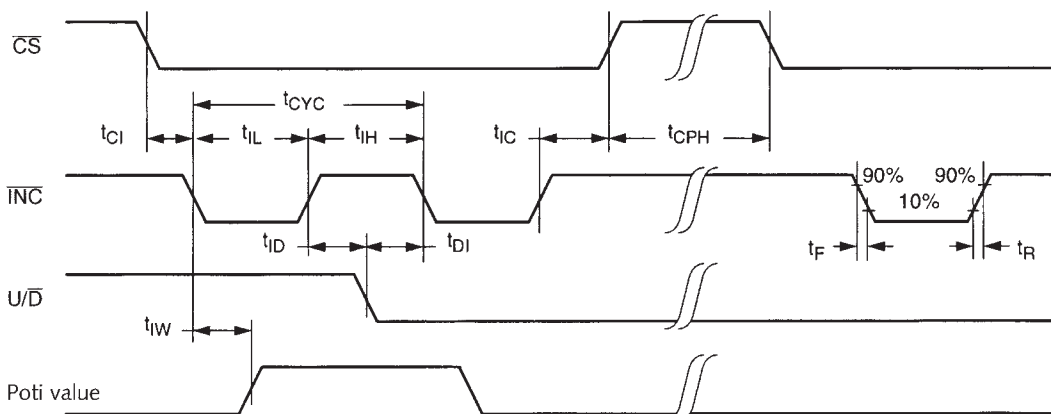

Fig. 11: AC control signals

9234A_000-447e-04.07

Accessories Included for Type 9234A...

• Protective connector cover	Art. No. 5.211.409
For installing the transmitter	
• Countersunk screw M6x22 (Screw quality 10.9)	6.150.101
For securing the connecting cable	
• Cable clamp	5.210.375
• Fixing screw M5x10	6.120.021
• Flat washer	6.220.022

Accessories Included for Type 9234AU41

• Cheese-head screw M6x30 with hexagon slot	Art. No. 6.120.033
• Washer M6 DIN 125A	6.220.006
• Ceramic ring D13/6,4x1,2	3.221.402
• Preloading disk D12/6,5x4	3.211.556
• Isolating sleeve D6,4/6x18,5	3.221.401

Optional Accessories

	Type
Cable connection (screened) to machine control:	
• Connecting cable M12-8-pole connector socket – straight, open cable end, cable length 5 m	1787A5
• Connecting cable M12-8-pole connector socket – straight, open cable end, cable length 20 m	1787A20
• Connecting cable M12-8-pole connector socket – right-angled, open cable end, cable length 5 m	1789A5

Cable connection (screened) to Remote Control Monitor
Type 5825A...

• Connecting cable M12-8-pole connector socket – straight, 8-pin plug DIN 45326 Type 1500A57, cable length 2 m	1700A66
• Connecting cable M12-8-pole connector socket – right-angled, 8-pin plug DIN 45326 Type 1500A57, cable length 2 m	1700A68
• Connecting cable for Remote Control Monitor Type Z18366	Z18388

**Service Equipment for Adjusting the Measuring Range and
Carrying out the Initial Measurements:**

- Remote Control Box Type Z18366 (see Fig. 13)
- Remote Control Monitor Type 5825A1 (see Fig. 14)

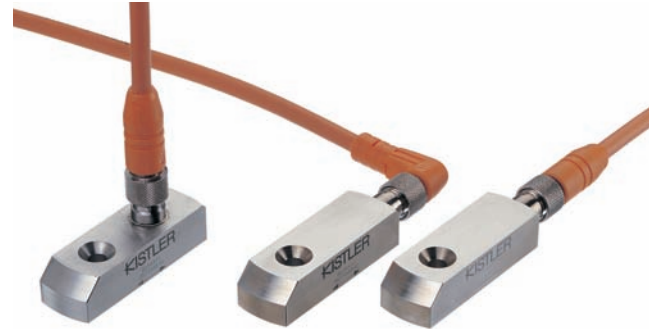

Fig. 12: Optional plug positions and connecting cable

Remote Control Box Type Z18366

Service unit for transmitter adjustment on site

- Transmitter actuation (Reset-Operate, setting functions for
measuring range adjustment, switching between Measuring
Ranges I and II)
- Measuring signal analog output
- External power supply required (18 ... 30 VDC, 20 mA)



Fig. 13: Remote Control Box Type Z18366

Remote Control Monitor (RCM) Type 5825A1

Battery-operated service unit for transmitter adjustment on site

- Transmitter actuation (power supply, measuring mode, setting functions for measuring range adjustment, switching between Measuring Ranges I and II)
- Display, indication of set and measured data
- RS-232C, record of the transmitter settings
- External trigger connection
- Analog outputs for trigger and measuring signals
- Power pack for external power supply



Fig. 14: Remote Control Monitor (RCM) Type 5825A1

Ordering Key

Type 9234A

Measuring Range

Preset to measuring range FSP of $\pm 300 \mu\epsilon \approx \pm 10 \text{ V}$	1
Adjusted to special measuring range FSA according to customer specification (on request)	9

Connector Position

Straight, in the direction of the measuring axis	0
At right angles to the measuring axis (90 °), directed upwards	1

Options

Ground-isolated version **Type 9234A** **U41**
(only for Types 9234A10 and 9234A11)