

# Quartz Transverse Measuring Pin

## for Indirect Force Measurement in Machines and Tools

Type 9241CA3, 9241CAsp,  
9241CBsp

Piezoelectric sensor for indirect force measurement in machine structures, tools, etc. in industrial monitoring tasks.

- Preloading allows measuring compression and tension forces
- Can be fixed in any direction and depth in the mounting bore
- Ground-isolated

### Description

The front part of the sensor is sensitive to transversal forces. Shaped as a cylindrical pin, all it needs for its installation is a 10 mm borehole. An integrated clamping system is used to preload the sensor in the borehole enabling it to detect tensile and compressive forces in the machine structure. The ceramic-coated body sleeve allows to mount the sensor ground insulated.

### Application

The sensor is easily mountable and allows to measure forces within a machine part or a tool.

Once installed, the sensor can be calibrated by comparative measurement, e.g. with a calibrating force sensor.

The main application field is the industrial monitoring of machine forces (machine monitoring, tool monitoring, etc.).

In combination with a ControlMonitor (CoMo®) it can be used to monitor limit values of forces that are decisive in the safety and reliability of machines and tools.

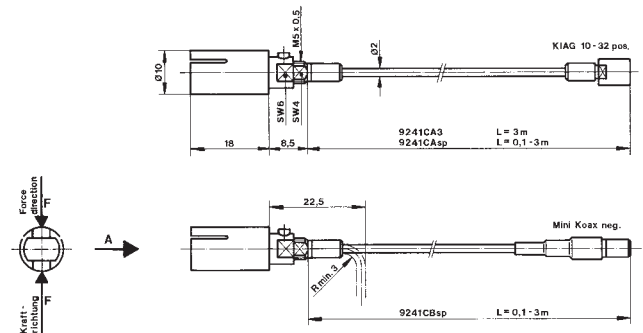

### Technical Data

Range			
with preload 750 N	$\mu\epsilon$		0 ... 500
with preload 1 250 N	$\mu\epsilon$		-150 ... 350
with preload 1 750 N	$\mu\epsilon$		-300 ... 200
Overload			
with preload 750 N	$\mu\epsilon$		850
with preload 1 250 N	$\mu\epsilon$		700
with preload 1 750 N	$\mu\epsilon$		550
Threshold in test object	$\mu\epsilon$		0,005
Sensitivity in test object	$\rho C/\mu\epsilon$		$\approx -15$
Force sensitivity for preload	$\rho C/N$		$\approx -4$
Linearity	% FSO		$\leq \pm 1$
Hysteresis	% FSO		$\leq 1,5$
Repeatability of sensitivity after demounting and remounting	%		$\pm 2$
Acceleration sensitivity (measuring direction)	$\mu\epsilon/g$		$\leq 0,1$
Operating temperature range	$^{\circ}C$		-40 ... 200
Insulation resistance at 20 $^{\circ}C$	$\Omega$		$\geq 10^{13}$
Ground insulation	$\Omega$		$\geq 10^8$
Capacitance	pF		322
Protection class			IP 64
Weight	g		38

1  $\mu\epsilon$  = 1 microstrain =  $10^{-6}$  m/m;  
1 N (Newton) =  $1 \text{ kg}\cdot\text{m}\cdot\text{s}^{-2}$  = 0,1019... kp = 0,2248... lbf,  
1 kp = 1 kgf = 9,80665 N

**Mounting**

By adjusting the nut the sensor is preloaded using a charge amplifier and a display unit.

The mounting tool Type 1393B... is used for deep hole mounting.

**Mounting Examples**

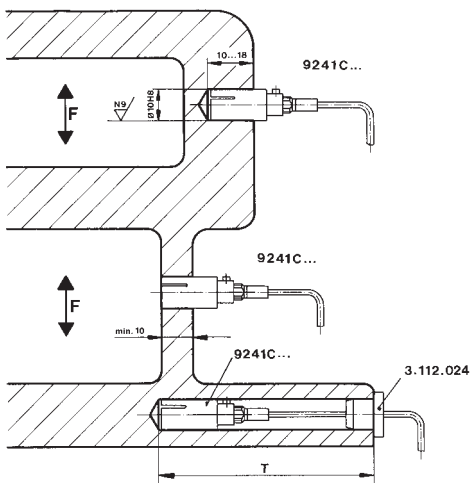

Fig. 1: T = 10 ... 118 mm mounting tool with Type 1393B  
T = 10 ... 318 mm mounting tool with Type 1393Bsp100-300

**Transition Coupling for Type 9241CA...**

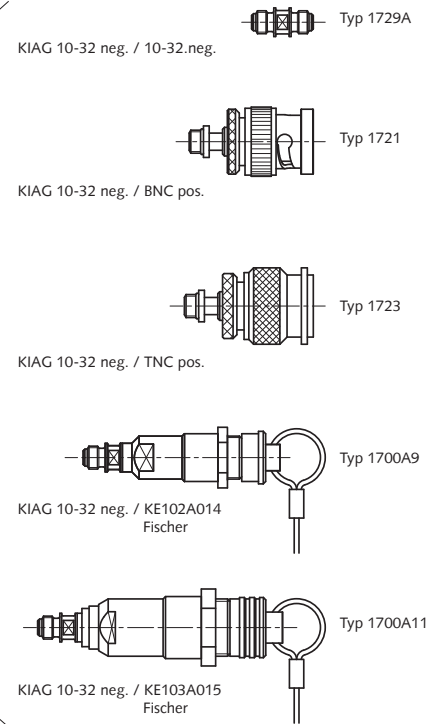

Fig. 2: Transition coupling

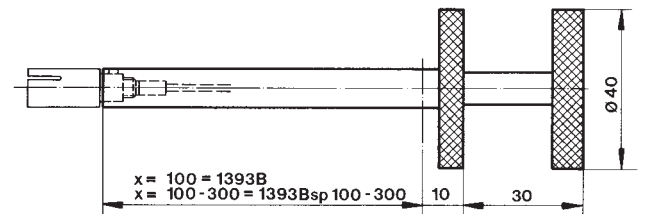
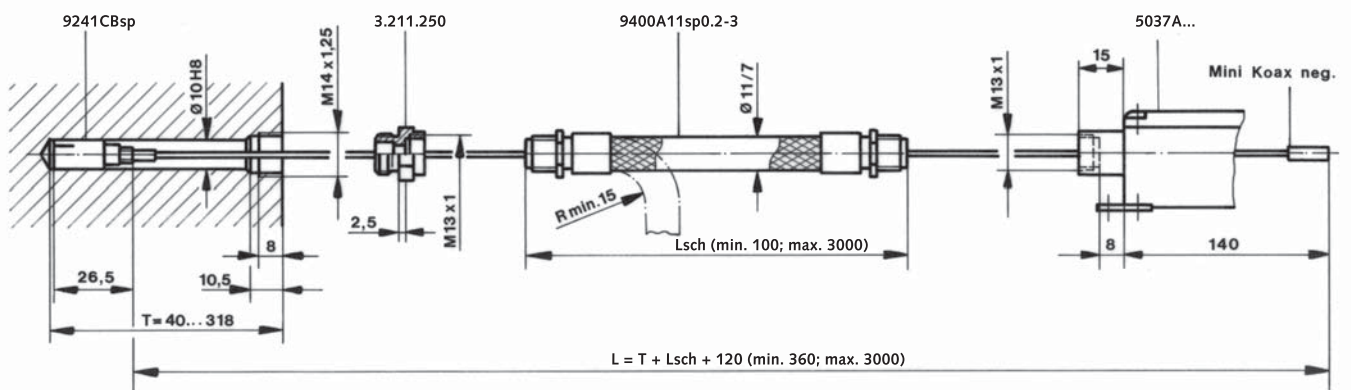

Fig. 3: Mounting tool

**Industrial Application Type 9241CBsp**

Protection hose Type 9400A11sp0,2-3  
Industrie charge amplifier Type 5037B...



9241\_000-140e-05.09

**Examples with Common Protection Hoses**

**Variant I**

Plastic protection hose and fast screwing by FESTO Pneumatic

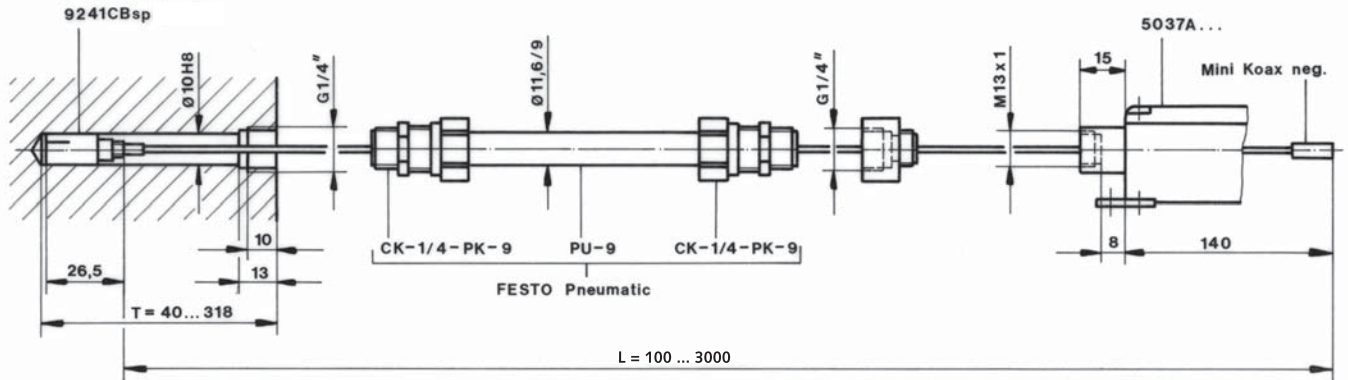

**Variant II**

Flexopneu hose with metal braiding and fast screwing by FESTO Pneumatic

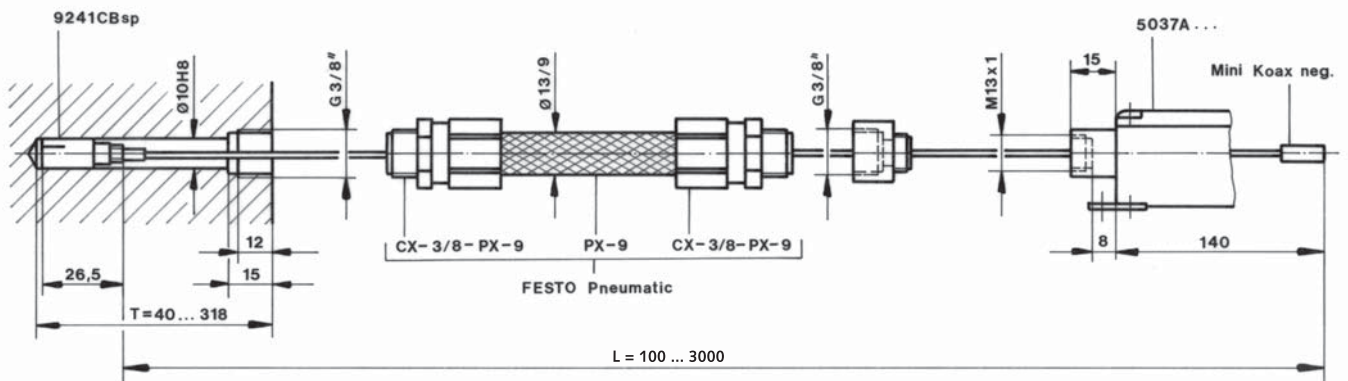

**Accessories**

- Mounting tool
- Protection hose
- Connecting cable

**Type/Art. No.**

1393B  
1393Bsp100-300  
9400A11sp,0,2-3  
1937A1

**Ordering Key**

Sensor with integrated high temperature cable, KIAG 10-32 pos. connector (l = 3 m)	3
Sensor with integrated high temperature cable, KIAG 10-32 pos. connector (l = 3 m)	sp
Please specify length at order (l <sub>min</sub> = 0,1 m, l <sub>max</sub> = 3 m)	

Type 9241CA

Type 9241CB

Sensor with integrated high temperature cable, mini coax. neg. connector	sp
Please specify length at order (l <sub>min</sub> = 0,1 m, l <sub>max</sub> = 3 m)	

9241\_000-140e-05.09