

Torque Measuring Flange

Type 4504A...

Digital Telemetry Based, Short-Design, Robust, High Accuracy

Type 4504A... torque measuring flanges operate on the strain gage principle. The integral, digital measurement preconditioning system produces analog or digital output signals, which are transmitted without contact. The rotor runs in the stator ring without mechanical bearings and is therefore free from wear.

- Digital telemetry non-contact signal transmission
- Rated torque: 200 ... 10,000 Nm (1,770 ... 88,510 lbf-in)
- Speed ranges up to 15,000 rpm
- Accuracy class: 0.1%, 0.05% optional
- Very short axial dimensions
- Compact flange-to-flange solution
- Strain gage measuring system
- Very high accuracy
- Maintenance-free, bearingless
- Electronic control of sensor
- Magnetic speed measurement

Description

Type 4504A... torque measuring flange was designed to be a very short flange-to-flange solution and its rotor can be installed from one side (normally the test specimen side), straight to the flange of the loading machine. This allows easy, cost-effective assembly into a power train.

Options

- Frequency output
- Speed measurement 720 pulses/rev. (Track A and B)
- Rotational angle measurement, resolution: 0.025° (Track A and B)
- Separate output signal to connectors C and D
- Calibrated RS-232C output

Application

The extremely narrow profile of the Type 4504A... torque measuring flange makes it very suitable for many test rig applications: Test bed for engines, dynamometer, wheel load simulation, gear boxes, pumps, electric motors and many others.



Technical Data

Type 4504A...			...200...	...500...	...1K...	...2K...	...3K...	...5K...	...10K...
Nominal torque	M _{nom}	Nm (lbf-in)	200 (1770)	500 (4426)	1000 (8851)	2000 (17702)	3000 (26553)	5000 (44255)	10000 (88510)
Operating torque	M _{op}	Nm (lbf-in)	400 (3540)	1000 (8851)	2000 (17702)	4000 (35404)	6000 (53106)	10000 (88510)	20000 (177020)
Rupture torque	M _{rupt}	Nm (lbf-in)	800 (7081)	2000 (17702)	4000 (35404)	8000 (70808)	12000 (106212)	20000 (177020)	40000 (354040)
Max. dynamical torque	M _{dyn}	Nm (lbf-in)	200 (1770)	500 (4426)	1000 (8851)	2000 (17702)	3000 (26553)	5000 (44255)	10000 (88510)
Max. speed (with Q = 6.3)	n _{nom}	rpm	15000	12000	12000	10000	10000	8000	8000
Torsional rigidity	C _T	kN·m/rad (klbf-in/rad)	395 (3496)	1400 (12391)	2560 (22659)	7100 (62842)	10000 (88510)	15000 (132765)	37300 (330142)
Rotation angle at M _{nom}	φ	°	0.029	0.02	0.023	0.016	0.017	0.019	0.015
Max. bending moment	M _B	Nm (lbf-in)	140 (1239)	500 (4426)	500 (4426)	1000 (8851)	1600 (14162)	2500 (22128)	4000 (35404)
Max. axial force	F _A	kN (klbf)	4 (0.9)	7 (1.6)	7 (1.6)	12 (2.7)	14 (3.2)	22 (5)	31 (7)
Max. radial force	F _Q	kN (klbf)	3 (0.7)	6 (1.4)	8 (1.8)	15 (3.4)	18 (4.1)	30 (6.8)	40 (9)
Rotor weight	m _{rotor}	kg (lbs)	1.4 (3.1)	3 (6.6)	3.11 (6.9)	4.7 (10.4)	6.6 (14.6)	11.3 (24.9)	13.1 (28.9)
Stator weight	m _{stator}	kg (lbs)	1.6 (3.5)	2.1 (4.6)	2.11 (4.7)	2.5 (5.5)	2.5 (5.5)	4.38 (9.7)	4.38 (9.7)
Moment of inertia (rotor)	j _{rotor}	kg·m ² ·10 ⁻³ (lb·ft ² ·10 ⁻³)	3.3 (78.1)	11.5 (272.2)	11.64 (275.5)	28.2 (667.5)	38 (899.5)	99.28 (2350)	117 (2769.4)
Partial mass of the rotor (measurement side) also for option N1, N2	m _{rotor-M}	kg (lbs)	0.4 (0.9)	1 (2.2)	1.1 (2.4)	2.2 (4.9)	2.8 (6.2)	4.9 (10.8)	5.7 (12.6)
Partial moment of inertia of the rotor (measurement side) also for option N1, N2	j _{N1-M}	kg·m ² ·10 ⁻³ (lb·ft ² ·10 ⁻³)	0.95 (22.5)	3.8 (89.9)	4 (94.7)	13.1 (310.1)	16.8 (397.7)	38.02 (899.9)	52.5 (1242.7)
Balancing class	Q		6.3						
Housing			Hard anodized aluminum						
Protection class			IP54						

General electrical specifications

Output signal (M _{nom})	VDC	±10 (and others as an option)
Supply voltage	VDC	11 ... 30
Power consumption	W	≈4
Load resistance	kΩ	>10
Limit frequency –3 dB	kHz	1
100 % control input	VDC	"On" 3.5 ... 30 "Off" 0 ... 2
Electrical connection		12/8/7 pin built-in plug

Electrical measuring data

Accuracy class	% FSO	0.1/opt. C1: 0.05
Linearity	% FSO	0.1/opt. C1: 0.05
Hysteresis	% FSO	0.1/opt. C1: 0.05
Linearity error including hysteresis	% FSO	0.1/opt. C1: 0.05
Tk0	% FSO/°C (°F)	0.005 (0.009)
Tkc	% FSO/°C (°F)	0.005 (0.009)

Max. deviation with bending moment	% FSO/Nm (lbf-in)	0.002 (0.02)
Max. deviation with axial force	% FSO	0.000145
Max. deviation with radial force	% FSO	0.000125
NP stability (for 24 h)	% FSO	0.03
Reference temperature	°C (°F)	22 (72) ±2
Rated temperature range	°C (°F)	+10 ... +60 (50 ... 140)
Operating temperature range	°C (°F)	0 ... +70 (32 ... 158)
Storage temperature range	°C (°F)	-25 ... +80 (-13 ... 176)

Speed measurement

Speed measurement standard		
Pulse number (Track A)		1 x 60
Max. distance from rotor to probe	mm (in.)	2.5 (0.1)
Speed measurement option N2		
Pulse number (Track A and B):		
- Factory setting		2 x 720
Max. distance from rotor to probe	mm (in.)	1 (0.04)
(adjustable)		

Dimensions

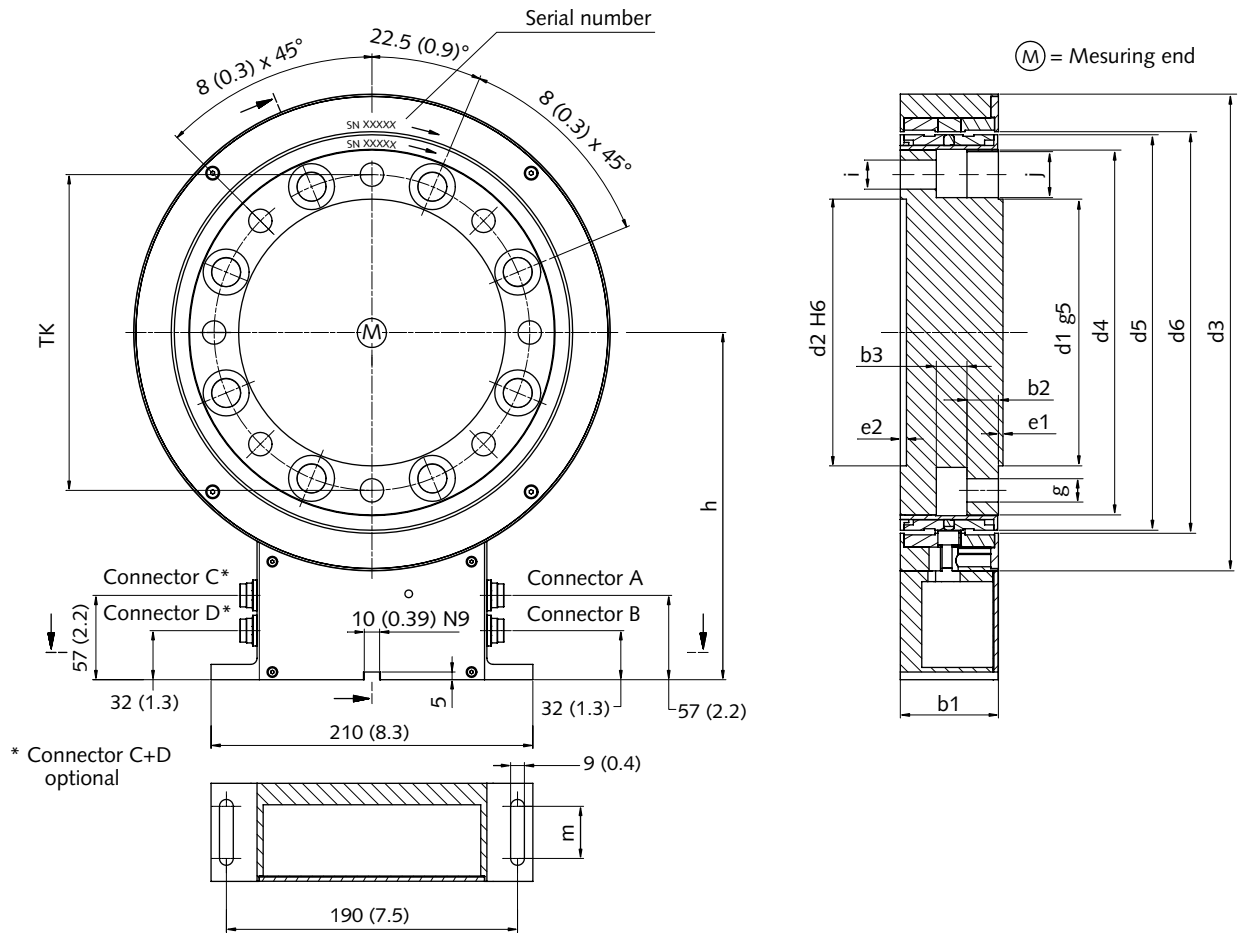

Dimensions in mm (inches)

Size	Range N·m (lbf·in)	b1	b2	b3	e1	e2	Ød1 g5	Ød2 H6	Ød3	Ød4	Ød5	Ød6	TKØ	g	h	Ø i	Ø j	m
2	200 (1770)	30.5 (1.2)	8.5 (0.3)	30.5 (1.2)	3 (0.1)	2.5 (0.1)	90 (3.5)	90 (3.5)	192 (7.5)	120 (4.7)	140 (5.5)	144 (5.6)	105 (4.1)	M8	167.5 (6.5)	8.4 (0.3)	14 (0.5)	17 (0.7)
3	500 (4426)	40.5 (1.6)	13 (0.5)	40.5 (1.6)	3 (0.1)	3 (0.1)	110 (4.3)	110 (4.3)	228 (8.9)	155 (6)	175 (6.8)	179 (7)	133 (5.2)	M12	185.5 (7.2)	13 (0.5)	20 (0.8)	17 (0.7)
3	1000 (8851)	40.5 (1.6)	13 (0.5)	40.5 (1.6)	3 (0.1)	3 (0.1)	110 (4.3)	110 (4.3)	228 (8.9)	155 (6)	175 (6.8)	179 (7)	133 (5.2)	M12	185.5 (7.2)	13 (0.5)	20 (0.8)	17 (0.7)
4	2000 (17702)	42.5 (1.7)	16 (0.6)	42.5 (1.7)	3 (0.1)	4 (0.2)	140 (5.5)	140 (5.5)	263 (10.3)	190 (7.4)	210 (8.2)	214 (8.3)	165 (6.4)	M14	202.5 (7.9)	15 (0.6)	22 (0.9)	17 (0.7)
4	3000 (26553)	42.5 (1.7)	22 (0.9)	55 (2.1)	3 (0.1)	4 (0.2)	140 (5.5)	140 (5.5)	228 (8.9)	190 (7.4)	210 (8.2)	214 (8.3)	165 (6.4)	M14	202.5 (7.9)	15 (0.6)	22 (0.9)	17 (0.7)
5	5000 (44255)	64 (2.5)	21 (0.8)	64 (2.5)	3 (0.1)	4 (0.2)	174 (6.8)	174 (6.8)	311 (12.1)	238 (9.3)	258 (10.1)	262 (10.2)	206 (8)	M18	226.5 (8.8)	19 (0.7)	30 (1.2)	34 (1.3)
5	10000 (88510)	64 (2.5)	23.5 (0.9)	69 (2.7)	3 (0.1)	4 (0.2)	174 (6.8)	174 (6.8)	311 (12.1)	238 (9.3)	255 (9.9)	259 (10.1)	206 (8)	M18	226.5 (8.8)	19 (0.7)	30 (1.2)	34 (1.3)

4504A_000-598a-11.06

Electrical Connections

Pin allocation of the 12 pin built-in standard connector A

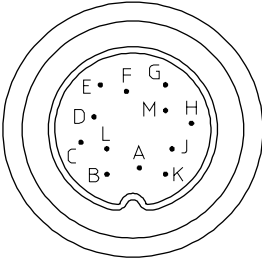
	Function	PIN	Description
	Supply	F A	+U _B Ground relating to +U _B
	Shield	M	In the sensor on housing
	Torque output	C	U _A ±10 VDC at ±M _{Nominal} at >2 kΩ +10 VDC at FS test signal activation R _{i,C} = 10 Ω, output short circuit proof relating to AGND
		D	AGND Ground relating to U _A
	Speed pulses	H	Track A Open collector output, Internal 1 kΩ resistance after +5 VDC (pull up), TTL-level
		G	Track B
		J	Track B with option N2 only not connected
	100% FS test	K	Control Off: 0 ... 2 VDC On: 3.5 ... 30 VDC R _{i,K} = 10 kΩ
	RS-232C connection	B	TXD Digital send path
		L	RXD Digital receive path
	Digital mass potential	E	DGND Ground relating to speed pulses, calibration/control input, RS-232C connection

Pin allocation of the 7 pin built-in standard connector B

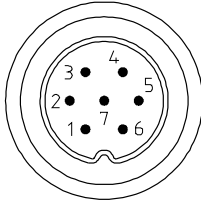
	Function	PIN	Description
	–	1	n.c.
	–	2	n.c.
	Digital mass potential	3	DGND Ground relating the RS-232C interface
	100% FS test	4	Control Off: 0 ... 2 VDC On: 3.5 ... 30 VDC
	RS-232C interface	5	TXD Serial send path of the torque sensor
		6	RXD Serial receive path of the torque sensor
		7	OGND

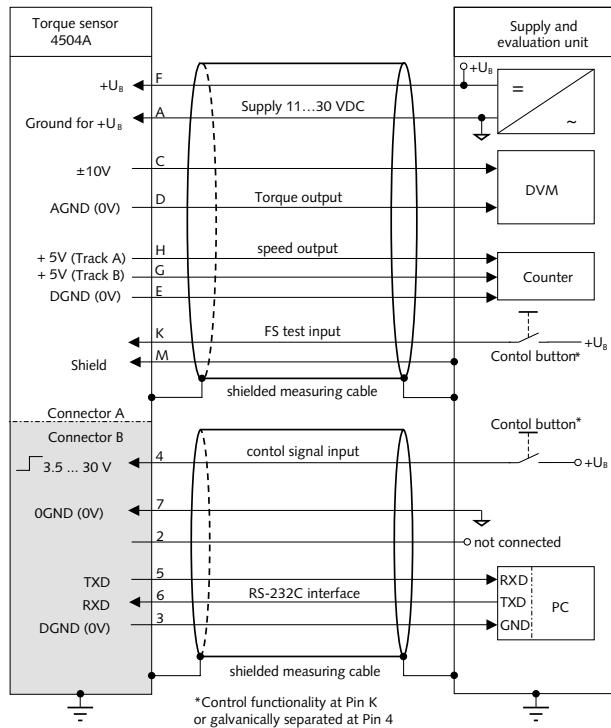

4504A_000-598a-11.06

Fig. 1: Pin allocation of the built-in connector A and B (standard)

Electrical Connections

Pin allocation of the 7 pin built-in connector C, option B5 or B6

Designation	Voltage	Frequency	PIN	Description	
				Voltage	Frequency
AGND		F_B /DGND*	1	Reference for U_A	10 kHz \pm 5 kHz, signal: 5 VDC RS-422/*Reference point for 12 VDC signal (optional)
	GND		2		$+U_B$
	$+U_B$		3		+11 ... +30 VDC, power input 4 W
U_A		F_A	4	\pm 10 VDC at $\pm M_{nom}$ at >2 k Ω , +10 VDC at control signal activation, $R_{i,c} = 10 \Omega$, short circuit protected to AGND	10 kHz at $\pm M_{nom}$ at > 2 k Ω , 15 kHz at control signal activation, signal: 5 VDC RS-422/12 VDC (optional)
n.c.		SGND	5	-	Reference point for RS-422 signals (optional)
	Control		6	Potential free control input Off: 0 ... 2 VDC/ On: 3.5 ... 30 VDC, $R_{i,k} = 10$ k Ω	
	KGND		7	Reference for control	

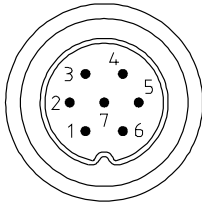

Pin allocation of the 8 pin built-in connector D, option B5 or B6

PIN	Description
1	Track A RS-422, double frequency TTL signal (optional)
2	not connected
3	Track B RS-422
4	not connected
5	not connected
6	Track A RS-422
7	Track B RS-422 signal for direction of rotation (optional)
8	DGND

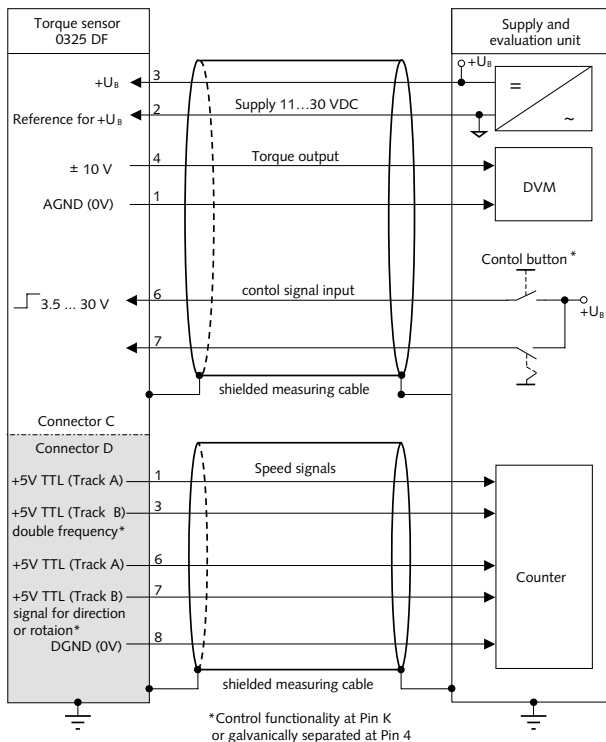
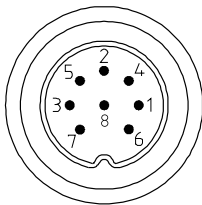

4504A_000-598a-11.06

Fig. 2: Pin allocation of the built-in connector C and D (option B5 or B6)

Mounting

Screw joint of rotor, Fastening bolts

Nominal torque Mnom	Nm (lbf-in)	200 (1770)	500 (4426)	1000 (8851)	2000 (17702)	3000 (26553)	5000 (44255)	10000 (88510)
Thread		M8	M12	M12	M14	M14	M18	M18
Quality class		10.9	10.9	10.9	10.9	10.9	10.9	10.9
Min. mounting depth	mm (in)	8 (0.3)	13 (0.5)	13 (0.5)	16 (0.6)	21 (0.8)	22.5 (0.9)	23 (0.9)
Max. mounting depth	mm (in)	16 (0.6)	22 (0.9)	22 (0.9)	26 (1)	31 (1.2)	39 (1.5)	41 (1.6)
Fastening torque Mfast	Nm (lbf-in)	34 (301)	100 (885)	115 (1018)	185 (1637)	185 (1637)	400 (3540)	470 (4160)
Balancing class	Q	6.3						
Counterflange flatness	mm (in)	6.3 (0.2)						
Counterflange concentric.	mm (in)	0.01 (0.0004)						
Max. delay rotor to stator		0.02 (0.0008)						
Axial	mm (in)	1 (0.04)						
Radial	mm (in)	2 (0.08)						

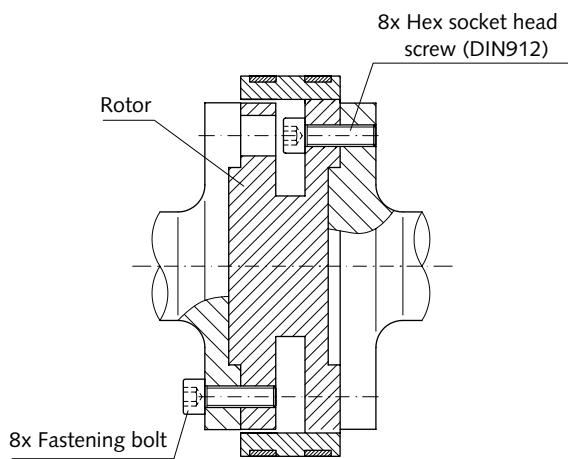

Screw-in depth has to be strictly observed !

Application Examples

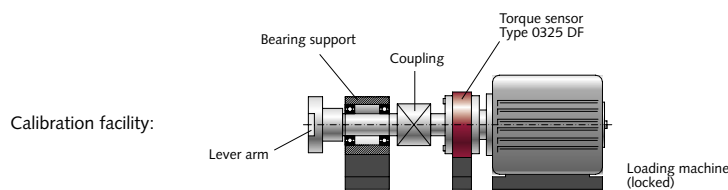
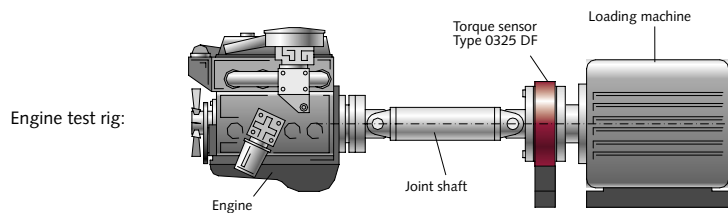

4504A_000-598a-11.06

Included Accessories

- Measuring flange
- Mating connector, 99-2030-09-12
- Certificate of performance (traceable calibration)

Art. No.

KSM000703

Ordering Key

Type 4504A

Measuring ranges in Nm (lbf-in)

200 (1,770)	200
500 (4,425)	500
1,000 (8,851)	1K
2,000 (17,700)	2K
3,000 (26,550)	3K
5,000 (44,250)	5K
10,000 (88,505)	10K

Optional Accessories

- Installation set for 19" rack mounting
- 5 m connecting cable
- Adapter flanges (on request)
- Couplings (on request)

Art. No.

KSM007203

Options Signal*

Analog out 0 ±10V	B1
Frequency output 100 kHz	B2
Frequency output 60 kHz	B3
Frequency output 10 kHz	B4

Our torque calibration service lab DKD-K-37701 offers traceable recalibration of any brands

Order example without options:

Type 4504A1KB1000N1

Torque sensor: rated torque **1,000** Nm (8851 lbf-in),,
Standard output signal ±10 VDC

Increased Accuracy

Without	0
Increased accuracy	C

Order example with options:

Type 4504A1KB20010N2

Torque sensor: rated torque **1,000** Nm (8851 lbf-in),
B2: frequency output TTL, **N2**: Speed measurement with 2x720 pulses

Interface

Without	00
RS-232C calibration	D1

Connector

Without	0
Connector C + D	P

Speed*

Speed measurement with 60 pulses	N1
Speed measurement with 2x720 pulses	N2
Speed measurement with 2x1 024 pulses	N3

* One option has to be defined

4504A_000-598a-11.06