

Type 8810

8810 K-GUARD® VIBRATION SWITCH

The model 8810 K-GUARD is a stand-alone electronic vibration monitoring device that guards machinery against excessive vibration levels caused by imbalance, misalignment, looseness, worn bearings, etc. When high vibration levels are detected, a relay is

activated that can be used for machine shutdown or to warn the operator of potential danger. Unlike mechanical switches, the 8810 features high accuracy, reliability and protects against false triggering. The K-GUARD is mounted directly on the desired measurement

Continued

- Solid state
- Velocity trip
- Monitor outputs
- Reliable accurate, and rugged
- Adjustable time delay
- Small size and lightweight
- Conforming to CE



Technical Data	Units	8810
Frequency Range -3 dB	Hz	10 ... 1000
	CPM	600 ... 60000
Velocity Range peak	in/sec (mm/sec)	4 (100)
Velocity Setpoint		
Setpoint Range field adjustable	in/sec (mm/sec)	0.08 ... 2 (2 ... 50)
Setpoint Accuracy	%	±10
Time Delay field adjustable	sec	1 ... 10
Number of Alarm Trips		1
Velocity Signal Output (analog voltage)		
Impedance	Ω	500
Current	mA	5
Voltage Range max.	V	±5
Sensitivity peak	mV/in/sec (mV/mm/sec)	1250 (50)
True_{rms} Velocity Output		
Output Current	mA	4 ... 20
Corresponding	in/sec (mm/sec) rms	0 ... 2 (0 ... 50)
Voltage max.	V	15
Alarm or Shutdown Outputs		
Relay	type	SPDT w/ NO and NC output
Current max. @ 30 VDC	A	1
Voltage max.	V	50
Cable Termination	type	pigtails
Power		
Voltage	VDC	18 ... 30
Current max.	mA	50
Integral Cable length	ft (m)	10 (3)
Cable Termination	type	pigtails
Environmental		
Storage Temperature	°F (°C)	-4 ... 185 (-20 ... 85)
Operating Temperature		32 ... 140 (0 ... 60)
Humidity	%	10 ... 90
Protective Classifications	NEMA (IP)	4x (65)
Weight	oz (kg)	14 (0.4)

1 g = 9.80665 m/s², 1 inch = 25.4 mm, 1 gram = 0.03527 oz

Kistler Instrument Corporation reserves the right to discontinue or change specifications, designs or materials without notice consistent with sound engineering principles and quality practices.

Kistler Instrument Corporation, 75 John Glenn Drive, Amherst NY 14228
Phone 716-691-5100, Fax 716-691-5226, e-mail: kicsales@kistler.com, www.kistler.com

point of the machine to be monitored. The small size makes installation possible in tight places on most types of industrial machinery. Outputs are provided that will interface with virtually all types of controls and annunciator. A mechanical relay, used to activate the external circuitry, eliminates the interface problems associated with solid state relays and permits the switching of either AC or DC power.

An internally mounted accelerometer converts the mechanical vibration into an electrical signal. The acceleration signal is integrated to velocity. Velocity is the desired unit of measurement since it offers uniform sensitivity to all frequencies within the measuring range. A plug-in low pass filter improves the unit resolution and filters out unwanted high frequency noise.

Variable velocity set point and time delay adjustments are located inside the unit. A built-in LED is provided to show when the unit is in an alarm condition, providing a simplified method for establishing set points. Once the user sets the trip level and delay, the unit's cover is replaced to ensure watertight, tamper-free operation. The variable time delay prevents false shutdowns caused by transient increases in vibration.

The vibration signal is available for analysis instrumentation, i.e., oscilloscope, portable data collectors and FFT analyzers. A 4 to 20 mA current output is provided for use with recorders, indicators, etc. The regular mounting of the machine functions, using the above output signals, makes K-GUARD a valuable predictive maintenance tool. Early detection of pending malfunctions allow scheduling machinery maintenance downtime and ordering parts prior to shutdown.

The unit is constructed in a rugged, cast aluminum case with a protective coating. Designed to provide years of trouble free operation in a hostile environment, the K-GUARD meets the NEMA and IP watertight standards listed in the technical data area.

Applications

The K-GUARD is a cost-effective solution to vibration monitoring on cooling towers and machinery such as fans, motors, conveyers, centrifugal pumps, motor/generator sets and other types of industrial machinery. K-GUARD is an ideal replacement for unreliable mechanical switches.

Related Product - 8812

Type 8812 provides a low impedance, voltage mode input connector for powering an external accelerometer with a sensitivity of 100 mV/g. Request data bulletin K8.8812.

Supplied Accessory

5327A1 low pass filter, 1 kHz

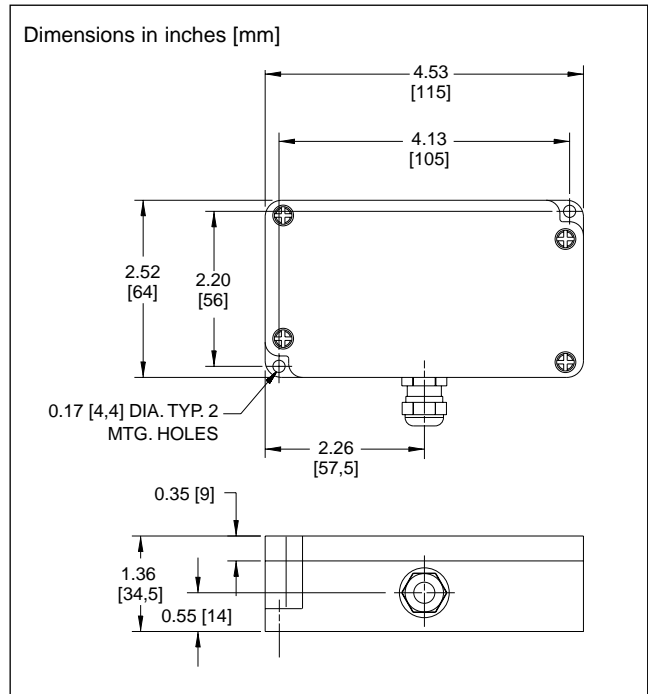
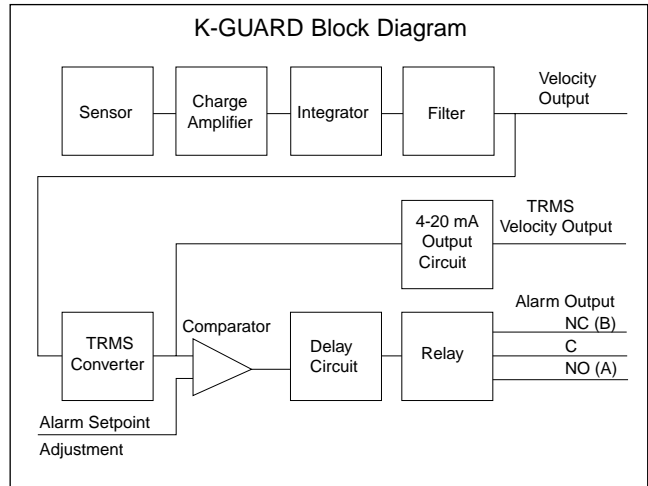

Connections

- Red +24 Volt power input
- Yellow Velocity Output
- Orange RMS velocity output 4-20 mA
- Black Power Return and signal common
- White Alarm Relay Normally Open (A)
- Blue Alarm Relay Common (C)
- Brown Alarm Relay Normally Closed (B)
- Green Case Ground

000-268e-04.01 (DBK8.8810e)