

Weatherproof Tubular Slip Ring Assembly

Model B6-2W

- ◆ 6 circuit weatherproof slip ring
- ◆ Compact design
- ◆ Mounts on shafts up to 2" in diameter
- ◆ Permanently lubricated bearings
- ◆ Rugged stainless steel construction
- ◆ Instrumentation quality rings and brushes

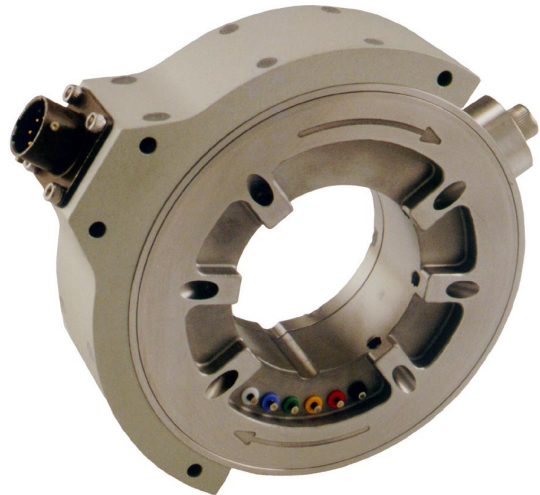

Description

The Michigan Scientific *B6-2W Weatherproof Slip Ring Assembly* is ideal for applications which require the slip ring to be sealed and mounted directly on a rotating shaft. It is typically used for automotive drive shaft measurement applications. This model employs specially designed seals that provide complete weatherproof protection from water, dust, and other contaminants. It is designed to fit on shafts up to 2" in diameter and make electrical connection to strain gages, thermocouples, or other sensors that have been installed on rotating equipment. The slip ring brushes and rings are made of precious metals which minimize noise and enable the assemblies to be used for low level instrumentation signals.

The six circuit capacity of this slip ring allows for more than one full bridge strain gage measurement channel. This is particularly useful for drive shaft applications where both torque and axial measurements are needed. In addition, the *B6-2W* provides enough circuit connections for use with spinning amplifiers. Locating precision amplifiers on the rotating side of the slip ring greatly improves signal quality because the amplifier is located closer to the sensor. This reduces errors due to long lead wires, connector resistance variations, electro-magnetic interference, and temperature gradients across slip ring contacts.

Connections are made through color coded solder terminals located on the slip ring rotor and a connector on the slip ring stator. The compact design of these slip rings make them ideal for applications where limited space is available.

Specifications

Circuits	6
Current Capacity Per Circuit	1 A
Temperature Range	-40°F to 250°F (-40°C to 121°C)
RPM Rating	7000 RPM
Maximum Peak Noise*	0.1 Ω
Width	1.264 in (32.11 mm)
Weight	2.75 lbs (1.25 kg)
Output Connector	Bendix PT02E-10-6P
Mating Connector	Bendix PT06E-10-6S (SR)

*Resistance variation across slip ring contact.

Weatherproof Tubular Slip Ring Assembly

B6-2W CONFIGURATION

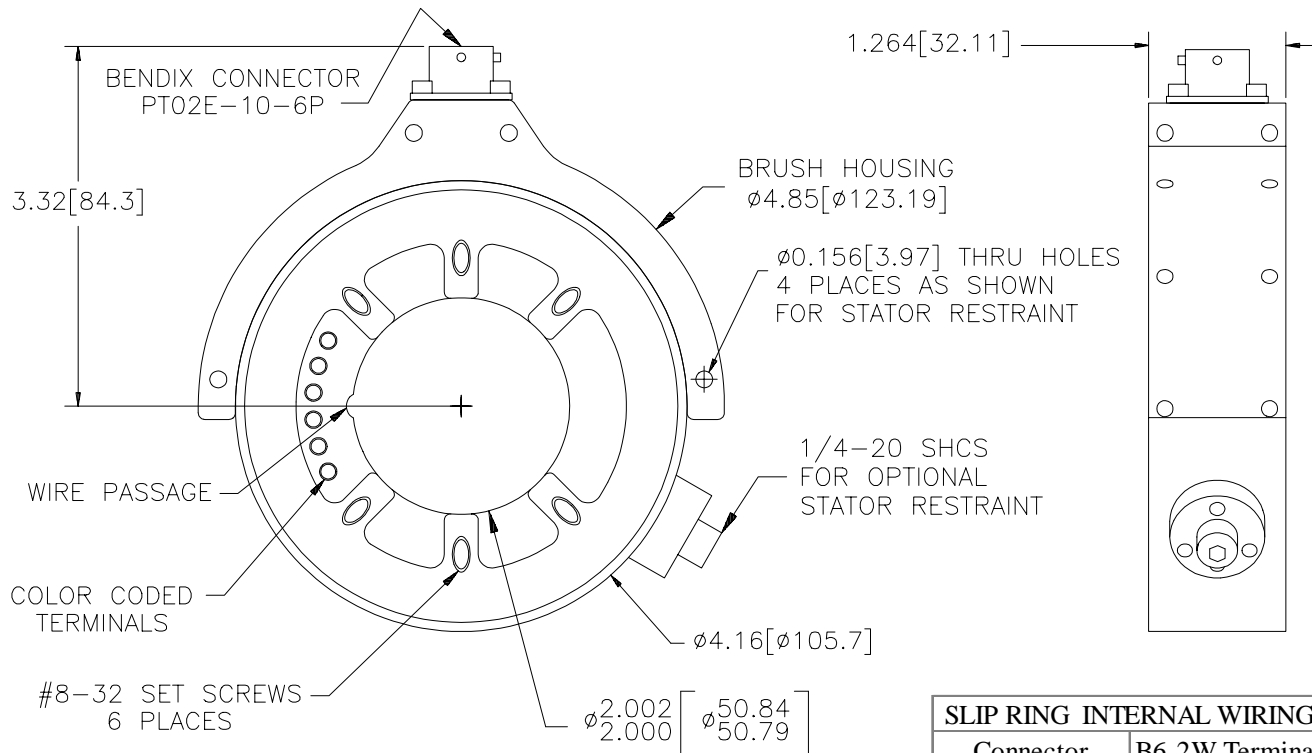

DIMENSIONS ARE INCH[mm]

SLIP RING INTERNAL WIRING	
Connector	B6-2W Terminal
Pin A	White
Pin B	Blue
Pin C	Green
Pin D	Yellow
Pin E	Red
Pin F	Black

Mounting

The *B6-2W Slip Ring Assembly* can be easily mounted on a shaft. An additional bushing is required when using the slip rings on shafts smaller than 2" in diameter. The slip ring rotor is configured with six #8-32 set screws used for mounting. Signal wires from the sensors can be routed along the outside diameter of the shaft. A wire path slot is machined into the slip ring rotor, enabling wires to be routed under the slip ring and to the color coded solder terminals.

Ordering Options

- Special units are available for high speed applications that continuously exceed 7000 RPM. Contact Michigan Scientific for further information.
- The slip ring rotates in both clockwise and counterclockwise directions, however, an optimal sealing direction may be specified.
- Mating Bendix connector is included. For information regarding slip ring accessories, refer to the "Price List and Accessories" section.