

# S Series Slip Ring Assembly

## Models S4, S6, S8, S10

- ◆ 4, 6, 8, and 10 circuit slip rings
- ◆ Sealed against dust
- ◆ Color coded terminals
- ◆ Lightweight and compact
- ◆ Permanently lubricated bearings
- ◆ Rugged stainless steel construction
- ◆ Instrumentation quality rings and brushes



## Description

The Michigan Scientific *S Series Slip Ring Assemblies* are utilized for a variety of applications requiring up to 10 circuit connections. They are designed to mount on the end of a rotating shaft and make electrical connection to strain gages, thermocouples, or other sensors that have been installed on rotating equipment. The slip ring brushes and rings are made of precious metals which minimize noise and enable the assemblies to be used for low level instrumentation signals. In addition, a high grade stainless steel case provides protection from dust and other contaminants.

The S Series models are available in 4, 6, 8, and 10 circuit slip ring assemblies. Connections are made through color coded solder terminals located on both the slip ring rotor and slip ring stator. Permanently lubricated bearings eliminate the need for routine cleaning and maintenance. The lightweight and compact design of these slip ring assemblies make them ideal for use in applications where limited space is available.

## Specifications

	S4	S6	S8	S10
Circuits	4	6	8	10
Current Capacity Per Circuit	500 mA	500 mA	500 mA	500 mA
Temperature Range*	-40°F to 250°F (-40°C to 121°C)	-40°F to 250°F (-40°C to 121°C)	-40°F to 250°F (-40°C to 121°C)	-40°F to 250°F (-40°C to 121°C)
RPM Rating	12000 RPM	12000 RPM	12000 RPM	12000 RPM
Maximum Peak Noise**	0.1 $\Omega$	0.1 $\Omega$	0.1 $\Omega$	0.1 $\Omega$
Weight	3.9 oz (111 g)	4.0 oz (113 g)	4.1 oz (116 g)	4.2 oz (119 g)
Length "A" (see back)	1.3 in (33 mm)	1.4 in (36 mm)	1.6 in (41 mm)	1.6 in (41 mm)

\*For operation below 0°F, specify low temperature lubricant.

\*\*Resistance variation across slip ring contact.

# S Series Slip Ring Assembly

## S-SERIES CONFIGURATION

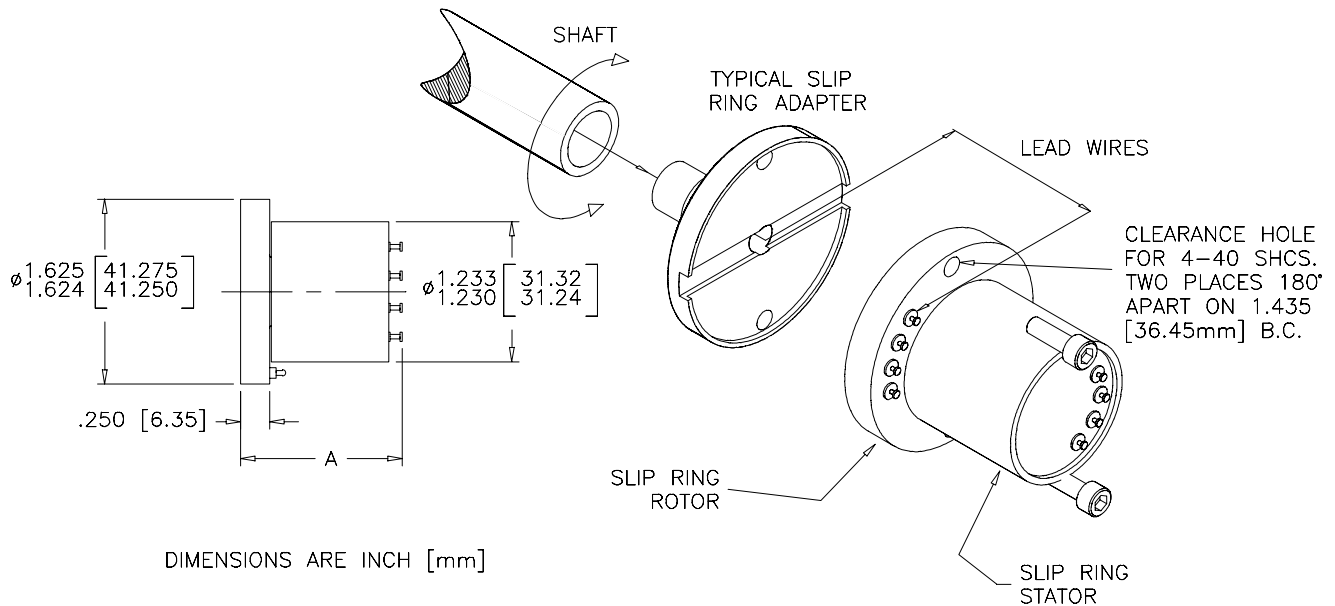

## Mounting

The *S Series Slip Ring Assemblies* can easily be mounted to the end of a shaft. An adapter (shown above) may be required for mounting the slip ring to an instrumented shaft. The slip ring rotor is configured with two #4-40 clearance holes, 180° apart, used for mounting. Signal wires from the sensor can be routed along the outside diameter of the shaft or through the center of a hollow shaft. A slot must be machined in the shaft or adapter to open a pathway to the slip ring rotor terminals when signal leads are routed through the center of the shaft.

Contact Michigan Scientific for applications in which the slip ring assemblies are subjected to extreme vibration.

## Ordering Options

For information regarding slip ring accessories, refer to the "Price List and Accessories" section.