

Model 801

Planar Beam Sensor

- Measures force, pressure, displacement or acceleration
- Thermally matched, fully active, full bridge gauge for optimum temperature tracking
- Compatible with automated assembly techniques

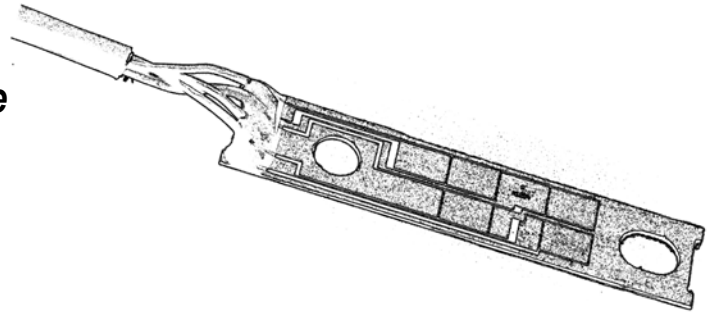

specifications

Capacity [lb (kg)]	0.25, 0.5, 1.0, 2.0, 5.0 (0.11, 0.23, 0.45, 0.91, 2.27)	Zero Balance (%FS)	15.0
Insulation Resistance (megaohm @ 50Vdc)	1000 minimum	Comp. Temp. Range	20 to 120°F (-7 to 49°C)
Rated Output (mV/V)	2.0±0.4	Operating Temp. Range	-65 to 200°F (-54 to 93°C)
Bridge Resistance (input)	1200±300Ω	Temperature Sensitivity: Output (%FS/°F)	±0.02
Bridge Resistance (output)	1200±300Ω	Temperature Sensitivity: Zero Balance (%FS/°F)	0.25-0.5: ±0.03; 1.0-5.0: ±0.02
Excitation Voltage	10Vdc (12V max)	Safe Overload (%FS)	150
Combined Error (%FS) ^{1,2}	0.25 max	Safe Sideboard (%FS)	200
		Deflection at Full Scale ²	0.005 to 0.025 inches

(1) The maximum deviation for both increasing and decreasing load from a straight line between no load and rate load at constant temperature; includes effects of non-linearity, hysteresis, and non-repeatability.

(2) Actual levels depend on beam clamping method.

NOTE: Specifications subject to change. Request certified drawings prior to designing mountings or fixtures.

Dimensions in inches (millimeters).

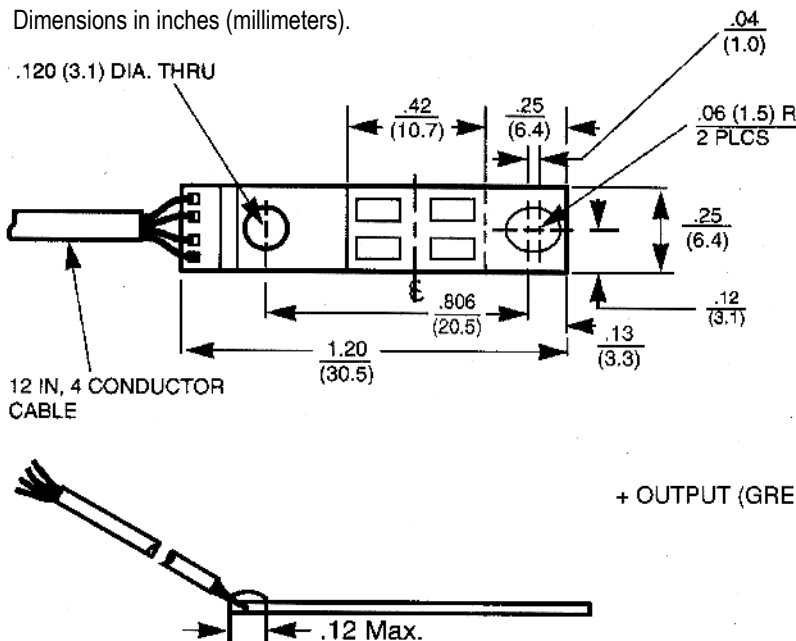

Electrical Connection

+ Excitation	Red
- Excitation	Black
+ Signal	Green
- Signal	White
Shield	Silver

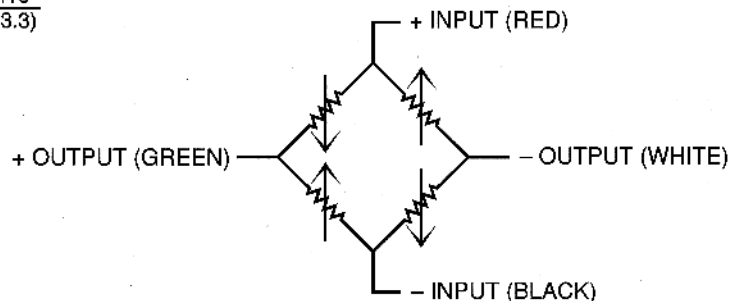

INTERTECHNOLOGY
INC.

1-800-465-1600

1 Scarsdale Road
Don Mills, Ontario
M3B 2R2

Tel: 416-445-5500, Fax: 416-445-1170

E-Mail: sales@intertechnology.ca

ISO9001
Certified