

## MODEL 60063

### STAINLESS STEEL, WELDED SEAL S-BEAM LOAD CELL

#### APPLICATIONS

- Hostile environments
  - Food and beverage processing
  - Chemical and plastics processing
  - Pharmaceutical and biomedical processing
- Bin, hopper and belt conveyor scales
- Level and inventory monitoring
- Truck scale conversions
- Tension and compression measurements

#### FEATURES

- Rated capacities of 500 to 20,000 pounds
- Stainless steel, welded seal construction
- Integral loading brackets
- Compatible with TCM tension mounting hardware
- Mounting and loading accessory hardware available
- Designed for single or multiple load cell applications
- Trade certified for NTEP Class III L:10,000 divisions and III:5,000 divisions
- **Sensorgage™** sealed to IP67 standards
- **Cell Guard™** Two Year Warranty
- Factory Mutual System Approved for Classes I, II, III;  
Divisions 1 and 2; Groups A through G.  
Also, **Non-Incendive** (No Barriers!) also.
- ISO 9001 Certified manufacturing facilities



ISO  
9001



Factory  
Mutual  
System  
Approved

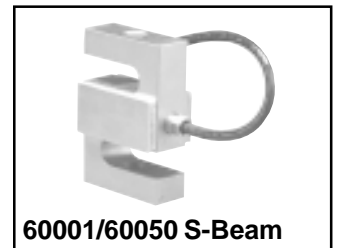

# Model 60063 Performance Specifications

Rated Capacities (lbs): 500, 750, 1K, 1.5K, 2K, 2.5K, 3K, 5K, 10K, 15K, 20K

Full Scale Output (FSO): 2.0 mV/V +25% / -10%

Accuracy Class:	Standard	NTEP III <sup>(1)</sup>	NTEP IIII <sup>(1)</sup>
Combined Error % FSO	≤ .03	5,000	10,000
Non-Linearity % FSO	≤ .03	Multiple	
Hysteresis % FSO	≤ .02	--	--
Creep Error % FSO	≤ 0.03 in 20 minutes	--	--
Temperature Effect on:			
• Zero % FSO/°F	≤ 0.0015	--	--
• Output % of Load/°F	≤ 0.0008	--	--
Non-Repeatability % FSO		≤ .01	
Zero Balance % FSO		≤ 1.0	
Insulation Resistance		> 1000 Mohms at 50VDC	
Compensated Temperature Range		14° to 104°F / -10° to 40°C	
Operating Temperature Range		0° to 150°F / -18° to 65°C	
Storage Temperature Range		-60° to 185°F / -50° to 85°C	
Input Resistance		349-450 Ohms	
Output Resistance		349-355 Ohms	
Recommended Excitation Voltage		10 Volts DC	
Maximum Excitation Voltage		15 Volts DC	
Safe Overload		150% of Rated Capacity	
Ultimate Overload		300% of Rated Capacity	
Sealing		Meets IP67 Standards	
Material		17-4 PH Stainless Steel	

<sup>(1)</sup>Note: 500 to 5K Capacities Only.

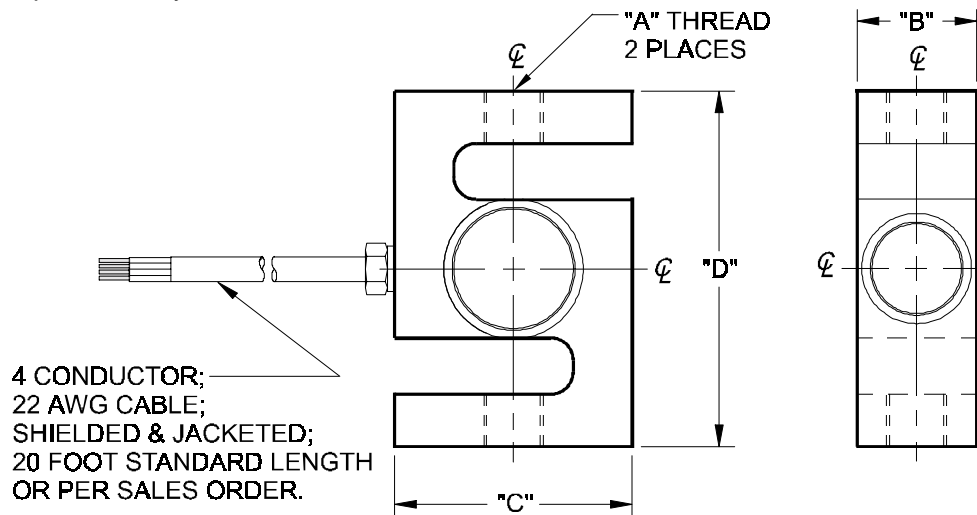

## WIRING

FUNCTION	COLOR
+ Excitation	Red
- Excitation	Black
+ Output	Green
- Output	White

CAPACITY	A	B	C	D	Deflection	Weight
500 - 3K	1/2-20	1.00	2.00	3.00	0.010	3.00
5K - 10K	3/4-16	1.00	3.50	4.75	0.010	5.00
15K	1-14	1.25	4.00	5.50	0.010	8.00
20K	1 1/4-12	2.00	5.00	7.00	0.010	19.00

Dimensions are in inches. Capacities are in pounds. Deflection is ±10%. Specifications are subject to change. Certified drawings are available.