

MODEL 65080

STAINLESS STEEL, WELDED SEAL TANTAMOUNT WEIGH MODULE

APPLICATIONS

- Hostile environments
 - Food & beverage processing
 - Chemical and plastics processing
 - Pharmaceutical and biomedical processing
- Washdown
- Tank and reactor weighing
- Batching, blending and mixing

FEATURES

- Capacity ranges of 1,000 to 20,000 pounds
- Mounts directly to floor or structural support
- Integral height adjustment for easy load balancing
- Articulating mounting plate accommodates non-planar misalignments of up to 4°
- Mounting plates allow for thermal expansion/contraction
- Employs 65083 stainless steel, welded seal shear beam load cell
- High output - well suited to high deadload/low liveload situations
- Integral conduit adaptor and Teflon jacketed cable
- Optional hermetically sealed version meets IP66/68 standards
- Trade certified for NTEP Class III L:10,000 divisions;
Class III:5,000 divisions and OIML R60 3,000 divisions in 1,000 to 10,000 pound range
- **Sensorgage™** sealed to IP66/67 standards
- **Cell Guard™** Two Year Warranty
- Factory Mutual System Approved for Classes I, II, III; Divisions 1 and 2; Groups A through G.
Also, **Non-Incendive** ratings (No Barriers!).
- ISO 9001 Certified manufacturing facilities

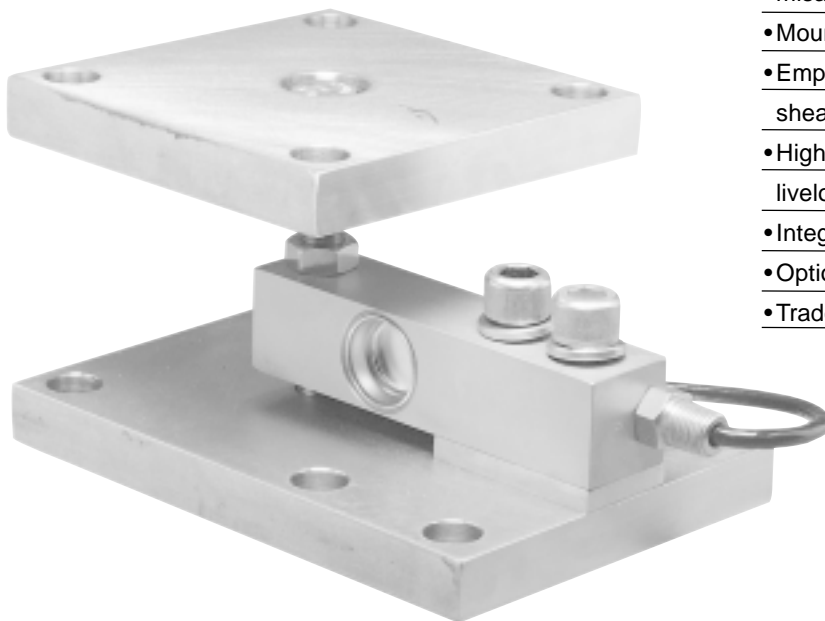

Model 65080 Performance Specifications

Rated Capacities (lbs): 1K, 1.5K, 2.5K, 4K, 5K, 10K, 15K, 20K
 Full Scale Output (FSO): 2.0 mV/V \pm 0.25%

Accuracy Class:	Standard	NTEP III ⁽¹⁾	NTEP IIII ⁽¹⁾	OIML R60 ⁽¹⁾
Max. No. Verification Intervals	--	5,000 Multiple	10,000 Multiple	3,000
Combined Error % FSO	$\leq .03$	--	--	--
Non-Linearity % FSO	$\leq .03$	--	--	--
Hysteresis % FSO	$\leq .02$	--	--	--
Creep Error % FSO	$\leq .03$ in 20 minutes	--	--	--
Temperature Effect on:				
• Zero % FSO/°F	≤ 0.0015	--	--	--
• Output % of Load/°F	≤ 0.0008	--	--	--
Non-Repeatability % FSO			$\leq .01$	
Zero Balance % FSO			≤ 1.0	
Insulation Resistance		> 1000 Mohms at 50VDC		
Compensated Temperature Range		14° to 104°F / -10° to 40°C		
Operating Temperature Range		0° to 150°F / -18° to 65°C		
Storage Temperature Range		-60° to 185°F / -50° to 85°C		
Input Resistance		343-357 Ohms		
Output Resistance		349-355 Ohms		
Recommended Excitation Voltage		10 Volts DC		
Maximum Excitation Voltage		15 Volts DC		
Sideload Rejection Ratio		500:1		
Safe Sideload		30% of Rated Capacity		
Safe Overload		150% of Rated Capacity		
Ultimate Overload		300% of Rated Capacity		
Sealing		Meets IP66/67 Standards		
Material		Stainless Steel		

⁽¹⁾ Note: 1K - 10K Capacities Only

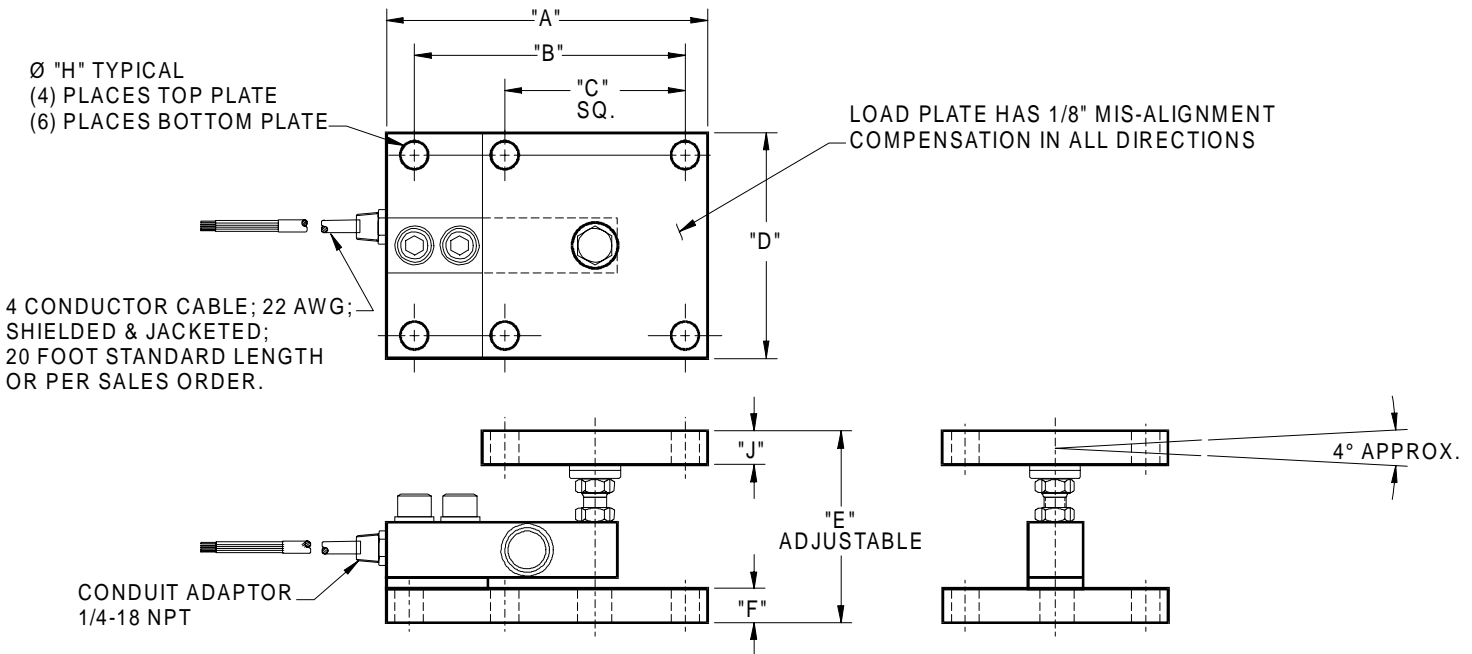

WIRING

FUNCTION	COLOR
+ Excitation	Red
- Excitation	Black
+ Output	Green
- Output	White

CAPACITY	A	B	C	D	E	F	H	J	Weight
1K - 4K	7.12	6.00	4.00	5.00	4.00 - 4.50	0.70	0.63	0.70	17.0
5K - 10K	8.50	7.00	4.00	5.00	5.00 - 5.50	0.94	0.63	0.94	25.0
15K - 20K	10.88	9.13	4.50	6.00	7.00 - 7.50	1.44	0.88	1.20	49.0

Dimensions are in inches. Capacities are in pounds. Specifications are subject to change. Certified drawings are available.