

## MODEL 65083

### STAINLESS STEEL, WELDED SEAL SHEAR BEAM LOAD CELL

#### APPLICATIONS

- Hostile environments
  - Food & beverage processing
  - Chemical and plastics processing
  - Pharmaceutical and biomedical processing
- Washdown and Clean-In-Place environments
- Tank, bin and hopper weighing
- Batching, blending and mixing systems

#### FEATURES

- Rated capacities of 1,000 to 20,000 pounds
- Stainless steel, welded seal construction
- Interchangeable with standard Sensortronics shear beams
- Companion weigh module available
  - 65080 Stainless Steel *TantaMount*
- Extended temperature ranges available
- Integral conduit adaptor with teflon jacketed cable available
- **Sensorgage™** sealed to IP66/67 standards
- **Cell Guard™** Two Year Warranty
- Factory Mutual System Approved for Classes I, II, III;  
Divisions 1 and 2; Groups A through G.  
Also, **Non-Incendive** ratings (No Barriers!)
- ISO 9001 Certified manufacturing facilities

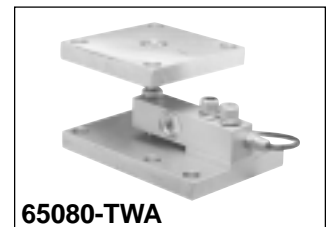

ISO  
9001



Factory  
Mutual  
System  
Approved



65080-TWA

# Model 65083 Performance Specifications

Rated Capacities (lbs): 1K, 1.5K, 2.5K, 4K, 5K, 10K, 15K, 20K

Full Scale Output (FSO): 2.0 mV/V  $\pm$  0.25%

Accuracy Class:	Standard	NTEP III <sup>(1)</sup>	NTEP IIII <sup>(1)</sup>	OIML R60 <sup>(1)</sup>
Max. No. Verification Intervals	--	5,000 Multiple	10,000 Multiple	3,000 Multiple
Combined Error % FSO	$\leq .03$	--	--	--
Non-Linearity % FSO	$\leq .03$	--	--	--
Hysteresis % FSO	$\leq .02$	--	--	--
Creep Error % FSO	$\leq .03$ in 20 minutes	--	--	--
Temperature Effect on:				
• Zero % FSO/°F	$\leq 0.0015$	--	--	--
• Output % of Load/°F	$\leq 0.0008$	--	--	--
Non-Repeatability % FSO		$\leq .01$		
Zero Balance % FSO		$\leq 1.0$		
Insulation Resistance		> 1000 Mohms at 50VDC		
Compensated Temperature Range		14° to 104°F / -10° to 40°C		
Operating Temperature Range		0° to 150°F / -18° to 65°C		
Storage Temperature Range		-60° to 185°F / -50° to 85°C		
Input Resistance		343-357 Ohms		
Output Resistance		349-355 Ohms		
Recommended Excitation Voltage		10 Volts DC		
Maximum Excitation Voltage		15 Volts DC		
Sideload Rejection Ratio		500:1		
Safe Sideload		100% of Rated Capacity		
Safe Overload		150% of Rated Capacity		
Ultimate Overload		300% of Rated Capacity		
Sealing		Meets IP66/67 Standards		
Material		Stainless Steel		

<sup>(1)</sup> Note: 1K -10K Capacities Only

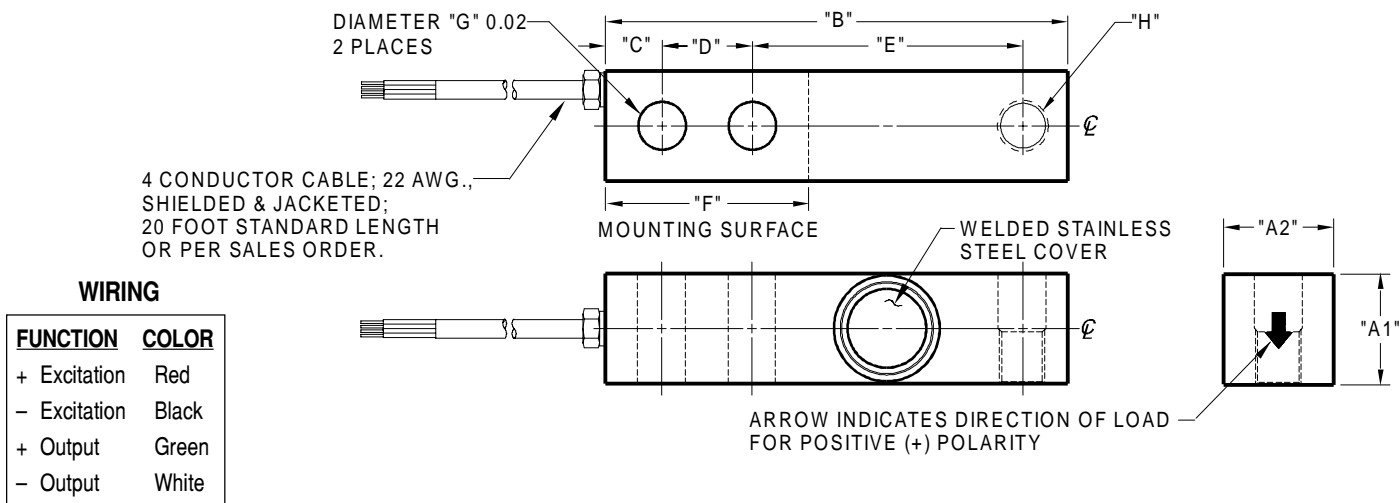

CAPACITY	A1	A2	B	C	D	E	F	G	H	Deflection	Weight
1K - 4K	1.22	1.22	5.12	0.62	1.00	3.00	2.25	0.53	1/2-20 UNF-2B, $\emptyset$ 0.53 x 0.61 DEEP C'BORE	0.008 - 0.026	4.0
5K-SE*	1.22	1.22	5.12	0.62	1.00	3.00	2.25	0.53	1/2-20 UNF-2B, $\emptyset$ 0.53 x 0.61 DEEP C'BORE	0.008 - 0.026	4.0
5K - 10K	1.50	1.50	6.75	0.75	1.50	3.75	3.00	0.78	3/4-16 UNF-2B, $\emptyset$ 0.78 x 0.75 DEEP C'BORE	0.030 - 0.055	6.5
15K -20K	2.00	2.00	8.75	1.00	2.00	4.88	4.00	1.06	1-14 UNS-2B, $\emptyset$ 1.06 x 1.00 DEEP C'BORE	0.025 - 0.032	9.0

Dimensions are in inches. Capacities are in pounds. Deflection is  $\pm$ 10%. Specifications are subject to change. Certified drawings are available.

\*SE denotes "Small Envelope". A 5K capacity is available in the 1K/4K dimensional envelope.