

## MODEL 65088-0114

### STAINLESS STEEL MULTI-COLUMN COMPRESSION LOAD CELL

#### APPLICATIONS

- Truck scales
- Railroad track scales
- Tank, bin and silo weighing applications

#### FEATURES

- Rated capacities of 50,000 to 200,000 pounds,  
23 to 91 metric tons
- Stainless steel, welded seal construction
- Multi-column *monolithic element* design
- 35 feet standard cable length
- Three times side loading tolerance relative to similar  
competitive products
- Reduced eccentric loading sensitivity
- Integral conduit adaptor
- Replacement for models RTI 792 and BLH C2P1
- Trade certified for NTEP Class III L:10,000 divisions; III:5,000  
divisions and OIML R60 3,000 divisions
- Welded **Sensorgage™** sealed to IP66/67 standards
- **Cell Guard™** Two Year Warranty
- ISO 9001 Certified manufacturing facilities



# Model 65088-0114 Performance Specifications

Rated Capacities (lbs): 50K, 100K, 200K  
 (metric tons): 23t, 45t, 91t  
 Full Scale Output (FSO): 2.0 mV/V ± 0.50%

Accuracy Class:	Standard	NTEP III	NTEP IIIIL	OIML R60
Max. No. Verification Intervals	--	5,000 Multiple	10,000 Multiple	3,000
Combined Error % FSO	≤ .03	--	--	--
Non-Linearity % FSO	≤ .03	--	--	--
Hysteresis % FSO	≤ .02	--	--	--
Creep Error % FSO	≤ .03 in 20 minutes	--	--	--
Temperature Effect on:				
•Zero % FSO/°F	≤ 0.0015	--	--	--
•Output % of Load/°F	≤ 0.0008	--	--	--
Non-Repeatability % FSO			≤ .01	
Zero Balance % FSO			≤ 1.0	
Insulation Resistance		> 1000 Mohms at 50VDC		
Compensated Temperature Range		14° to 104°F / -10° to 40°C		
Operating Temperature Range		0° to 150°F / -18° to 65°C		
Storage Temperature Range		-60° to 185°F / -50° to 85°C		
Input Resistance		350 ±3.5 Ohms		
Output Resistance		350 ±3.5 Ohms		
Recommended Excitation Voltage		10 Volts DC		
Maximum Excitation Voltage		25 Volts DC		
Safe Sideload		30% of Rated Capacity		
Safe Overload		150% of Rated Capacity		
Ultimate Overload		300% of Rated Capacity		
Sealing		Meets IP66/67 Standards		
Material:		15-5 PH Stainless Steel		
•Element		304 Stainless Steel		
•Canister				

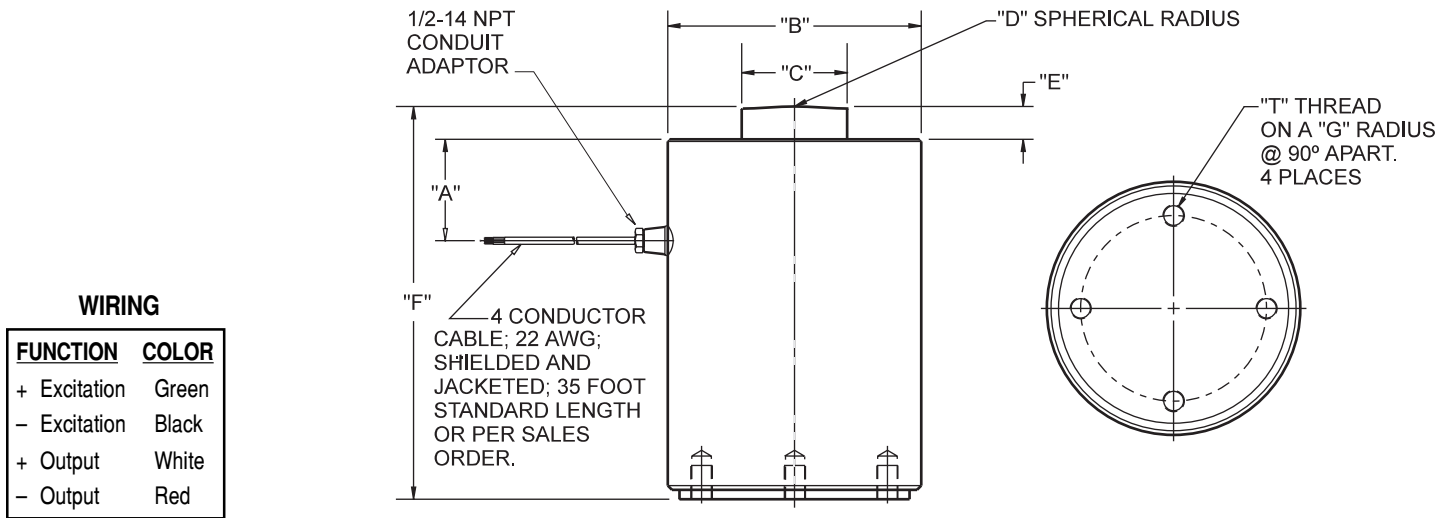

## WIRING

FUNCTION	COLOR
+ Excitation	Green
- Excitation	Black
+ Output	White
- Output	Red

CAPACITY	A	B	C	D	E	F	G	T	Deflection	Weight
50K (23t)	1.17 (29.7)	4.50 (114.3)	1.25 (31.7)	8.00 (203.2)	0.75 (19.0)	7.50 (190.5)	2.38 (60.5)	3/8-24 UNF-2B x .63 DEEP	0.003 (0.1)	15.0 (6.8)
100K (45t)	2.00 (50.8)	5.75 (146.0)	1.75 (44.5)	12.00 (304.8)	0.87 (22.1)	9.13 (231.9)	4.00 (101.6)	1/2-20 UNF-2B x .75 DEEP	0.006 (0.2)	35.0 (15.9)
200K (91t)	2.93 (74.4)	7.50 (190.5)	2.50 (63.5)	12.00 (304.8)	0.97 (24.6)	11.63 (295.4)	5.50 (139.7)	5/8-18 UNF-2B x 1.00 DEEP	0.006 (0.2)	55.0 (25.0)

Dimensions are in inches (millimeters). Capacities are in pounds (metric tons). Deflection is ±10%. Specifications are subject to change. Certified drawings are available.