

# Model 100

## Compression Load Cells



- ◆ Capacities: 5 - 60 tons (5,000 - 60,000 kg)
- ◆ Ideal for multi-cell applications
- ◆ Compact, economical, column design
- ◆ Hermetically sealed to IP67
- ◆ 6 Wire sense circuit
- ◆ Stainless steel housing optional
- ◆ Surge arrestors fitted

Model 100 is a heavy duty general purpose compression load cell particularly well suited for hopper and tank weighing and many other large scale industrial applications, including weighbridges for truck weighing.

The simple, compact column design and rugged hermetically sealed construction of the model 100 load cell assures its long term life in all types of field installations.

The model 100 load cell is often used in multi-cell installations, therefore its standard output tolerance is within 0.1%.

A full range of mounting accessories are available.

The two additional sense wires feed back the voltage reaching the load cell. Complete compensation of changes in lead resistance due to temperature change and / or cable extension, is achieved by feeding this voltage into the appropriate electronics.

# Model 100

# Compression Load Cells

GRADE	C	UNITS
Rated Capacities	5, 10, 15, 17, 20, 25, 30, 40, 50, 60	tons
Rated Output	2.0 ± 0.1%	mV/V
Total Error*	0.10	±% of Applied Load
Zero Return after 20 mins	0.10	±% of Applied Load
Temperature Effect : On Output	0.0050	±% of Applied Load / °C
Temperature Effect : On Zero	0.0050	±% of Rated Load Output / °C
Zero Balance	2.0	±% of Rated Output
Temperature range : Operating	-30 to +70	°C
Temperature range : Compensated	-10 to +45	°C
Safe Overload	150	% of Rated Capacity
Ultimate Overload	250	% of Rated Capacity
Excitation: Recommended	10	Volts AC or DC
Excitation: Maximum	15	Volts AC or DC
Input Impedance	375 ± 15	Ohms
Output Impedance	351 ± 3	Ohms
Insulation Impedance	>2000	Mega Ohms
Deflection at Rated Capacity	<0.4	mm
Weight :	5.0	kg
Construction: Standard	Epoxy coated steel	
Construction: Optional	Stainless Steel housing, plated alloy steel sensor	
Environmental Protection	IP67	
Cable	15 Meters (Standard), 6 Wire, PVC Jacket, Floating Screen	
Approvals		

\* Total Error - According to OIML R60 (Typical 80% Utilization)

Also Available In 75 And 100 Ton Capacities.

## Wiring Schematic Diagram

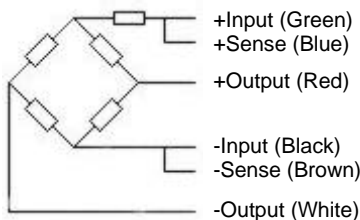

## Outline Dimensions All Capacities (in mm)

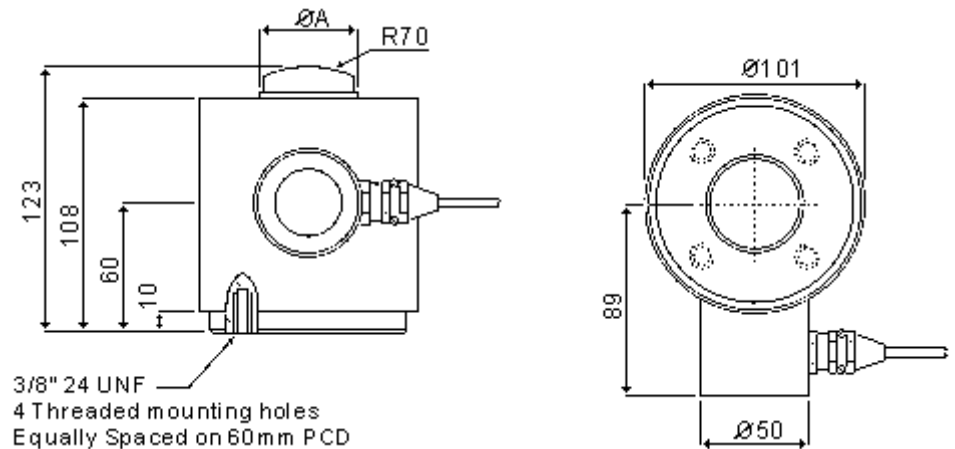

CAPACITY kg	ØA
5,000 - 20,000	28
25,000 - 60,000	45

**INTERTECHNOLOGY**  
INC.

1 Scarsdale Road, Don Mills, ON M3B 2R2  
 Tel: 416-445-5500, Fax: 416-445-1170  
 Toll Free: 1-800-465-1600  
 E-Mail: [sales@intertechnology.ca](mailto:sales@intertechnology.ca)