

TEDEA-HUNTLEIGH Model 1241

Single Point Load Cell

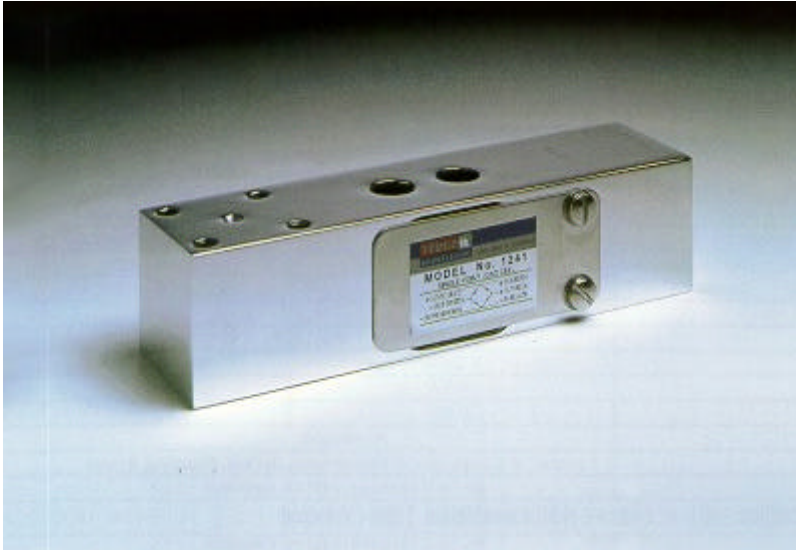

- **Capacities: 50 - 250 kg (110.23 - 551.17 lbs)**
- **Aluminum Construction**
- **Combined error only 0.02%**
- **Unique humidity-resistant protective coating**
- **6 wire (sense) circuit**
- **Low profile - 1.6" (40mm) in height**
- **Maximum safe moment to 30 X rated capacity (kg-cm)**
- **4 mounting holes for added stability**

Model 1241 is a low profile, three beam, off-center load cell designed for direct mounting to a weighing platform, hanging scale, or other eccentric loading applications.

It is one of the most compact designs available for these capacities which makes it especially well suited to scales which weigh people as well as high capacity industrial applications where space is limited.

This high accuracy load cell is Factory Mutual and OIML Class C3 Approved. When operated at constant temperature, all load cells offer 0.02% combined error performance regardless of accuracy class.

A unique humidity resistant protective coating assures longterm stability even under harsh environment and extreme temperatures. Optional Sylgard encapsulation is available for applications requiring washdown protection.

Tedea-Huntleigh, with models ranging from 2 to 50,000 kg capacities, is the world's largest manufacturer of precision load cells.



1241 SPECIFICATIONS

ACCURACY CLASS	E	F	G	UNITS
Rated Capacity	50, 100, 150, 200, 250			kg
Rated Output*	2.0 ± 10%			mV/V
Total Error**	1500	2000	3000	Divisions
Total Error for Eccentric Load of 0.33 Rated Capacity	0.0074	0.0074	0.0049	±% of Load / cm
Maximum Moment	30			kg - cm
Creep at Rated Capacity / Zero Return After 30 Minutes	0.050	0.025	0.017	±% of Load
Zero Balance	10.0			±% of Rated Output
Temperature Range : Safe	-30 to +70			°C
: Compensated	+10 to +40			°C
Temperature Effect : On Output	0.003	0.004	0.001	±% of Load / °C
: On Zero	0.010	0.006	0.0028	% of Rated Output / °C
Maximum Overload at the Center Loading Point	150			% of Rated Capacity
Ultimate Overload at the Center Loading Point	300			% of Rated Capacity
Excitation : Recommended	10			Volts AC or DC
: Maximum	15			Volts AC or DC
Input Impedance	415 ± 15			Ohms
Output Impedance	350 ± 3			Ohms
Insulation Resistance	>2000			Mega Ohms
Deflection at Rated Capacity	<0.4			mm
Weight	0.65			kg
Construction	Aluminum			
Cable	1 Meter, 6 Conductor, Polyurethane Jacket, Floating Shield			
Environmental Protection	IP 54 Standard / IP 65 Optional			
Approvals				

* All accuracy specifications maintained when 150% of nominal load is applied for 3 mV/V output

** Nonlinearity, hysteresis, repeatability, and output temperature effect according to OIML R60 and NIST H-44

Wiring Diagram and Dimensions

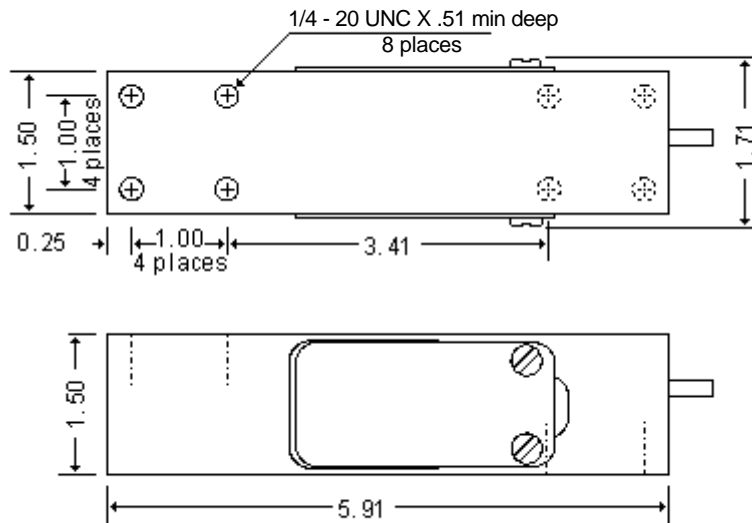

All Dimensions in inches

Balanced Temperature Compression

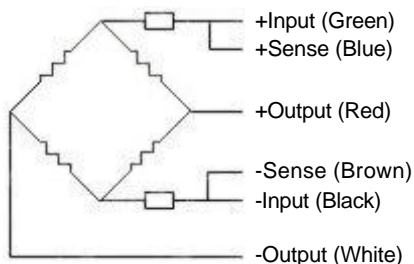

The two "sense" wires sample the bridge supply voltage at the load cell. Complete compensation of change in the lead wire resistance, due to temperature change and/or cable extension, is achieved by feeding this voltage into appropriate electronics.



Due to TedeA-Huntleigh's policy of continuous development, these specifications are subject to change without notice.