

### Features

- ◆ Simplifies load cell installation on tanks, silos and other weighing vessels
- ◆ Accepts load cells ranging in capacity from 11 lbs to 11,000 lbs (5 to 5,000 kg)
- ◆ Permanent protection against load cell damage
- ◆ Built in jacking points permit installation with or without load cells in place
- ◆ Grounding strap provides low resistance path to minimize electrical potentials
- ◆ Provision for thermal expansion, contraction and lift-off due to winds or collision
- ◆ Cable gland protector prevents cable damage

The Tedea-Huntleigh CellMate™ is a superior load cell mounting assembly that dramatically simplifies load cell installation.

A perfect solution to vessel weighing in dairies, chemical, bottling and food processing plants, stainless steel CellMate™ mounts can be used on tanks, silos and many other weighing vessels.

The CellMate™ family of mountings also provides an unparalleled degree of protection for load cells and maintains a permanent load cell safety system, reducing load cell damage and plant down-time.

CellMate assemblies are available in four models with weighing capacities from 11 to 11,000 lbs (5 to 5000 kg) in stainless steel. Standard dimensions and hole sizes provide for fast and easy placement of load cells. Ideal for use with Tedea-Huntleigh's SafeGard™ line of hermetically sealed shear and bending beam load cells, CellMate™ enables users to install the fittings on silos or tanks with or without load cells.

**TEDEA** **th**  
**HUNTLEIGH**  
EXCELLENCE IN LOAD CELLS

# CellMate™

## Load Cell Mounting Assembly

### The Cellmate™ Advantage

Simple to install, CellMate's standard key dimensions make for easy design into new installations and easy fitting to existing vessels.

CellMate can be put in place with or without the load cell in position. Plant down-time is reduced and the risk of damage to the load cell is eliminated during installation. CellMate provides a permanent integral safety jacking system for your vessel.

Vessel movement due to thermal effects is accommodated with no loss of performance or accuracy by means of CellMate's built-in "free motion" load adaptor.

A substantial protection plate is correctly positioned above the gland to prevent damage by falling objects or misuse, e.g. as a convenient step point.

Pivot units having the same mounting dimensions as a complete CellMate and load cell, allow for the installation of lower accuracy systems.

All the CellMate advantages are retained and, if required at a later date, the pivot can be replaced by an active load cell unit with corresponding improvements in system performance.

Maximum lift off protection from the effects of wind or accidental collision is built-in.

When vessels being weighed are in hazardous areas, heavy duty ground straps ensure that no potential differences exist between upper and lower mounting plates. This low resistance path also assists in removing unwanted strong welding currents.

Base plates and top plates are cut from high grade stainless steels, providing a high degree of resistance to corrosion. Load bearing surfaces have a hardened finish and all fasteners are standard catalog items.

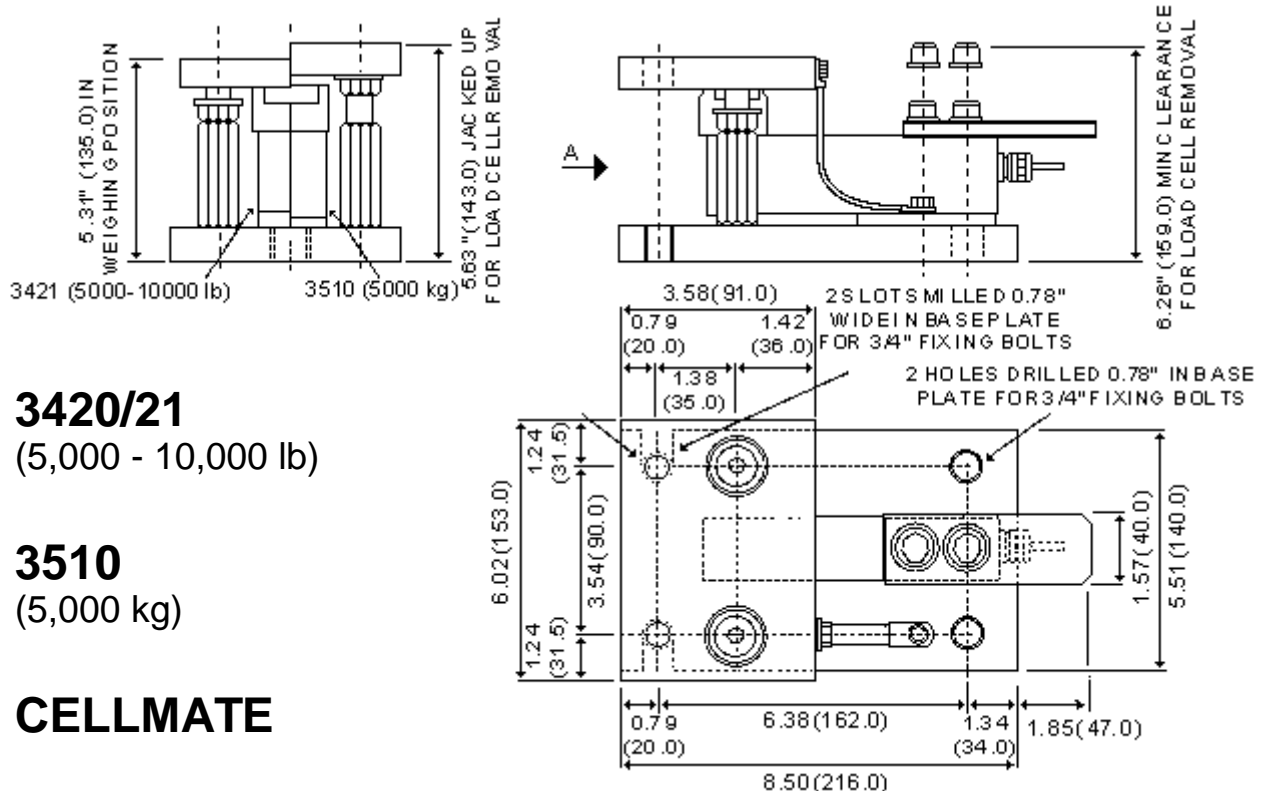

**3420/21**  
(5,000 - 10,000 lb)

**3510**  
(5,000 kg)

**CELLMATE**

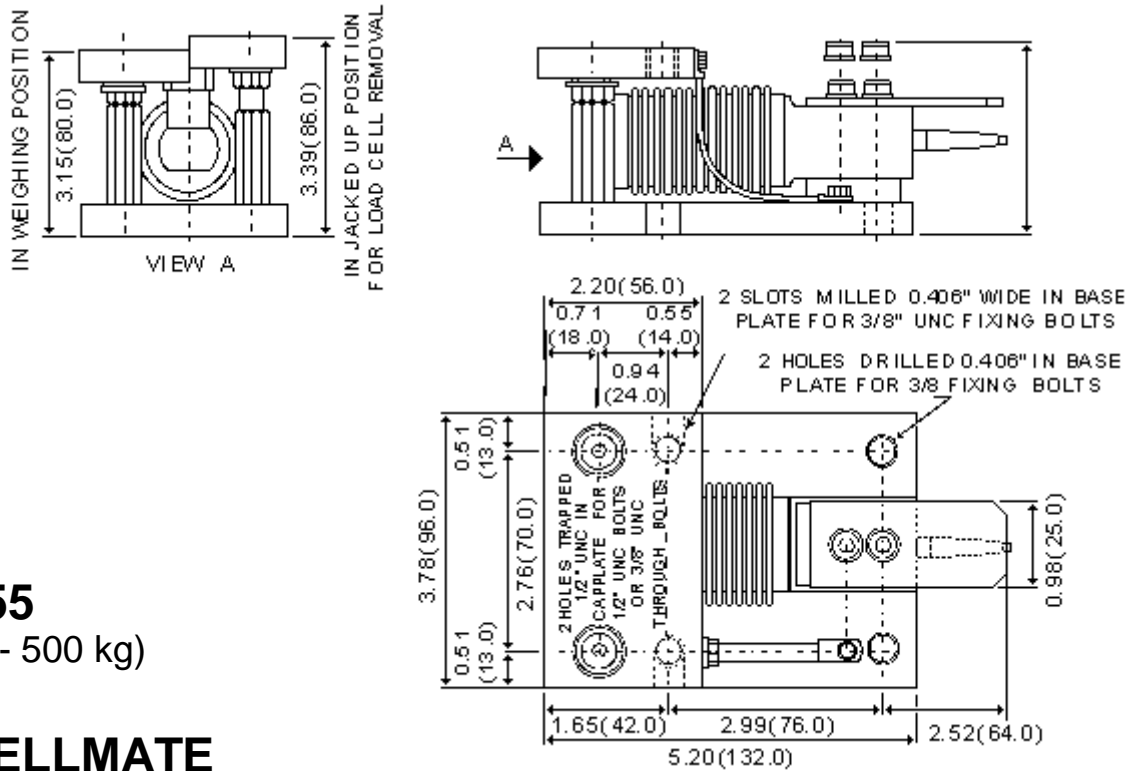
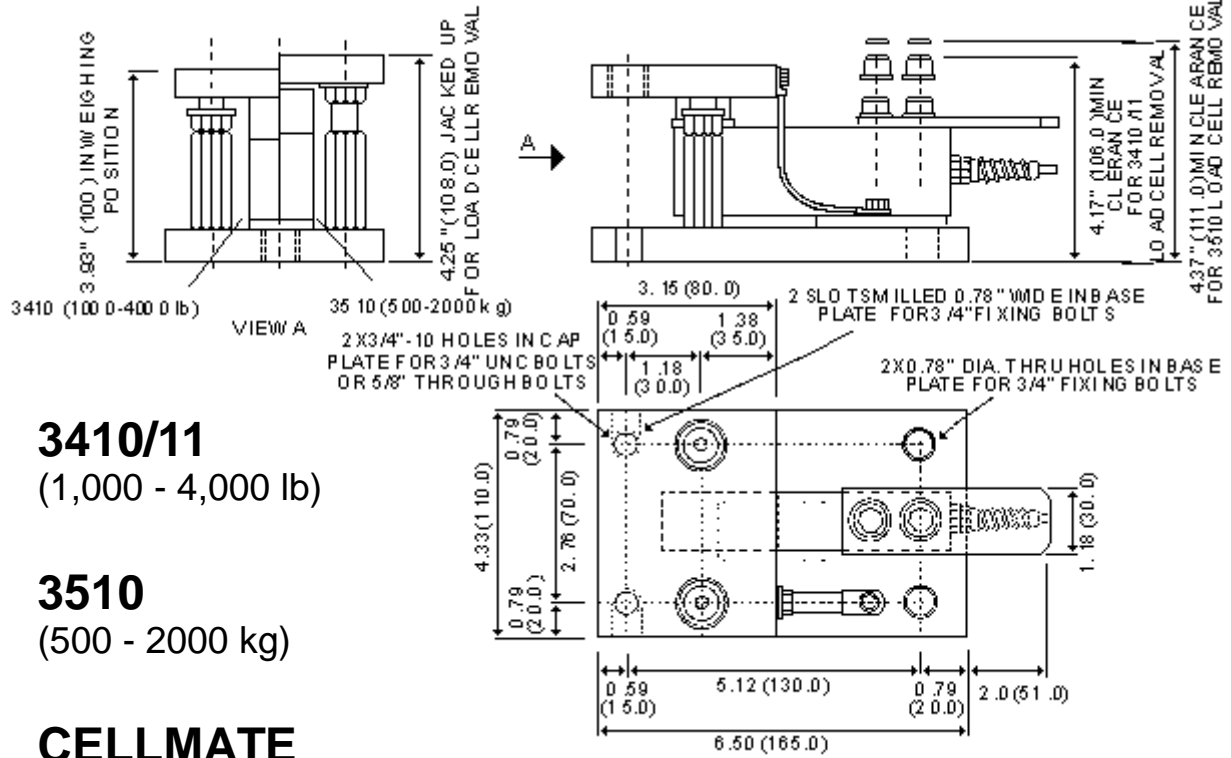

# CellMate™

## Load Cell Mounting Assembly

### Model 3510 (500 - 5,000 kg)

The 3510 is a hermetically sealed low profile stainless steel shear beam load cell. Its all welded construction and polyurethane sealed cable enables the 3510 to function in the harshest of environments.

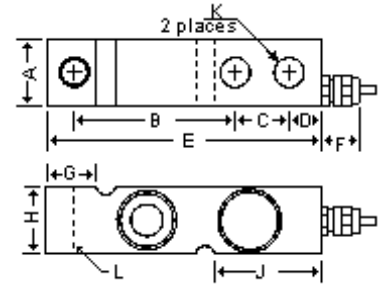

	A	B	C	D	E	F	G	H	J	K	L
500- 2000 kg	1.26 (32.0)	3 (76.2)	1 (25.4)	0.62 (15.8)	5.12 (130.1)	0.71 (18.03)	0.93 (23.6)	1.26 (32.0)	1.99 (50.5)	13.5 mm	M12 X 1.75
5000 kg	1.44 (36.6)	3.75 (95.3)	1.5 (38.1)	0.75 (19.1)	6.75 (171.5)	0.71 (18.0)	1.46 (37.1)	1.89 (48.0)	2.76 (70.0)	20.5 mm	20.5 mm

### Model 355 (5 - 500 kg)

The 355 is a bending beam load cell designed for low profile platforms, weighing the packing machines, conversion of mechanical scales, and a variety of other applications where sealed cells are required.

Fully welded, hermetically sealed, stainless steel construction assures long-term stability even under harsh environments and extreme temperatures; hermetically sealed to IP68 and OIML Class C4 approved.

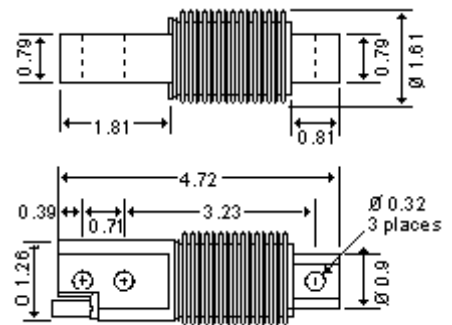

### NOTES:

All dimensions in inches (mm) unless otherwise noted.

All specifications are subject to change without notice.

### Model 3400 Series (1K to 10K lbs)

The 3400 Series is a highly accurate low cost shear beam load cell. Environmentally protected to IP67 it is Factory Mutual, NTEP and OIML Class C3 approved. Available in stainless steel or nickel plated tool steel.

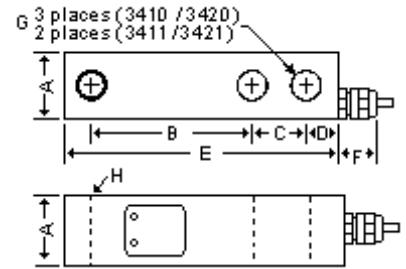

	A	B	C	D	E	F	G	H
<b>3410</b>	1.24	3.00	1.00	0.62	5.12	1.75	0.53	1/2 - 20 UNF
<b>3411</b>	(31.5)	(76.2)	(25.4)	(15.7)	(130.0)	(19.1)	(13.5)	X .60 min deep
<b>3420</b>	1.49	3.75	1.50	0.75	6.75	0.75	0.78	3/4 - 16 UNF
<b>3421</b>	(37.9)	(95.3)	(38.1)	(19.1)	(171.5)	(19.1)	(19.8)	X .75 min deep

### NOTES:

All dimensions in inches (mm) unless otherwise noted.

All specifications are subject to change without notice.