

Series 1003

Transducer Indicator

The Model 1003 Transducer Indicator provides complete electronic support to AC and DC LVDT's, or other DC powered transducers. The AC version provides an appropriate excitation voltage (at 3 or 7 kHz) for the LVDT and also demodulates the output, providing not only a digital readout, but a continuous analog output. This eliminates the need for a separate oscillator /demodulator. The DC version contains a dual power supply for transducers requiring both positive and negative excitation. Ideal for use in the lab or in a high speed closed loop system, this versatile indicator comes standard with a 5 digit L.E.D. readout to provide maximum resolution.



Key Features

Panel Mount Indicator
Supports AC and DC Transducers

Splashproof Front Panel
4 Independent Setpoints

Calibrating the unit is accomplished via membrane switches on the front panel, eliminating the need for internal trim pot adjustment. The user can calibrate the unit by simply entering the full scale endpoints, the zero position, and decimal point location. This allows a readout in inches, degrees, or other engineering units corresponding to the application. During the calibration, there are 6 user defined setpoints: two high, two low, and the high and low hysteresis points for the system. When the specified tolerances are exceeded, indicator lights are illuminated, providing a visual signal to the user. Optional relays, which correspond to the distinct set points, will add another

level of automation to the user's process. A tare function, which allows the meter to be zeroed anywhere along the transducer's travel, is standard. This feature can be used to measure the deviation from a standard within the working range of the sensor.

The Model 1003 features a continuous analog output for use as an input to a control process or A/D converter. Optional RS232C Serial output is offered for direct connection to PC based data acquisition systems, eliminating the need for external signal conditioning. All connectors necessary for indicator operation are provided, as well as a complete instruction manual.

INDICATOR SPECIFICATIONS

Dimensions	Inches (mm)	Temperature	
Case Size (H x W x L)	1.72 (44) x 3.56 (90) x 5.0 (127)	Operating	+31°F to 131°F (0°C to +55°C)
Front Panel (H x W x L)	1.91 (49) x 3.80 (97) x 0.1 (3)	Storage	-40°F to 185°F (-40°C to +86°C)
Cut Out (H x W)	1.77 (45) x 3.62 (92)	Coefficient of Sensitivity	±0.006%/°F Typical
Max. Panel Thickness	0.25 (6.35)	Coefficient of Zero	± 2 LSD maximum
Input		Display	
Supply Voltage	115 Vrms ±10%; 50/60 Hz (220 Vrms Optional)	Readout (red LED)	5 Digit; 0.4" high
Current	0.05A	Resolution	1 part in 20,000
		Accuracy	±0.01% Reading ±1 LSD
		Update	Once every 500 msec

SPECIFICATIONS

Supply Voltage to Transducer	1.7 Vrms \pm 4% into 100 Ohm Minimum	\pm 15 VDC \pm 5%; up to 30 mA
Max. Transducer Output	0.973 Vrms	\pm 13.2 VDC
Analog Output Voltage ¹	Adjustable to \pm 5.0 VDC with LVDT FS Output of .74 Vrms to .92 Vrms	Adjustable to \pm 5.0 VDC with LVDT FS Output of 2.9 VDC to 13.2 VDC
Frequency Response (nominal)	300 Hz	375 Hz
Noise and Ripple	< 2mVrms	
Stability	\pm 0.002%	

Notes: ¹Impedance < 2 Ohm; can operate into 1000 Ohm minimum without distortion. Short Circuit protected.

OPTIONS

RS232C		RELAYS	
Mode	Half Duplex Transmit Only	With RS232C	4 - N.O./ COM.
Baud Rate	1200 (Factory Set)	Without RS232C	4 - N.O./ COM./ N.C.
	(600 to 19,200 available)	Rating	250 Vrms @ 4 mA Max 30 VDC @ 3 mA Max
Handshake	DSR - Data Set Ready DTR - Data Terminal Ready DTX - Transmit Data Signal	Response Time	"on" approx. 8 msec. "off" approx. 5 msec
		Set Points	2 High; 2 Low
		Hysteresis Points	1 High; 1 Low

ORDERING INFORMATION

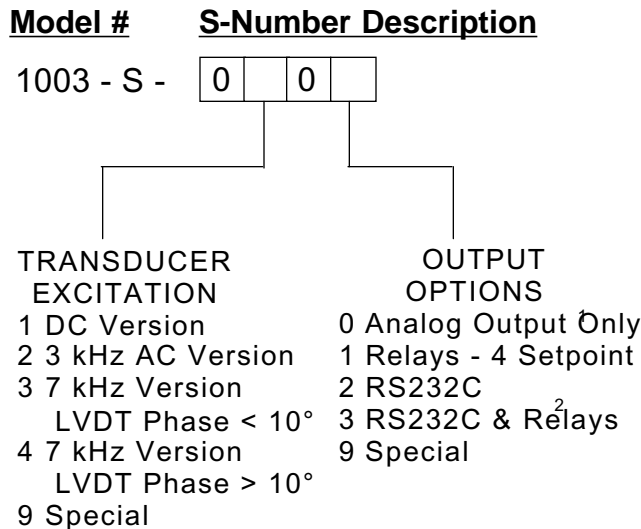

Notes: 1. Analog output provided as standard equipment on
2. The combination of the RS232C and Relays res
Relay configuration as described in the table ab