



# NOISE CONTROL IN STRAIN GAGE MEASUREMENTS

## Tech Note TN-501-2

### Introduction

Strain measurements must often be made in the presence of electric and/or magnetic fields which can superimpose electrical noise on the measurement signals. If not controlled, the noise can lead to inaccurate results and incorrect interpretation of the strain signals; and, in severe cases, can obscure the strain signals altogether. In order to control the noise level, and maximize the signal-to-noise ratio, it is necessary first to understand the types and characteristics of electrical noise, as well as the sources of such noise. With this understanding, it is then possible to apply the most effective noise-reduction measures to any particular instrumentation problem.

This technical note identifies some of the more common noise sources, and describes the routes by which the noise is induced into strain gage circuits. It should be noted that the treatment here is limited to noise from external electrical and magnetic sources. This note does not cover effects from nuclear or thermal sources, nor does it consider the effects of variable wiring or contact resistance caused by slip rings, connectors, switches, etc. Following the discussion of noise sources, specific methods are given, varying with the noise-coupling mechanism, for noise avoidance. The information in this technical note is equally applicable to both analog and digital systems employing dc amplifiers. It also applies to systems using carrier excitation and carrier amplifiers.

### Noise Sources and Pickup Media

Virtually every electrical device that generates, consumes, or transmits power is a potential source for causing noise in strain gage circuits. And, in general, the higher the voltage or current level, and the closer the strain gage circuit to the electrical device, the greater will be the induced noise. Following is a list of common electrical noise sources:

- ac power lines
- motors and motor starters
- transformers
- relays
- generators
- rotating and reciprocating machinery
- arc welders
- vibrators
- fluorescent lamps
- radio transmitters
- electrical storms
- soldering irons

Electrical noise from these sources can be categorized into two basic types: electrostatic and magnetic. The two types of noise are fundamentally different, and thus require

different noise-reduction measures. Unfortunately, most of the common noise sources listed produce combinations of the two noise types, which can complicate the noise-reduction problem.

Electrostatic fields are generated by the presence of voltage—with, or without current flow. Alternating electrical fields inject noise into strain gage systems through the phenomenon of *capacitive coupling*, by which charges of correspondingly alternating sign are developed on any electrical conductors subjected to the field (Figure 1). Fluorescent lighting is one of the more common sources of electrostatic noise.

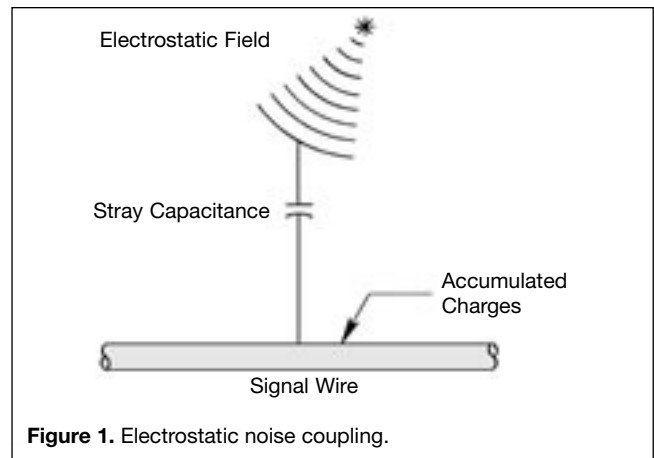

Figure 1. Electrostatic noise coupling.

Magnetic fields are ordinarily created either by the flow of electric current or by the presence of permanent magnetism. Motors and transformers are examples of the former, and the earth's magnetic field is an instance of the latter. In order for noise voltage (emf) to be developed in a conductor, magnetic lines of flux must be "cut" by the conductor. Electric generators function on this basic principle. In the presence of an alternating field, such as that surrounding a 50/60-Hz power line, voltage will be induced into any stationary conductor as the magnetic field expands and collapses (Figure 2). Similarly, a conductor moving through the earth's magnetic field has a noise voltage generated in it as it cuts the lines of flux. Since most irons and steels are ferromagnetic, moving machine members redirect existing lines of flux, and may cause them to be cut by adjacent sensitive conductors. As a result, signal conductors in the vicinity of moving or rotating machinery are generally subject to noise voltages from this source.

## Noise Control in Strain Gage Measurements

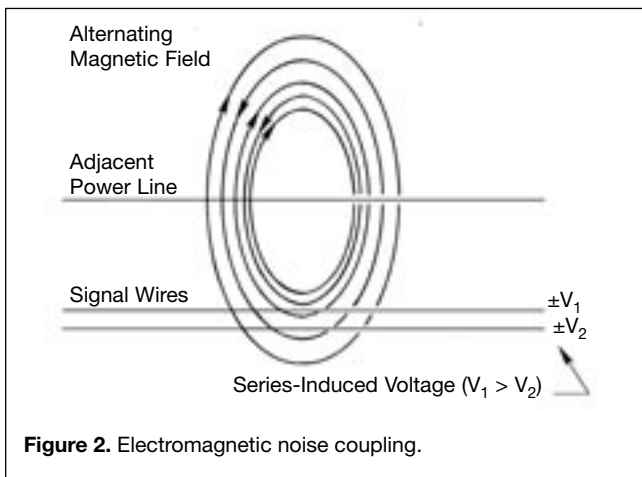

Figure 2. Electromagnetic noise coupling.

### Detecting and Troubleshooting

In order to effectively assess the presence and magnitude of noise, the strain gage instrument selected for use should incorporate a simple, but very significant feature—provision for removing the excitation from the Wheatstone bridge. With such a control, the instrument output can be easily checked for noise, independently of any strain signal. This represents a very powerful tool for evaluating the effectiveness of shields and grounding, and for experimentally modifying these methods to minimize the effects of noise. All Vishay Micro-Measurements strain gage instruments and data systems are equipped with this important feature.

The following procedure can be used to troubleshoot a system for noise:

1. If not already known, determine the tolerable levels of noise in output units (millivolts, inches of deflection, etc.) as observed on a readout such as an oscilloscope or data system display.
2. Consideration should be given first to noise sources affecting the measurement system, isolated from all external circuits. For this purpose, disconnect any strain gage leads, and terminate the S+/S- amplifier inputs with about the same input impedance that the amplifier normally senses (typically between 120 and 1000 ohms). If excessive noise exists:
  - a) Check for ground loops (more than one connection of the system to ground).
  - b) Check for line- (“mains-”) radiated noise.
  - c) If feasible, reduce amplifier gain and compensate by increasing bridge voltage.
3. Having eliminated or satisfactorily minimized noise pickup by the instrument, turn next to the external circuitry. With the excitation set to *off*, connect the gage or transducer circuit (including leadwires) to the instrument, and observe noise. Of course, any additional noise picked up in this step

is attributed to leadwire and/or gage pickup. If the output changes when the instrument chassis is touched with a finger, this is an indication of a poor ground and/or radio-frequency interference.

4. Apply a load to the part under test (with excitation still off). If additional noise is observed, the noise is due to something associated with the loading system such as a motor creating a magnetic field, or the motion of the gage or wiring (generating emf).
5. If possible, remove the load from the test part and apply excitation voltage to the bridge circuit. After balancing the bridge, any subsequent change in output, if gradual, is zero-shift, not noise. This may be due to gage self-heating effects (see Tech Note TN-502, *Strain Gage Excitation Levels*)—or other time-dependent resistance changes.

The following sections of this Tech Note give recommended noise-reduction procedures for electrostatic noise, and for magnetic noise.

### Electrostatic Noise Reduction

The simplest and most effective barrier against electrostatic noise pickup is a conductive shield, sometimes referred to as a *Faraday cage*. It functions by capturing the charges that would otherwise reach the signal wiring. Once collected, these charges must be drained off to a satisfactory ground (or reference potential). If not provided with a low-resistance drainage path, the charges can be coupled into the signal conductors through the shield-to-cable capacitance (Figure 3).

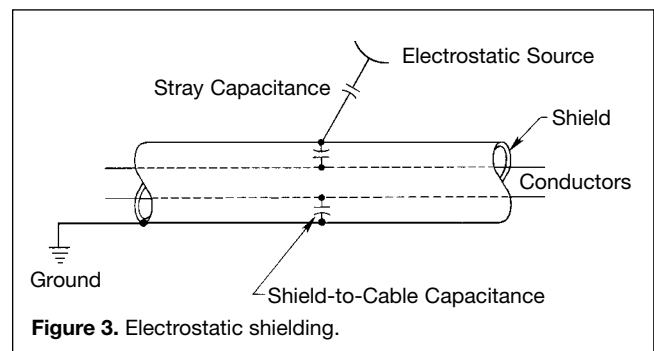

Figure 3. Electrostatic shielding.

The two most popular types of cable shields are braided wire and conductive foil. The braided-shield construction provides about 95 percent coverage of the cable, and is characteristically low in resistance. Although commonly higher in resistance, foil shields give 100 percent cable coverage, and are also easier to terminate. Following are commercially available examples of the two types of shielded cable:

- braided: Vishay Micro-Measurements Type 430-FST (four conductors, twisted)
- foil: Vishay Micro-Measurements Type 422-DSV

### Noise Control in Strain Gage Measurements

When long reaches of multiple conductors are run adjacent to each other, problems with crosstalk between conductors can be encountered. With runs of 50 feet [15 m] or more, significant levels of noise can be induced into sensitive conductors through both magnetic and electrostatic coupling. Even though bridge-excitation conductors may carry only a millivolt of noise, there can be significant coupling to signal conductors to produce potentially troublesome microvolt-level noise in those conductors. The noise transfer can be minimized by employing an instrumentation cable composed of individually shielded pairs—one pair for excitation, and one pair for the signal. This type of construction is embodied in Vishay Micro-Measurements Type 422-DSV cable. When using such cable (those having separate shields), both shields should be grounded at the same, usually instrument, end of the cable. Electromagnetic coupling between excitation and signal pairs can be reduced somewhat by using a cable that has its conductor pairs twisted on separate axes. Belden No. 8730 cable has the conductor pairs separately twisted, including one pair shielded with foil.

The shield-to-conductor capacitance can also become significant for long runs, since the capacitance is proportional to the cable length. Therefore, a significant portion of the residual noise can be coupled from even a well-grounded shield to the sensitive conductors. To minimize this effect, some strain gage instruments (for example, Vishay Micro-Measurements 2300 System) incorporate a feature called a *driven guard*. A driven guard (also known as a *driven shield*) functions by maintaining the shield at a voltage equal to the average signal, or common-mode voltage. Since, with this arrangement, the voltage difference between the conductors and shield is essentially zero, the effective capacitance is decreased, and there is minimal noise transfer. The result is a very quiet shield. It is important to note that, for proper operation, the driven shield is connected at only one end to the driven-guard pin on the instrument input connector. The driven shield is ordinarily surrounded by a second shield, which should be grounded at one end.

In a fully guarded amplifier system (for example, Vishay Micro-Measurements Model 2200 System), the common-mode voltage of the bridge excitation supply and the signal input terminals “float” to the level on the guard shield. Connecting the shield to the test structure or source of common-mode voltage at the gage installation site can provide very effective noise reduction since the voltage between signal conductors and the shield is minimized.

Another often-overlooked source of noise is leakage to ground through the strain gage and/or the cabling. If excessive, this leakage can cause noise transfer from the specimen to the gage circuit, since even supposedly well-grounded specimens may carry some noise. It is not uncommon to have strain gages installed on nominally grounded test objects that, in fact, have noise levels expressible in volts. And, of course, any strain gage installation on a conductive

specimen forms a classic capacitor which can couple noise from the specimen to the gage. In light of these considerations, it is always a good practice to make certain that the specimen is properly grounded and that leakage between the gage circuit and the specimen is well within bounds.

Prior to connecting leadwires to the strain gage, the insulation resistance from the gage to the specimen should be measured with a megohm meter such as the Vishay Micro-Measurements Model 1300 Gage Installation Tester. A reading of 10 000 megohms is normally considered a minimum for satisfactory system operation. Readings below this level are indicative of a possibly troublesome gage installation which can deteriorate with time and strain. It should also be kept in mind, for gage installations which will operate at elevated temperatures, that leakage resistance tends to decrease as the temperature increases.

After cable placement and connection at the gage-end of the cable, the following resistance measurements should be made, preferably from the instrument-end of the cable: conductor-to-ground, shield-to-ground, and conductor-to-shield. Because of distributed leakage, these resistances may be somewhat lower than the gage-to-specimen resistance; but cables with significantly lower resistances should be investigated, and the excessive leakage eliminated to avoid potential noise problems.

#### Electromagnetic Noise Reduction

The most effective approach to minimizing magnetically induced noise is not to attempt magnetic shielding of the sensitive conductors; but, instead, to ensure that noise voltages are induced equally in both sides of the amplifier input (Figure 4). When analyzed, all conventional strain gage bridge arrangements—quarter bridge (two- or three-leadwire), half bridge, and full bridge—reduce to the same basic circuit shown in Figure 4. This is also true for systems that employ the “rotated” or nonsymmetrical bridge circuit. Achievement of noise cancellation by the method shown in Figure 4 requires that the amplifier exhibit good common-mode rejection characteristics. Attention must also be given, however, to the strain gage wiring, and to the effects of nearby power lines. For example, it is evident from Figure 2 that a gradient in magnetic field intensity exists with respect

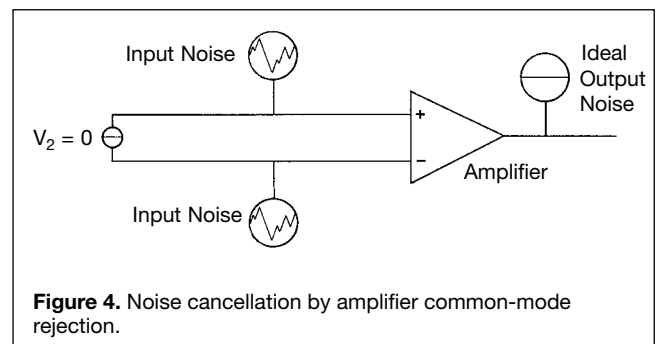

### Noise Control in Strain Gage Measurements

to distance from the current-carrying power line. The series noise voltages ( $V_1$  and  $V_2$ ) induced in the signal wires will therefore depend greatly upon their distances from the current-carrying conductors. Twisting the signal conductors together tends to make the distances equal, on the average, thereby inducing equal noise voltages which will cancel each other. Correspondingly effective, the magnetic field strengths radiated by power lines can be reduced by twisting the power conductors.

In theory, at least, the more twists per unit conductor length, the better. Standard twisted-conductor cables, such as Belden No. 8771, have sufficient twisting for most applications. However, in environments with high magnetic field gradients, such as those found close to motors, generators, and transformers, tighter twisting may be required. For particularly severe applications, conventional twisting may be inadequate, and it may be necessary to use a special woven cable as described later.

When attaching leadwires to a strain gage for operation in a magnetic field, connections should be made directly to the solder tabs on the gage, rather than through auxiliary terminals. Vishay Micro-Measurements CEA-Series gages, with copper-coated solder tabs, are particularly suited to this type of application. As shown in Figure 5, the gage selection and the wiring arrangements can greatly affect the sensitivity to magnetic pickup. It will be noticed that the preferred arrangement minimizes the susceptible loop area between the wires. For the same reason, flat ribbon cable is very prone to noise pickup, and its use in magnetic fields should be avoided. When necessary to use this type of cable, optimal conductor allocation, as shown in Figure 6, can help reduce the pickup. In addition, excess lengths of input cable should be eliminated; and under no circumstances should the extra length be disposed of by winding into a coil as illustrated in Figure 7a. If excess cable length cannot be avoided, it should be folded in half and coiled as indicated in Figure 7b so that each clockwise current loop is intimately accompanied by a counterclockwise loop. The same cabling considerations apply to both the excitation leads and the signal leads, and to power cables.

Unlike the case for electrostatic noise, a simple, grounded conductive shield does not function as a barrier to magnetic noise. Magnetic shields operate on a different principle, and serve to bend or shunt the magnetic field around the conductor rather than eliminate it. Magnetic shields are made from high-permeability materials such as iron and other ferro-magnetic metals. At the relatively low 50/60-Hz power line frequencies often encountered in magnetic noise problems, shield thicknesses (using common iron for example) on the order of 0.1 in [2.5 mm] are needed before significant noise reduction is achieved. Heavy-walled iron conduit can also be used to provide some reduction in magnetic noise

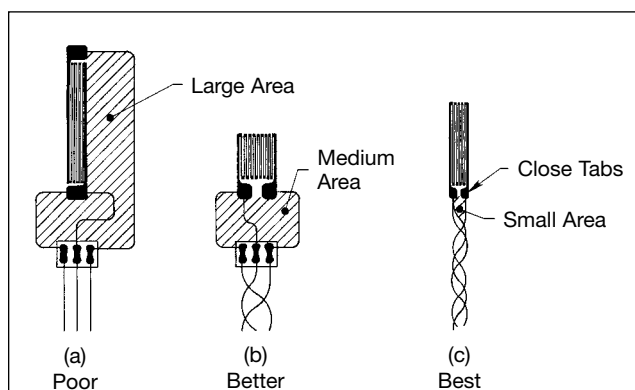

Figure 5. Gage selection and wiring technique.

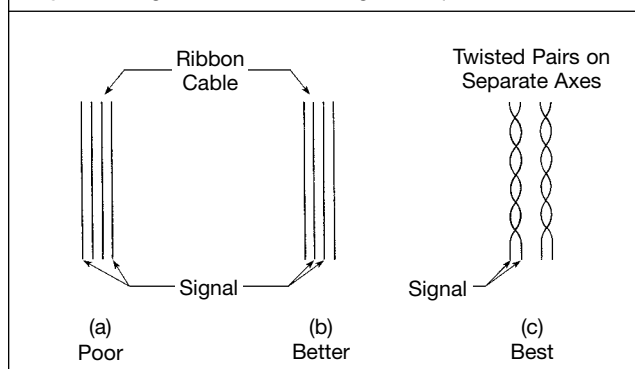

Figure 6. Cable comparison.

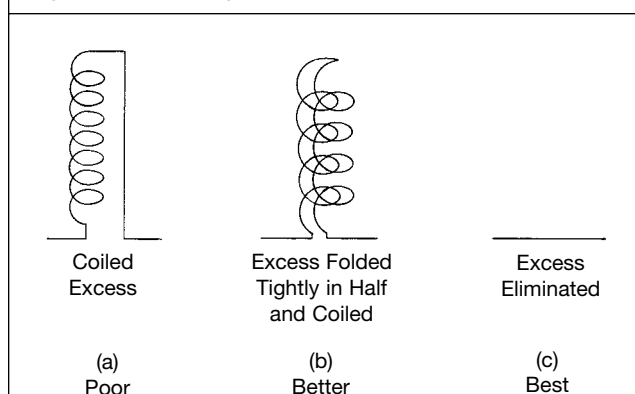

Figure 7. Handling excess cable.

pickup. However, there are special high-permeability alloys (mu-metal®, for instance) that have been developed specifically for magnetic shielding purposes. These are effective in much thinner shields than with iron. When faced with the apparent necessity for magnetic shielding, attention should always be given to reducing the noise at its source. As an example, transformers can readily be designed to minimize the leakage flux.

### Noise Control in Strain Gage Measurements

#### Severe Noise Environments

The preceding two sections have treated the standard methods of noise reduction applicable to the majority of instrumentation problems. This section describes techniques that may become necessary when very high noise levels are anticipated or experienced.

#### Electrostatic Fields

Generally, when shielding against audio-frequency electrostatic noise (below 20 kHz), it is not good practice to ground the shield at more than one point. The reason for this is that the ground points may be at different voltage levels, causing current to flow through the shield. Current flow in such *ground loops* can induce noise in the signal-carrying conductors through the same phenomenon that occurs in a transformer.

However, for long cables in severe noise environments, the shield impedance from one end to the other can become significant, particularly with high-frequency noise sources. When this occurs, the noise charges captured by the shield no longer find a low-resistance drain to ground, and the result is a noisy shield. Improved shield performance under such circumstances can often be obtained by grounding the shield at both ends, and/or at intermediate points—preferably at points near any localized sources of electrostatic noise. Multiple-point ground connections may also be necessary when radio-frequency interference (RFI) problems are encountered. At these frequencies the shield, or segments of the shield between grounded points, can display antenna behavior. By experimentally grounding the shield at numerous points along its length, the optimum grounding scheme can be determined.

Although the leadwires are ordinarily the dominant medium for noise induction in a strain gage circuit, noise pickup can also occur in the gage itself. When needed, a simple electrostatic shield can be fabricated by forming an aluminum-foil box over the gage and the unshielded leadwire terminations. If the gaged specimen is small and electrically conductive, aluminum tape with conductive adhesive should be used to connect the cable shield, the gage shield, and the specimen together. Conductive epoxy compounds can also be used for this purpose.

On the other hand, when gages are installed on machinery or other large, conductive test objects, care must be exercised to prevent the occurrence of ground current loops in the shield. In such cases, the foil should be electrically insulated from the machine. But the machine should be grounded with a heavy-gauge copper wire (at least 14 gauge or heavier depending upon application) connected to the single-point ground near the instrument. Care must also be taken to make certain that the shield does not form a short circuit to the gage wiring. If the cable has two shields, then, ideally at least, a double-foil

shield should be used over the strain gage. The two shields should be connected together only at the instrument end of the cable.

A word about ground connections is in order. It is important to remember that all conductors are characterized by resistance, inductance, and shunt capacitance. As a result, attention should always be given to the quality of the ground connections. To be effective, a connection to ground should be made with heavy-gauge copper wire, and should be as short as practicable. If the nearest earth ground is too remote, a 6-ft [2-m] copper rod can be driven into the earth to establish a local ground.

#### Electromagnetic Fields

As with electrostatic noise pickup, the leadwires commonly represent the principal source of magnetic noise induction in strain gage circuits. In intense electromagnetic fields with steep gradients (near motors, generators, and similar equipment), ordinary wire-twisting techniques may prove inadequate. An end view of a conventionally twisted pair can reveal the reason for pickup. As indicated in Figure 4, even if the induced noise were precisely equal in both wires, the amplifier noise output would be zero only if the amplifier had infinite common-mode rejection characteristics—an impossibility. In order to minimize common-mode noise voltages, a special, woven, four-wire cable has been designed that, as seen from the wire end, eliminates the spiral inductive loops (Figure 8). For maximum cancellation of electrostatic fields, pairs of wires (composed of one wire from each plane) are connected in parallel. Referring to the figure, wires 1 and 2 are paralleled to form one conductor; and wires 3 and 4 to form the other. So connected, this type of cable is largely insensitive to magnetic field gradients, both parallel and perpendicular to the cable length. The cable is known as *Inter-8 Weave*, and is available from: Magnetic Shield Corp., 740 N. Thomas Drive, Bensenville, Illinois 60106.

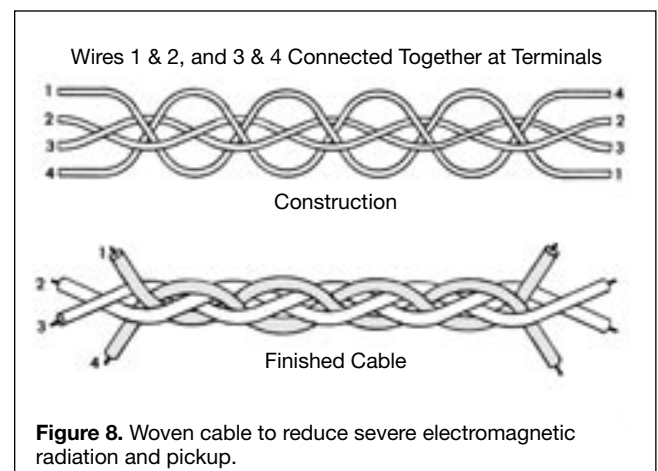

## Noise Control in Strain Gage Measurements

Even though the strain gage is much less frequently the significant medium for magnetic noise induction than the leadwires, different gage patterns have differing sensitivities to noise pickup. For instance, if the gage has both solder tabs at one end, the net noise pickup is less than for a gage with one tab at each end. As shown in Figure 5, the difference in noise sensitivity results from the relative size of the inductive loop area in each case. It is also worth noting that smaller gages, with more closely spaced grid lines, are intrinsically quieter than large gages.

In severe magnetic fields, especially those with steep gradients in field intensity, additional measures may be required. For this purpose, Vishay Micro-Measurements has developed a special gage configuration, the H-Series, consisting of two identical grids, with one stacked directly above, and insulated from, the other. By connecting the upper and lower gage elements in series so that the current flows in opposite directions through the two grids, the noise induced in the assembly tends to be self-cancelling. This arrangement is particularly effective against magnetic field gradients and their components parallel to the test surface. The dual-element gage is intended to function as one arm of a Wheatstone bridge circuit; and the bridge is usually completed with another gage of the same type, or with a fixed precision resistor. Standard practices are followed when installing the gages; but the Vishay Micro-Measurements M-Bond 600/610 adhesive system is recommended for bonding, since this will result in the thinnest glueline, and placement of the grids as close as possible to the specimen surface. Available from Vishay Micro-Measurements are two types of dual-element, noninductive stacked gages—linear H06A-AC1-125-700 and a three-gage rosette H06A-AD3-125-700. See Catalog 500 for details.

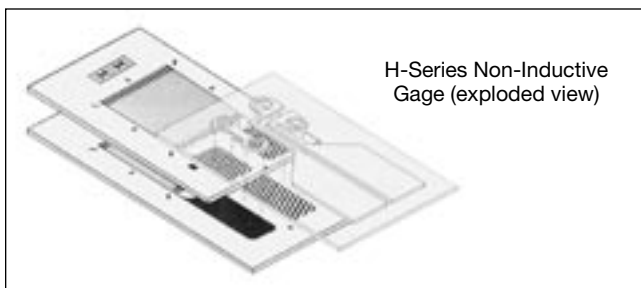

In addition to the strain gage size and pattern, the selection of the gage grid alloy should be given careful consideration. If the grid alloy is magnetic, it will be subject to extraneous physical forces in a magnetic field; and, if magnetoresistive, will undergo spurious resistance changes. Similarly, if the alloy is magnetostrictive, the grid will try to change length in the magnetic field. Isoelastic alloy, for example, should not be used in magnetic fields, since it is both strongly magnetoresistive and magnetostrictive. Stemming from their comparative freedom from mag-

netic effects, constantan and Karma-type alloys are usually selected for such applications. Constantan, however, at cryogenic temperatures and in high magnetic fields (7-70 Tesla) becomes severely magnetoresistive. The Karma-type alloy is ordinarily preferred for cryogenic service because of its generally superior performance in magnetic fields at very low temperatures.

When necessary, strain gages can also be shielded from electromagnetic fields to some degree with a magnetic shielding material such as mu-metal. Two or more layers of the shielding material may be required to effect a noticeable improvement. Of course, even this will be ineffective if the source of the magnetic field is beneath the strain gage. When high-frequency fields are encountered, be sure that the material is suitable (high permeability) at the anticipated frequency.

### Suggested Additional Reading

Coffee, M.B., "Common-mode Rejection Techniques for Low-Level Data Acquisition." *Instrumentation Technology* **24**, No. 7: 45-49 (1977).

Ficchi, R.F., *Practical Design for Electromagnetic Compatibility*. New York: Hayden Book Company, 1971.

Freyrik, H.S., et. al., "Nickel-Chromium Strain Gages for Cryogenic Stress Analysis of Super-Conducting Structures in High Magnetic Fields." *Proceedings of the Seventh Symposium on Engineering Problems of Fusion Research*, October, 1977.

Hayt, W.H., Jr., *Engineering Electromagnetics*. New York: McGraw-Hill Book Company, 1967.

Klipec, B.E., "How to Avoid Noise Pickup on Wire and Cable." *Instruments & Control Systems* **50**, No. 12: 27-30 (1977).

Krigman, Alan, "Sound and Fury: The Persistent Problem of Electrical Noise." *In-Tech* **32**, No. 1: 9-20 (1985). (Extensive bibliography).

McDermott, Jim, "EMI Shielding and Protective Components." *EDN* **24**, No. 16: 165-176 (1979).

Morrison, Ralph, *Grounding and Shielding Techniques in Instrumentation*, 2nd Ed. New York: John Wiley & Sons, Inc., 1977.

Severinsen, J., "Gaskets that Block EMI." *Machine Design* **47**, No. 19: 74-77 (1975).

Sitter, R.P., "RFI — What It Is and How to Control It, Part II: Reduction of Interference." *Instrumentation Technology* **25**, No. 10: 59-65 (1978).

\*Stein, Peter K., "Spurious Signals Generated in Strain Gages, Thermocouples and Leads." *LflMSE Publication No. 69*, April 1977.



## Noise Control in Strain Gage Measurements

\*Stein, Peter K., "The Response of Transducers to Their Environment, The Problem of Signal and Noise." *Lf/MSE Publication No. 17*, October 1969.

"Strain Gages Operate in 50 000-Gauss Magnetic Fields For Fusion Research." *Epsilonics* (published by Vishay Measurements Group, Inc.) **II**, No. 3: 4 (1982).

White, D.R.J., *Electromagnetic Interference and Compatibility*, **Vol. 3**, Germantown, Maryland: Don White Consultants, 1973.

\*Available from: Stein Engineering Services, 5602 E. Monte Rosa, Phoenix, Arizona 85018.



**INTERTECHNOLOGY**

1 Scarsdale Road, Don Mills, ON M3B 2R2

Tel: 416-445-5500 Fax: 416-445-1170

**TOLL FREE: 1-800-465-1600**

E-Mail: [sales@intertechnology.com](mailto:sales@intertechnology.com)

Website: [www.intertechnology.com](http://www.intertechnology.com)