



DESIGN CONSIDERATIONS FOR DIAPHRAGM PRESSURE TRANSDUCERS

Tech Note TN-510-1

The following notes are intended only as general guidance for the preliminary design of diaphragm pressure transducers. The actual design and development process involves arriving at the best compromise (relative to the performance specifications) of sensitivity, linearity, and frequency response, as determined primarily by the diaphragm diameter and thickness.

The formulas included here are based upon the following assumptions:

- Uniform diaphragm thickness
- Small deflections
- Infinitely rigid clamping around the diaphragm periphery
- Perfectly elastic behavior
- Negligible stiffening and mass effects due to the presence of the strain gage on the diaphragm.

To the degree that the actual transducer fails to satisfy all of the above assumptions, the formulas will be inaccurate. Because of this, the formulas should be used only in the initial stages of transducer development to determine the approximate proportions of the transducer.

Sensitivity

The strain distribution in a rigidly clamped diaphragm under uniform pressure distribution is shown in Figure 1.

The radial and tangential strains at the center of the diaphragm are identical, and expressed by:

$$\epsilon_{R_c} = \epsilon_{T_c} = \frac{3PR_o^2(1-\nu^2)}{8t^2E} \quad (1)$$

where:

	U.S. Customary Units	Metric (SI) Units
P = Pressure	psi	Pa
R_o = Diaphragm	in	mm
t = Diaphragm thickness	in	mm
ν = Poisson's ratio	dimensionless	
E = Modulus of elasticity	psi	Pa

The radial strain decreases rapidly as the radius increases, becoming negative, and (at the edge) equal to twice the

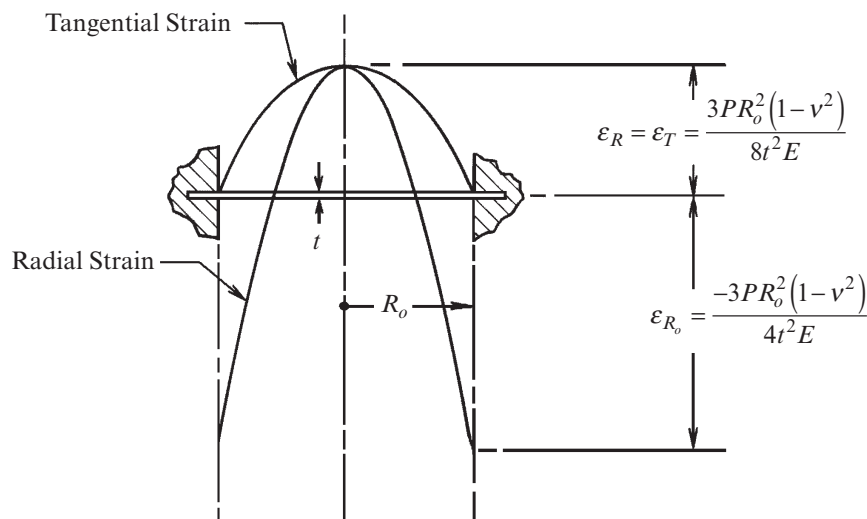

Fig.1 – Strain distribution in clamped diaphragm

Design Considerations for Diaphragm Pressure Transducers

center strain. The tangential strain decreases to zero at the periphery of the diaphragm. Thus,

$$\varepsilon_{R_o} = -\frac{3PR_o^2(1-\nu^2)}{4t^2E} \quad (2)$$

$$\varepsilon_{T_o} = 0 \quad (3)$$

Diaphragm Strain Gages

Vishay Micro-Measurements manufactures two different strain gage configurations (Figure 2a and b) for use on diaphragm pressure transducers.

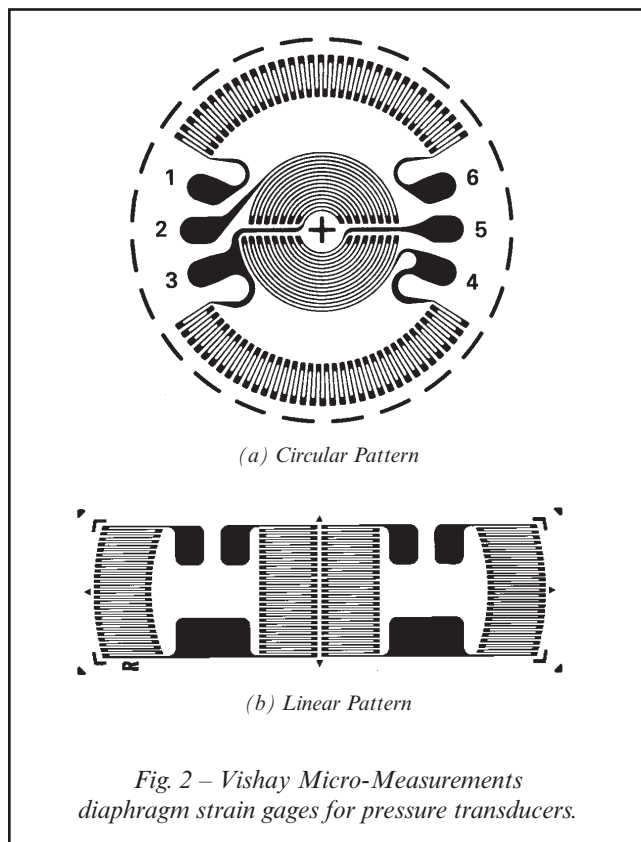

Fig. 2 – Vishay Micro-Measurements diaphragm strain gages for pressure transducers.

The traditional circular pattern as shown in Figure 2a has been designed to take advantage of the orientation of the tangential and radial strain fields described above. Taking account of the sign difference in the strains sensed by the radial and tangential grid elements, and dividing the elements into symmetrical pairs, permits incorporating a full bridge into a single strain gage. In terms of optimizing the strain gage design, the solder tabs have been located in a region of low strain.

The linear gage configuration shown in Figure 2b functions in the same manner as the circular version with only minor differences in total gage output (e_o)¹. The main advantages of using a linear design are ease of installation (less surface area to bond) and generally lower gage cost.

For either the circular or linear patterns, averaging the strain over the region covered by each sensing element (assuming a gage factor of 2.0), and averaging the outputs of all sensing elements, the total gage output (e_o) in millivolts per volt can be expressed approximately by the following formula:

$$e_o = 0.75 \frac{PR_o^2(1-\nu^2)}{t^2E} \times 10^3, \text{ mV/V} \quad (4)$$

Linearity

The preceding equations for diaphragm strain and output indicate that the output is proportional to the applied pressure. This precise linearity applies, however, only for vanishingly small deflections. In the case of finite deflections, the diaphragm pressure transducer is inherently nonlinear, and becomes more so, as deflection increases. As a general rule, the deflection of the diaphragm at the center must be no greater than the diaphragm thickness; and, for linearity in the order of 0.3%, should be limited to one quarter the diaphragm thickness.

Following is the formula for diaphragm deflection, based upon small-deflection theory:

$$Y_c = \frac{3PR_o^4(1-\nu^2)}{16t^3E} \quad (5)$$

where: Y_c = Center deflection, in (mm)

Frequency Response

In order to faithfully respond to dynamic pressures, the resonant frequency of the diaphragm must be considerably higher than the highest applied frequency. Depending strongly upon the degree of damping in the diaphragm strain gage assembly and in the fluid in contact with the diaphragm, the resonant frequency should be at least three to five times as high as the highest applied frequency. The subject of proper design for accurate dynamic response is too complex and extensive to be included here. However, for transducers subject to high frequencies or to sharp pressure wave fronts involving high-frequency components, careful consideration must be given to frequency response, both in terms of amplitude and phase-shift.

For reference purposes only, and subject to the assumptions listed earlier, the undamped resonant frequency of

Design Considerations for Diaphragm Pressure Transducers

a rigidly clamped diaphragm can be expressed using U.S. Customary Units as follows:

$$f_n = \frac{0.469t}{R_o^2} \sqrt{\frac{gE}{\gamma(1-\nu^2)}}, \text{ Hz} \quad (6)$$

where: g = Acceleration of gravity, 386.4 in/sec²
 γ = Weight density, lbs/in³

Since in the metric system (SI), density is derived without the effect of gravity, Equation (6) must be slightly modified when using SI Units as follows:

$$f_n = \frac{0.469t}{R_o^2} \sqrt{\frac{E}{\rho(1-\nu^2)}}, \text{ Hz} \quad (7)$$

where: ρ = Mass density, g/cm³

Construction

For maximum accuracy and minimum hysteresis, it is common practice to design pressure transducers so that the diaphragm is an integral part of the transducer body (Figure 3).

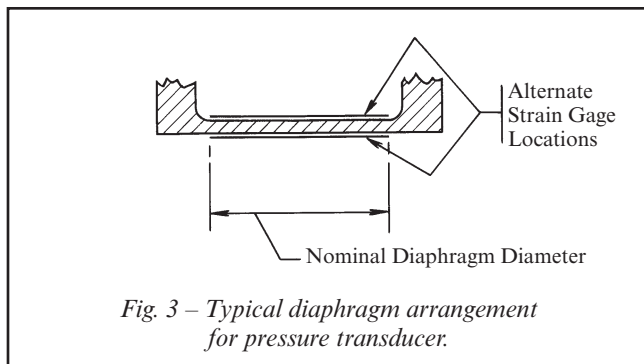

It is neither necessary nor desirable to try to machine the body of the transducer to a sharp internal corner at the junction with the diaphragm. The presence of the fillet radius, however, is merely one of the ways in which practical transducer construction differs from the idealized concept corresponding to the earlier assumptions and the equations given here. Because of this and the other differences, the transducer behavior will necessarily differ from the ideal; and experimental development will obviously be required to optimize the performance of a particular transducer.

Wiring

As shown in Figure 4a, the internal circuit of the circular pattern strain gage has two adjacent corners of the full bridge left open. The open bridge corners are left for the introduction of zero-shift versus temperature correction, and subsequent restoration of zero balance. The linear pattern (Figure 4b) has a slightly different circuit arrangement but the purpose is the same.

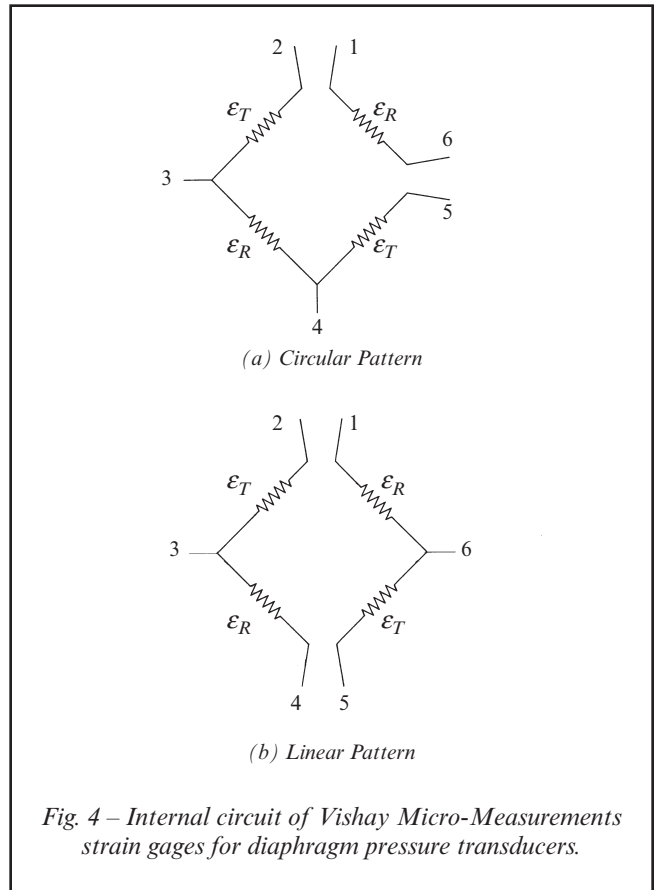

NOTE: See Vishay Micro-Measurements Catalogs 500 and TC-116 for circular pattern strain gages, and Catalog TC-116 for linear pattern strain gages for pressure transducers.

References

1. For a more detailed analysis of circular versus linear diaphragm strain gages, request a copy of *Influence of Grid Geometry on the Output of Strain-Gage-Based Diaphragm Pressure Transducers* by R.B. Watson (available from Vishay Micro-Measurements).

Design Considerations for Diaphragm Pressure Transducers
NUMERICAL EXAMPLE - U.S. Customary and Metric (SI) Units

Assume that a diaphragm pressure transducer is to be designed for a maximum rated pressure of 1000 psi [6.89 MPa], under which pressure the output (e_o) from a steel diaphragm should be 2 mV/V. If the diaphragm diameter is to be 0.670 in [17.02 mm], find the following:

- | | |
|-------------------------|--|
| (a) Diaphragm thickness | (c) Resonant Frequency |
| (b) Center deflection | (d) Approximate maximum diaphragm strain level |

CONSTANTS*

U.S. Customary		Metric (SI)	
$P = 1000 \text{ lbs/in}^2$	$\gamma = 0.283 \text{ lbs/in}^3$	$P = 6.89 \text{ MPa}$	$R_o = 8.51 \text{ mm} = 8.51 \times 10^{-3} \text{ m}$
$E = 30 \times 10^6 \text{ psi}$	$g = 386.4 \text{ in/sec}^2$	$\nu = 0.285$	$e_o = 2 \text{ mV/V} = 2 \times 10^{-3} \text{ V/V}$
$R_o = 0.335 \text{ in}$	$e_o = 2 \text{ mV/V} = 2 \times 10^{-3} \text{ V/V}$	$E = 207 \text{ GPa}$	$\rho = 7.83 \text{ g/cm}^3 = 7.83 \times 10^3 \text{ kg/m}^3$
$\nu = 0.285$			

- (a) From Eq. (4), solve for t , with e_o in units of V/V

$$t = \sqrt{\frac{0.75 PR_o^2(1-\nu^2)}{e_o E}}$$

$$t = \sqrt{\frac{0.75 \times 1000 \times (0.335)^2 [1 - (0.285)^2]}{(2 \times 10^{-3}) \times (30 \times 10^6)}}$$

$$t = 0.036 \text{ in}$$

$$t = \sqrt{\frac{0.75 \times (6.89 \times 10^6) \times (8.51 \times 10^{-3})^2 [1 - (0.285)^2]}{(2 \times 10^{-3}) \times (207 \times 10^9)}}$$

$$t = 9.11 \times 10^{-4} \text{ m} = 0.911 \text{ mm}$$

- (b) From Eq. (5),

$$Y_c = \frac{3PR_o^4(1-\nu^2)}{16t^3E}$$

$$Y_c = \frac{3 \times 1000 \times (0.335)^4 [1 - (0.285)^2]}{16 \times (0.036)^3 \times (30 \times 10^6)}$$

$$Y_c = 0.0016 \text{ in}$$

$$Y_c = \frac{3 \times (6.89 \times 10^6) \times (8.51 \times 10^{-3})^4 [1 - (0.285)^2]}{16 - (9.11 \times 10^{-4})^3 \times (207 \times 10^9)}$$

$$Y_c = 3.98 \times 10^{-5} \text{ m} = 0.0398 \text{ mm}$$

- (c) From Eq. (6),

$$f_n = \frac{0.469t}{R_o^2} \sqrt{\frac{gE}{\gamma(1-\nu^2)}}$$

$$f_n = \frac{0.469 \times 0.036}{(0.335)^2} \sqrt{\frac{386.4 \times (30 \times 10^6)}{0.283 [1 - (0.285)^2]}}$$

$$f_n = 31\,766 \text{ Hz}$$

- From Eq. (7),

$$f_n = \frac{0.469t}{R_o^2} \sqrt{\frac{gE}{\rho(1-\nu^2)}}$$

$$f_n = \frac{0.469 \times (9.11 \times 10^{-4})}{(8.51 \times 10^{-3})^2} \sqrt{\frac{207 \times 10^9}{7.83 \times 10^3 [1 - (0.285)^2]}}$$

$$f_n = 31\,647 \text{ Hz}$$



Design Considerations for Diaphragm Pressure Transducers
NUMERICAL EXAMPLE - U.S. Customary and Metric (SI) Units

(d) From Eq. (2),

$$\epsilon_{R_o} = -\frac{3PR_o^2(1-\nu^2)}{4t^2E}$$

$$\epsilon_{R_o} = -\frac{3 \times 1000 \times (0.335)^2 [1 - (0.285)^2]}{4 \times (0.036)^2 \times (30 \times 10^6)}$$

$$\epsilon_{R_o} = -1989 \mu\text{in/in}$$

$$\epsilon_{R_o} = -\frac{3 \times (6.89 \times 10^6) \times (8.51 \times 10^{-3})^2 [1 - (0.285)^2]}{4 \times (9.11 \times 10^{-4})^2 \times (207 \times 10^9)}$$

$$\epsilon_{R_o} = -2001 \mu\text{m/m}$$

**The small differences occurring in comparable U.S. Customary and Metric results arise from rounding numbers in both sets of calculations.*



INTERTECHNOLOGY

1 Scarsdale Road, Don Mills, ON M3B 2R2

Tel: 416-445-5500 Fax: 416-445-1170

TOLL FREE: 1-800-465-1600

E-Mail: sales@intertechnology.com

Website: www.intertechnology.com