



ERRORS DUE TO MISALIGNMENT OF STRAIN GAGES

Tech Note TN-511

Single Gage in a Uniform Biaxial Strain Field

When a gage is bonded to a test surface at a small angular error with respect to the intended axis of strain measurement, the indicated strain will also be in error due to the gage misalignment. In general, for a single gage in a uniform biaxial strain field, the magnitude of the misalignment error depends upon three factors (ignoring transverse sensitivity):

1. The ratio of the algebraic maximum to the algebraic minimum principal strain, ϵ_p/ϵ_q .
2. The angle ϕ between the maximum principal strain axis and the intended axis of strain measurements.
3. The angular mounting error, β , between the gage axis after bonding and the intended axis of strain measurement.

These quantities are defined in Figures 1 and 2 for the particular but common case of the uniaxial stress field. Figure 1 is a polar diagram of strain at the point in question, and Figure 2 gives the concentric Mohr's circles for stress and strain for the same point. In Figure 1, the distance to the boundary of the diagram along any radial line is proportional to the normal strain along the same line. The small lobes along Y axis in the diagram represent the negative

Poisson strain for this case. It can be seen qualitatively from Figure 1 that when ϕ is 0° or 90° , a small angular misalignment of the gage will produce a very small error in the strain indication, since the polar strain diagram is relatively flat and passing through zero-slope at these points.

However, for angles between 0° and 90° , Figure 1 shows that the error in indicated strain due to a small angular misalignment can be surprisingly large because the slope of the polar strain diagram is very steep in these regions. More specifically, it can be noticed from Figure 2 (on page 2), when $\phi = 45^\circ$, or $2\phi = 90^\circ$, that the same small angular misalignment will produce the maximum error in indicated strain, since ϵ is changing most rapidly with angle at this point. The same result could be obtained by writing the analytical expression for the polar strain diagram, and setting the second derivative equal to zero to solve for the angle at which the maximum slope occurs. In fact, the general statement can be made that in any uniform biaxial strain field the error due to gage misalignment is always greatest when measuring strain at 45° to a principal axis, and is always least when measuring the principal strains.* The error in strain

* The exception to this statement is the singular case when $\epsilon_p \equiv \epsilon_q$, as on the surface of a pressurized sphere. In this instance, the strain is everywhere the same and independent of directions.

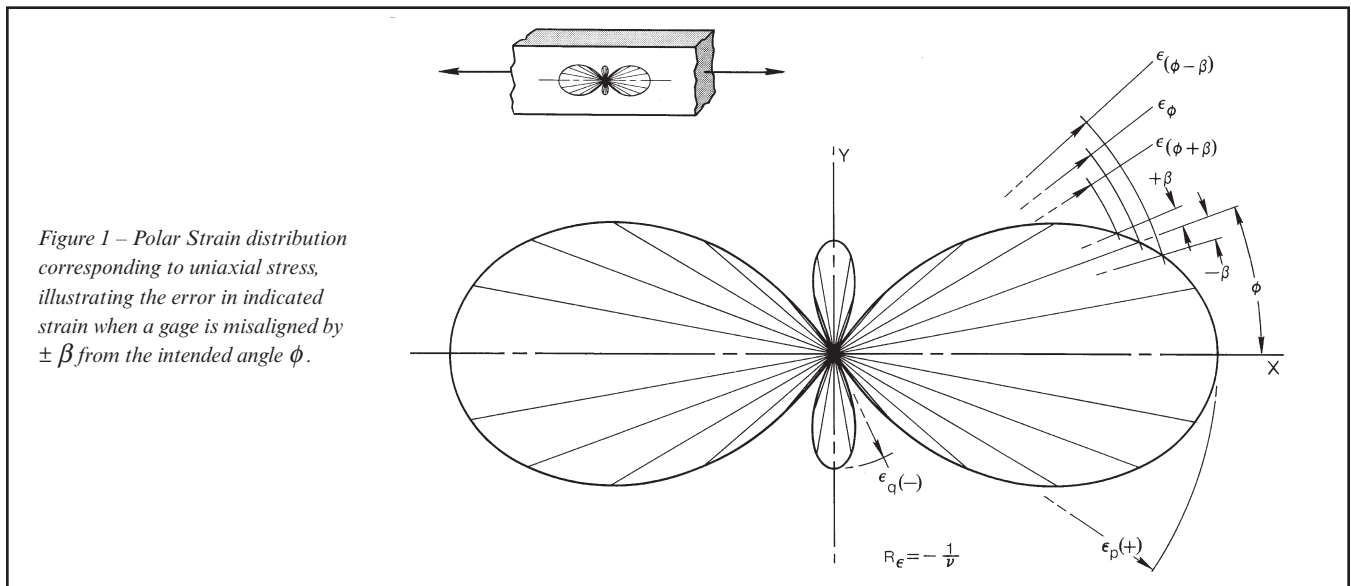
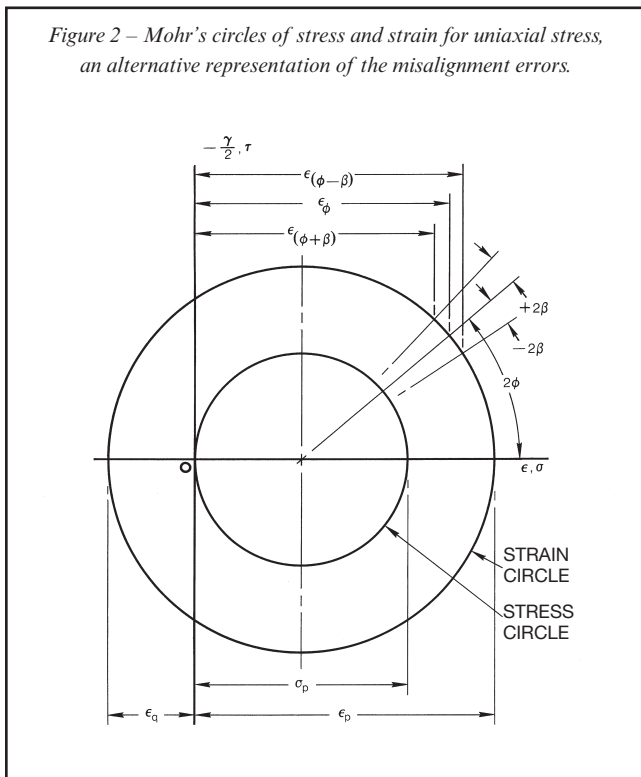

Figure 1 – Polar Strain distribution corresponding to uniaxial stress, illustrating the error in indicated strain when a gage is misaligned by $\pm \beta$ from the intended angle ϕ .

Errors Due to Misalignment of Strain Gages

Figure 2 – Mohr's circles of stress and strain for uniaxial stress, an alternative representation of the misalignment errors.



indication due to angular misalignment of the gage can be expressed as follows:

$$n = \epsilon_{(\phi \pm \beta)} - \epsilon_{\phi} \quad (1)$$

where: $n = \text{Error, } \mu\epsilon$

$\epsilon_{\phi} = \text{Strain along axis of intended measurement at angle } \phi \text{ from principal axis, } \mu\epsilon$

$\epsilon_{(\phi \pm \beta)} = \text{Strain along gage axis with angular mounting error of } \pm \beta, \mu\epsilon$

Or,

$$n = \frac{\epsilon_p - \epsilon_q}{2} [\cos 2(\phi \pm \beta) - \cos 2\phi] \quad (2)$$

where:

$\epsilon_p, \epsilon_q = \text{Maximum and minimum principal strains, respectively}$

The error can also be expressed as a percentage of the intended strain measurement, ϵ_{ϕ} :

$$n' = \frac{\epsilon_{(\phi \pm \beta)} - \epsilon_{\phi}}{\epsilon_{\phi}} \times 100 \quad (3)$$

$$n' = \frac{\cos 2(\phi \pm \beta) - \cos 2\phi}{\frac{R_{\epsilon} + 1}{R_{\epsilon} - 1} + \cos 2\phi} \times 100 \quad (4)$$

where: $R_{\epsilon} = \frac{\epsilon_p}{\epsilon_q}$

However, from Equation (3) it can be seen that n becomes unmeaningfully large for small values of ϵ_{ϕ} , and infinite when ϵ_{ϕ} vanishes. In order to better illustrate the order of magnitude of the error due to gage misalignment, Equation (2) will be evaluated for a more-or-less typical case.

In a uniaxial stress field, $\epsilon_q = -\nu\epsilon_p$. And, for steel, $\nu = 0.285$.

Assume $\epsilon_p = 1000 \mu\epsilon$

Then, $\epsilon_q = -285 \mu\epsilon$

And, $n = -642.5 [\cos 2(\phi \pm \beta) - \cos 2\phi] \quad (5)$

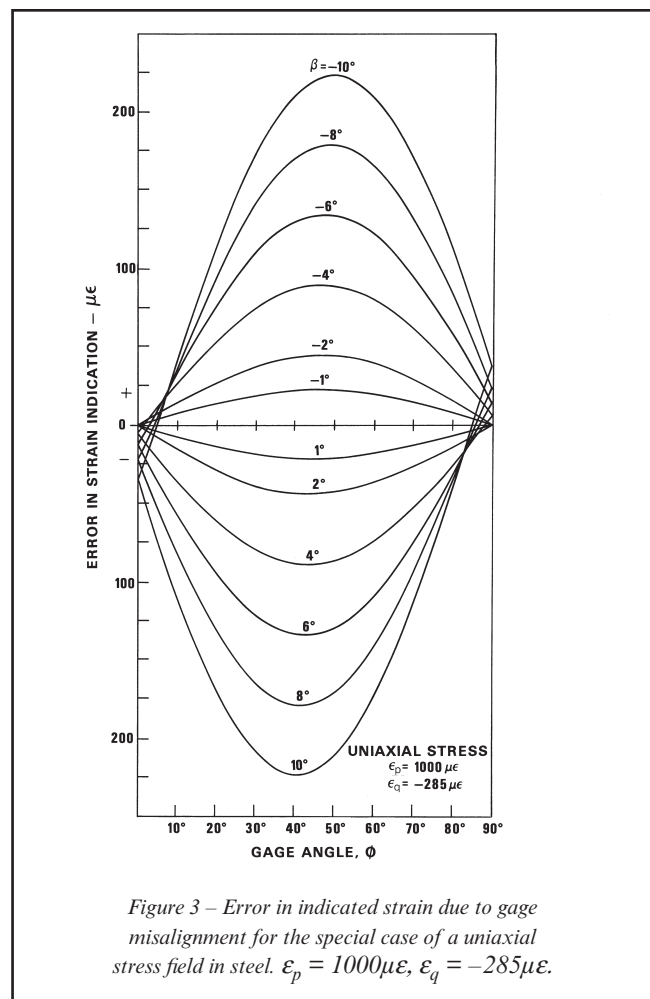

Figure 3 – Error in indicated strain due to gage misalignment for the special case of a uniaxial stress field in steel. $\epsilon_p = 1000 \mu\epsilon, \epsilon_q = -285 \mu\epsilon$.

Errors Due to Misalignment of Strain Gages

Equation (5) is plotted in Figure 3 over a range of ϕ from 0° to 90° , and over a range of mounting errors from 1° to 10° .

In order to correct for a known misalignment by reading the value of n from Figure 3, it is only necessary to solve Equation (1) for ε_ϕ and substitute the value of n ; including the sign as given by Figure 3. This figure is given only as an example, and applies only to the case in which $\varepsilon_q = -0.285 \varepsilon_p$ (uniaxial stress in steel). Equation (2) can be used to develop similar error curves for any biaxial strain state.

Two-Gage Rectangular Rosette

While the above analysis of the errors due to misalignment of a single gage may help in understanding the nature of such errors, the 90-degree, two-gage rosette is of considerably greater practical interest.

A two-gage rectangular rosette is ordinarily used by stress analysts for the purpose of determining the principal stresses when the direction of the principal axes are known from other sources. In this case, the rosette should be bonded in place with the gage axes coincident with the principal axes. Whether there is an error in orientation of the rosette with respect to the principal axes, or in the locations of the principal axes themselves, there will be a corresponding error in the principal stresses as calculated from the strain readings.

In Figure 4, a general biaxial strain field is shown, with the axes of a two-gage rosette, misaligned by the angle β , superimposed. The percentage errors in the principal stresses and maximum shear stress due to the misalignment are:

$$n_{\sigma_p} = \frac{\hat{\sigma}_p - \sigma_p}{\sigma_p} \times 100 \quad (6)$$

$$n_{\sigma_p} = \frac{(1-R_\varepsilon)(1-\nu)(1-\cos 2\beta)}{2(R_\varepsilon+\nu)} \times 100 \quad (7)$$

$$n_{\sigma_q} = \frac{\hat{\sigma}_q - \sigma_q}{\sigma_q} \times 100 \quad (8)$$

$$n_{\sigma_q} = \frac{(R_\varepsilon-1)(1-\nu)(1-\cos 2\beta)}{2(1+\nu R_\varepsilon)} \times 100 \quad (9)$$

$$n_{\tau_{MAX}} = \frac{\hat{\tau}_{MAX} - \tau_{MAX}}{\tau_{MAX}} \times 100 \quad (10)$$

$$n_{\tau_{MAX}} = -(1 - \cos 2\beta) \times 100 \quad (11)$$

where:

$\hat{\sigma}_p, \hat{\sigma}_q, \hat{\tau}_{MAX}$ are the principal stresses and maximum shear stress inferred from the indicated strains when the rosette is misaligned by the angle β .

$R_\varepsilon = \varepsilon_p / \varepsilon_q$, the ratio of the algebraic maximum to the algebraic minimum principal strain, as before.

Figure 4 – Biaxial strain field with rosette axes misaligned by the angle β from the principal axes.

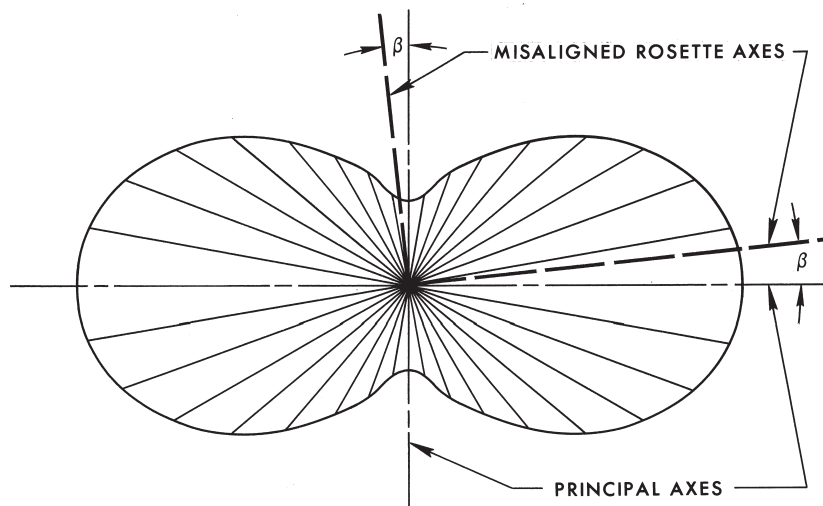

Errors Due to Misalignment of Strain Gages

When the principal strain ratio is replaced by the principal stress ratio, where:

$$R_{\sigma} = \frac{R_{\epsilon} + \nu}{1 + \nu R_{\epsilon}} = \frac{\sigma_p}{\sigma_q} \quad (12)$$

Or,

$$R_{\epsilon} = \frac{R_{\sigma} - \nu}{1 - \nu R_{\sigma}} = \frac{\epsilon_p}{\epsilon_q} \quad (13)$$

$$n_{\sigma_p} = \frac{1 - R_{\sigma}}{2R_{\sigma}}(1 - \cos 2\beta) \times 100 \quad (14)$$

$$n_{\sigma_q} = \frac{R_{\sigma} - 1}{2}(1 - \cos 2\beta) \times 100 \quad (15)$$

Equations (11), (14), and (15) will now be applied to an example in order to demonstrate the magnitudes of the errors encountered.

Consider first a thin-walled cylindrical pressure vessel. In this case, the hoop stress or circumferential stress is twice the longitudinal stress, and of the same sign.

Thus,

$$\frac{\sigma_p}{\sigma_q} = R_{\sigma} = 2$$

And Equations (11), (14), and (15) become:

$$n_{\tau_{MAX}} = -1(1 - \cos 2\beta) \times 100 \quad (11a)$$

$$n_{\sigma_p} = -1/4(1 - \cos 2\beta) \times 100 \quad (14a)$$

$$n_{\sigma_q} = -1/2(1 - \cos 2\beta) \times 100 \quad (15a)$$

Equations (11a), (14a), and (15a) are plotted in Figure 5. From the figure, it can be seen that the errors introduced by rosette misalignment in this instance are quite small. For example, with a 5° mounting error, τ_{MAX} , σ_p , and σ_q are in error by only -1.5%, -0.38%, and 0.75%, respectively.

In order to correct for a known misalignment by reading the value of n from Figure 5, or any similar graph derived from the basic error equations [Equations (7), (9), (11), (14), (15)], it is only necessary to solve Equations (6), (8),

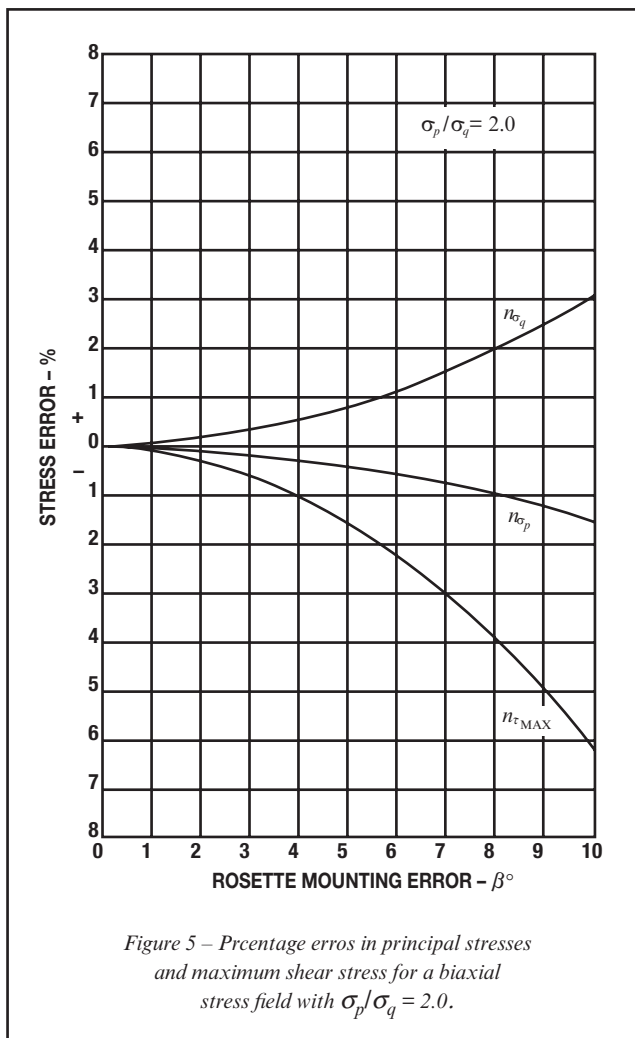

Figure 5 – Percent errors in principal stresses and maximum shear stress for a biaxial stress field with $\sigma_p/\sigma_q = 2.0$.

and (10) for σ_p , σ_q , and τ_{MAX} , respectively, and substitute the value of n from Figure 5, including the sign. That is,

$$\sigma_p = \frac{\hat{\sigma}_p}{1 + \frac{n_{\sigma_p}}{100}} \quad (16)$$

$$\sigma_q = \frac{\hat{\sigma}_q}{1 + \frac{n_{\sigma_q}}{100}} \quad (17)$$

$$\tau_{MAX} = \frac{\hat{\tau}_{MAX}}{1 + \frac{n_{\tau_{MAX}}}{100}} \quad (18)$$

Errors Due to Misalignment of Strain Gages

where:

$\hat{\sigma}_p$ = maximum principal stress as calculated from gage readings

$\hat{\sigma}_q$ = minimum principal stress as calculated from gage readings

$\hat{\tau}_{MAX}$ = maximum shear stress as calculated from

$$\hat{\tau}_{MAX} = \frac{\hat{\sigma}_p - \hat{\sigma}_q}{2}$$

While the errors in the above case were very small, this is not true for stress fields involving extremes of $R\sigma$. In general, n_{σ_p} becomes very large for $|R\sigma| \ll 1.0$, as does n_{σ_q} for $|R\sigma| \gg 1.0$. The error in shear stress is independent of the stress state.

The above generalities can be demonstrated by extending the previous case of the pressurized cylinder. Consider

an internally pressurized cylinder with an axial compressive load applied externally to the ends. If, for example, the load were $0.8 \pi r^2 p$, where r is the inside radius of the cylinder, and p is the internal pressure, the principal stress ratio would become,

$$R\sigma = 10$$

Equations (14) and (15) become:

$$n_{\sigma_p} = -0.45(1 - \cos 2\beta) \times 100 \quad (14b)$$

$$n_{\sigma_q} = 4.5(1 - \cos 2\beta) \times 100 \quad (15b)$$

For this case, a 5° error in mounting the rosette produces a -0.68% error in σ_p and a 6.75% error in σ_q .

The errors defined and evaluated in the foregoing occur, in each case, due to misalignment of a single strain gage or of an entire rosette. The effect of misalignment among the individual gages within a rosette is the subject of a separate study.



INTERTECHNOLOGY

1 Scarsdale Road, Don Mills, ON M3B 2R2

Tel: 416-445-5500 Fax: 416-445-1170

TOLL FREE: 1-800-465-1600

E-Mail: sales@intertechnology.com

Website: www.intertechnology.com