



STRAIN GAGE ROSETTES – SELECTION, APPLICATION AND DATA REDUCTION

Tech Note TN-515

1.0 Introduction

A strain gage rosette is, by definition, an arrangement of two or more closely positioned gage grids, separately oriented to measure the normal strains along different directions in the underlying surface of the test part. Rosettes are designed to perform a very practical and important function in experimental stress analysis. It can be shown that for the not-uncommon case of the general biaxial stress state, with the principal directions unknown, three independent strain measurements (in different directions) are required to determine the principal strains and stresses. And even when the principal directions are known in advance, two independent strain measurements are needed to obtain the principal strains and stresses.

To meet the foregoing requirements, the Vishay Micro-Measurements Division manufactures three basic types of strain gage rosettes (each in a variety of forms):

- *Tee*: two mutually perpendicular grids.
- *45°-Rectangular*: three grids, with the second and third grids angularly displaced from the first grid by 45° and 90°, respectively.
- *60°-Delta*: three grids, with the second and third grids 60° and 120° away, respectively, from the first grid.

Representative gage patterns for the three rosette types are reproduced in Figure 1.

In common with single-element strain gages, rosettes are manufactured from different combinations of grid alloy and backing material to meet varying application requirements.

They are also offered in a number of gage lengths, noting that the gage length specified for a rosette refers to the active length of each individual grid within the rosette. As illustrated in Figure 2, rectangular and delta rosettes may appear in any of several geometrically different, but functionally equivalent, forms. Guidance in choosing the most suitable rosette for a particular application is provided in *Section 2.0*, where selection considerations are reviewed.

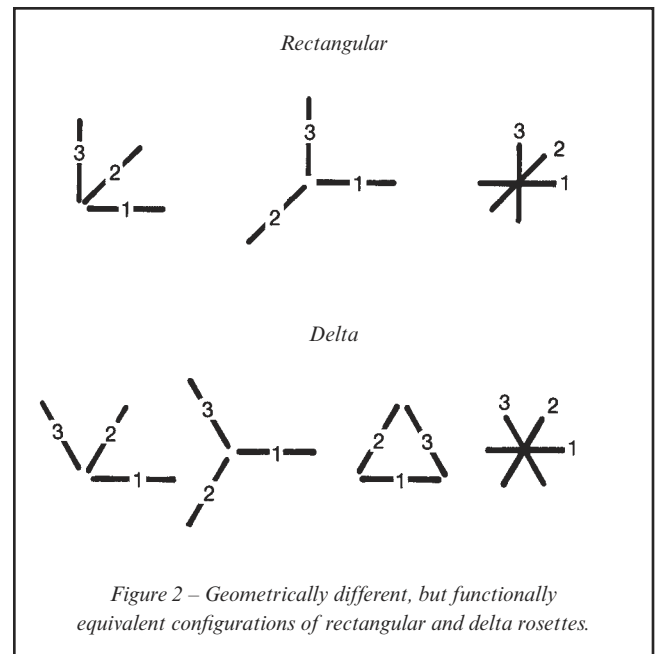

Figure 2 – Geometrically different, but functionally equivalent configurations of rectangular and delta rosettes.

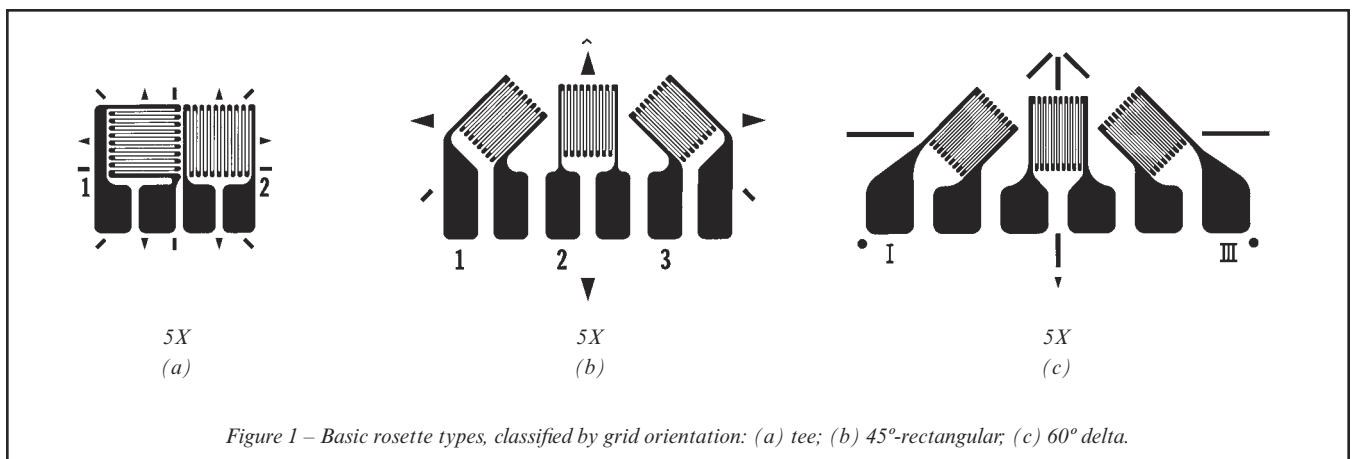

Figure 1 – Basic rosette types, classified by grid orientation: (a) tee; (b) 45°-rectangular; (c) 60° delta.

Strain Gage Rosettes – Selection, Application and Data Reduction

Since biaxial stress states occur very commonly in machine parts and structural members, it might be presumed that half or so of the strain gages used in experimental stress analysis would be rosettes. This does not seem to be the case, however, and ten percent (or less) rosette usage may be more nearly representative. To what degree this pattern of usage reflects an inclination for on-site makeup of rosettes from single-element gages, or simply an undue tendency to assume uniaxiality of the stress state, is an open question. At any rate, neither practice can generally be recommended for the accurate determination of principal strains.

It must be appreciated that while the use of strain gage rosette is, in many cases, a *necessary* condition for obtaining the principal strains, it is not a *sufficient* condition for doing so accurately. Knowledgeability in the selection and application of rosettes is critical to their successful use in experimental stress analysis; and the information contained in this Tech Note is intended to help the user obtain reliably accurate principal strain data.

2.0 Rosette Selection Considerations

A comprehensive guide for use in selecting Vishay Micro-Measurements strain gages is provided in Reference 1. This publication should first be consulted for recommendations on the strain-sensitive alloy, backing material, self-temperature-compensation number, gage length, and other strain gage characteristics suitable to the expected application. In addition to basic parameters such as the foregoing, which must be considered in the selection of any strain gage, two other parameters are important in rosette selection. These are: (1) the rosette type — tee, rectangular, or delta; and (2) the rosette construction — planar (single-plane) or stacked (layered).

The tee rosette should be used only when the principal strain directions are known in advance from other considerations. Cylindrical pressure vessels and shafts in torsion are two classical examples of the latter condition. However, care must be exercised in all such cases that extraneous stresses (bending, axial stress, etc.) are not present, since these will affect the directions of the principal axes. Attention must also be given to nearby geometric irregularities, such as holes, ribs, or shoulders, which can locally alter the principal directions. The error magnitudes due to misalignment of a tee rosette from the principal axes are given in Reference 2. As a rule, if there is uncertainty about the principal directions, a three-element rectangular or delta rosette is preferable. When necessary (and, *using the proper data-reduction relationships*), the tee rosette can be installed with its axes at any *precisely known* angle from the principal axes; but greatest accuracy will be achieved by alignment along the principal directions. In the latter case, except for the readily corrected error due to transverse sensitivity, the two gage elements in the rosette indicate the corresponding principal strains directly.

Where the directions of the principal strains are unknown, a three-element rectangular or delta rosette is always required; and the rosette can be installed without regard to orientation. The data-reduction relationships given in **Section 4.0** yield not only the principal strains, but also the directions for the principal axes relative to the reference grid (Grid 1) of the rosette. Functionally, there is little choice between the rectangular and delta rosettes. Because the gage axes in the delta rosette have the maximum possible uniform angular separation (effectively 120°), this rosette is presumed to produce the optimum sampling of the underlying strain distribution. Rectangular rosettes have historically been the more popular of the two, primarily because the data-reduction relationships are somewhat simpler. Currently, however, with the widespread access to computers and programmable calculators, the computational advantage of the rectangular rosette is of little consequence. As a result of the foregoing, the choice between rectangular and delta rosettes is more apt to be based on practical application considerations such as availability from stock, compatibility with the space available for installation, convenience of solder tab arrangement, etc.

All three types of rosettes (tee, rectangular, and delta) are manufactured in both planar and stacked versions. As indicated (for the rectangular rosette) in Figure 3, the planar

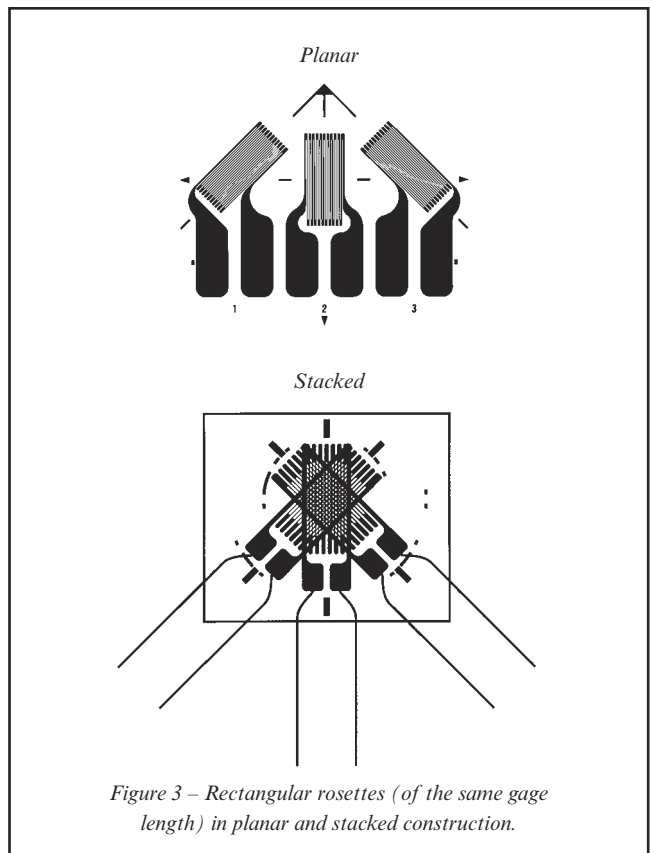

Figure 3 – Rectangular rosettes (of the same gage length) in planar and stacked construction.

Strain Gage Rosettes – Selection, Application and Data Reduction

rosette is etched from the strain-sensitive foil as an entity, with all gage elements lying in a single plane. The stacked rosette is manufactured by assembling and laminating two or three properly oriented single-element gages. When strain gradients in the plane of the test part surface are not too severe, the normal selection is the planar rosette. This form of rosette offers the following advantages in such cases:

- Thin and flexible, with greater conformability to curved surfaces;
- Minimal reinforcing effect;
- Superior heat dissipation to the test part;
- Available in all standard forms of gage construction, and generally accepts all standard optional features;
- Optimal stability;
- Maximum freedom in leadwire routing and attachment.

The principal disadvantages of the planar rosette arise from the larger surface area covered by the sensitive portion of the gage. When the space available for gage installation is small, a stacked rosette may fit, although a planar one will not. More importantly, where a steep strain gradient exists in the surface plane of the test part, the individual gage elements in a planar rosette may sense different strain fields and magnitudes. For a given active gage length, the stacked rosette occupies the least possible area, and has the centroids (geometric centers) of all grids lying over the same point on the test part surface. Thus, the stacked rosette more nearly approaches measurement of the strains at a point. Although normally a trivial consideration, it can also be noted that all gages in a stacked rosette have the same gage factor and transverse sensitivity, while the grids in a planar rosette will differ slightly in these properties, due to their different orientations relative to the rolling direction of the strain-sensitive foil. The technical data sheet accompanying the rosettes fully documents the separate properties of the individual grids.

It should be realized, however, that the stacked rosette is noticeably stiffer and less conformable than its planar counterpart. Also, because the heat conduction paths for the upper grids in a stacked rosette are much longer, the heat dissipation problem may be more critical when the rosette is installed on a material with low thermal conductivity. Taking into account their poorer heat dissipation and their greater reinforcement effects, stacked rosettes may not be the best choice for use on plastics and other nonmetallic materials. A stacked rosette can also give erroneous strain indications when applied to thin specimen in bending, since the grid plane of the uppermost gage in three-gage stack may be as much as 0.0045 in [0.11 mm] above the specimen surface. In short, the stacked rosette should ordinarily be reserved for applications in which the requirement for minimum surface area dictates its selection.

3.0 Gage Element Numbering

“Numbering”, as used here, refers to the numeric (or alphabetic) sequence in which the gage elements in a rosette are identified during strain measurement, and for substitution of measured strains into data-reduction relationships such as those given in *Section 4.0*. Contrary to a widely held impression, the subject of gage numbering is not necessarily a trivial matter. It is, in fact, basic to the proper, and complete, interpretation of rosette measurement.³ With any three-element rosette, misinterpretation of the rotational sequence (CW or CCW), for instance, can lead to incorrect principal strain directions. In the case of the rectangular rosette, an improper numbering order will produce completely erroneous principal strain magnitudes, as well as directions. These errors occur when the gage user’s numbering sequence differs from that employed in the derivation of the data-reduction relationships.

To obtain correct results using the data-reduction relationships provided in *Section 4.0* (and in the *Appendix*), the grids in three-element rosettes must be numbered in a particular way. It is always necessary in a rectangular rosette, for instance, that grid numbers 1 and 3 be assigned to two mutually perpendicular grids. Any other arrangement will produce incorrect principal strains. Following are the general rules for proper rosette numbering. With a rectangular rosette, the axis of Grid 2 must be 45° away, in the same rotational direction. Similarly, with a delta rosette, the axes of Grids 2 and 3 must be 60° and 120° away, respectively, in the same direction from Grid 1.

In principle, the preceding rules could be implemented by numbering the grids in either the clockwise or counterclockwise direction, as long as the sequence is correct. Counterclockwise numbering is preferable, however, because it is consistent with the usual engineering practice of denoting counterclockwise angular measurement as positive in sign. The gage grids in all Vishay Micro-Measurements general-purpose, three-element planar rosettes (rectangular and delta) are numerically identified, and numbered in the counterclockwise direction.* Examples of the grid numbering for several representative rosette types are illustrated in Figure 4. At first glimpse, it might appear that gage patterns (b) and (c) are numbered clockwise instead of counterclockwise. But when these patterns are examined more closely, and when the axis of Grid 2 is transposed across the grid-circle diameter to satisfy the foregoing numbering rules, it can be seen that the rosette numbering is counterclockwise in every case. Vishay Micro-Measurements stacked rosettes are not numbered, as a matter of manufacturing economics. The

* Vishay Micro-Measurements also supplies special-purpose planar rectangular rosettes designed exclusively for use with the hole-drilling method of residual stress analysis. Since these rosettes require different data-reduction relationships, procedures, and interpretation, they are numbered clockwise to distinguish them from general-purpose rosettes.

Strain Gage Rosettes – Selection, Application and Data Reduction

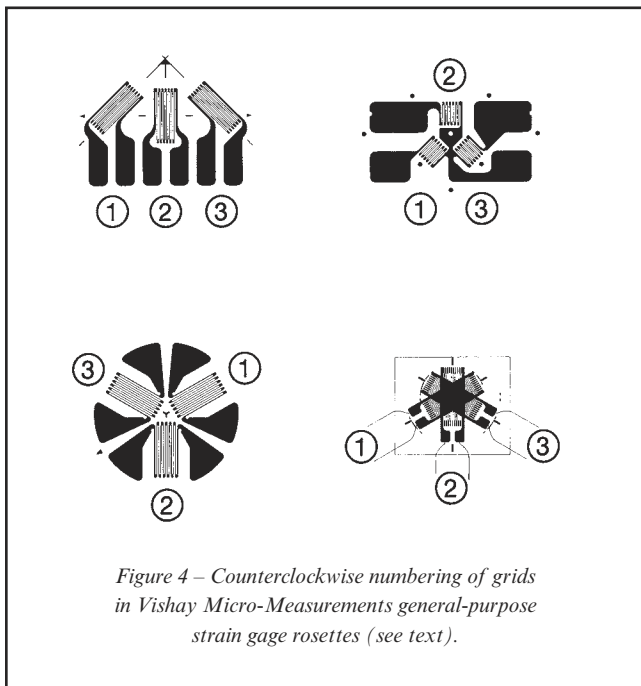

Figure 4 – Counterclockwise numbering of grids in Vishay Micro-Measurements general-purpose strain gage rosettes (see text).

user should number the gages in stacked rosettes according to the rules given here and illustrated in Figures 2 and 4.

4.0 Principal Strains and Directions from Rosette Measurements

The equations for calculating principal strains from three rosette strain measurements are derived from what is known as a “strain-transformation” relationship. As employed here in its simplest form, such a relationship expresses the normal strain in any direction on a test surface in terms of the two principal strains and the angle from the principal axis to the direction of the specified strain. This situation can be envisioned most readily with the aid of the well-known Mohr’s circle for strain, as shown in Figure 5**. It can be seen from Figure 5a (noting that the angles in Mohr’s circle are double the physical angles on the test surface) that the normal strain at any angle θ from the major principal axis is simply expressed by:

$$\epsilon_{\theta} = \frac{\epsilon_P + \epsilon_Q}{2} + \frac{\epsilon_P - \epsilon_Q}{2} \cos 2\theta \quad (1)$$

** The Mohr’s circle in Figure 5 is constructed with positive shear strain plotted downward. This is done so that the positive rotational direction in Mohr’s circle is the same (CCW) as for the rosette, while maintaining the usual sign convention for shear (i.e., positive shear corresponds to a reduction in the initial right angle at the origin of the X-Y axes as labeled in Figure 5b).

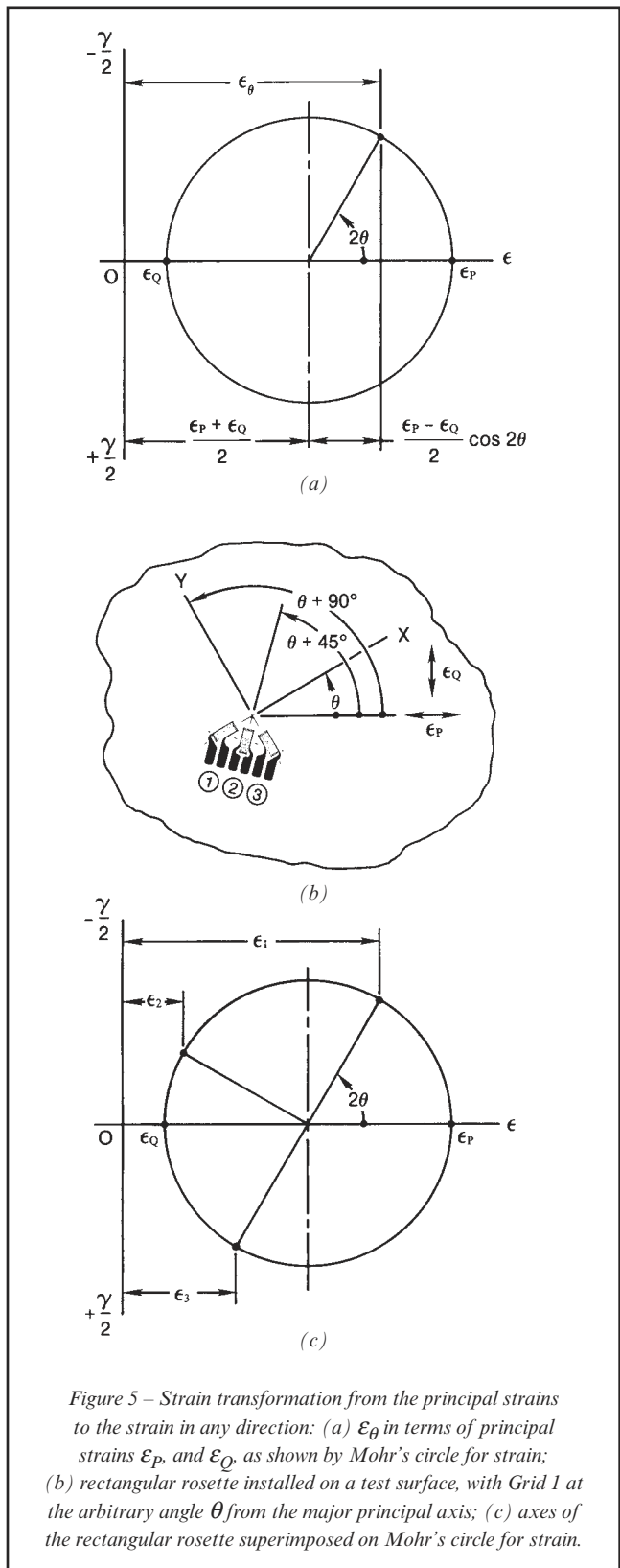

Figure 5 – Strain transformation from the principal strains to the strain in any direction: (a) ϵ_{θ} in terms of principal strains ϵ_P , and ϵ_Q , as shown by Mohr’s circle for strain; (b) rectangular rosette installed on a test surface, with Grid 1 at the arbitrary angle θ from the major principal axis; (c) axes of the rectangular rosette superimposed on Mohr’s circle for strain.

Strain Gage Rosettes – Selection, Application and Data Reduction

Figure 5b represents a small area of the test surface, with a rectangular rosette installed, and with the reference grid (#1) oriented at θ degrees from ϵ_p . Mohr's circle, with the axes of the rosette superimposed, is shown in Figure 5c.

By successively substituting into Equation (1) the angles for the three grid directions, the strain sensed by each grid can be expressed as follows:

$$\epsilon_1 = \frac{\epsilon_P + \epsilon_Q}{2} + \frac{\epsilon_P - \epsilon_Q}{2} \cos 2\theta \quad (2a)$$

$$\epsilon_2 = \frac{\epsilon_P + \epsilon_Q}{2} + \frac{\epsilon_P - \epsilon_Q}{2} \cos 2(\theta + 45^\circ) \quad (2b)$$

$$\epsilon_3 = \frac{\epsilon_P + \epsilon_Q}{2} + \frac{\epsilon_P - \epsilon_Q}{2} \cos 2(\theta + 90^\circ) \quad (2c)$$

When the rosette is installed on a test part subjected to an arbitrary strain state, the variables on the right-hand side of Equations (2) are unknown. But the strains ϵ_1 , ϵ_2 and ϵ_3 can be measured. Thus, by solving Equations (2) simultaneously for the unknown quantities ϵ_P , ϵ_Q , and θ , the principal strains and angle can be expressed in terms of the three measured strains. Following is the result of this procedure:

$$\epsilon_{P,Q} = \frac{\epsilon_1 + \epsilon_3}{2} \pm \frac{1}{\sqrt{2}} \sqrt{(\epsilon_1 - \epsilon_2)^2 + (\epsilon_2 - \epsilon_3)^2} \quad (3)$$

$$\theta = \frac{1}{2} \tan^{-1} \left(\frac{\epsilon_1 - 2\epsilon_2 + \epsilon_3}{\epsilon_1 - \epsilon_3} \right) \quad (4)$$

If the rosette is properly numbered, the principal strains can be calculated from Equation (3) by substituting the measured strains for ϵ_1 , ϵ_2 and ϵ_3 . The plus and minus alternatives in Equation (3) yield the algebraically maximum and minimum principal strains, respectively. Unambiguous determination of the principal angle from Equation (4) requires, however, some interpretation, as described in the following. To begin with, the angle θ represents the acute angle *from* the principal axis *to* the reference grid of the rosette, as indicated in Figure 5. In the practice of experimental stress analysis, it is somewhat more convenient, and easier to visualize, if this is reexpressed as the angle *from* Grid 1 *to* the principal axis. To change the sense of the angle requires only reversing the sign of Equation (4). Thus:

$$\phi_{P,Q} = -\theta = \frac{1}{2} \tan^{-1} \left(\frac{2\epsilon_2 - \epsilon_1 + \epsilon_3}{\epsilon_1 - \epsilon_3} \right) \quad (5)$$

The physical direction of the acute angle given by either Equation (4) or Equation (5) is always counterclockwise if positive, and clockwise if negative. The only difference is that θ is measured from the principal axis to Grid 1, while ϕ is measured from Grid 1 to the principal axis. Unfortunately, since $\tan 2\phi \equiv \tan 2(\phi + 90^\circ)$, the calculated angle can refer to either principal axis; and hence the identification in Equation (5) as $\phi_{P,Q}$. This ambiguity can readily be resolved (for the rectangular rosette) by application of the following simple rules:

- (a) if $\epsilon_1 > \epsilon_3$, then $\phi_{P,Q} = \phi_P$
- (b) if $\epsilon_1 < \epsilon_3$, then $\phi_{P,Q} = \phi_Q$
- (c) if $\epsilon_1 = \epsilon_3$ and $\epsilon_2 < \epsilon_1$, then $\phi_{P,Q} = \phi_P = -45^\circ$
- (d) if $\epsilon_1 = \epsilon_3$ and $\epsilon_2 > \epsilon_1$, then $\phi_{P,Q} = \phi_P = +45^\circ$
- (e) if $\epsilon_1 = \epsilon_2 = \epsilon_3$, then $\phi_{P,Q}$ is indeterminate (equal biaxial strain).

The reasoning which underlies the preceding rules becomes obvious when a sketch is made of the corresponding Mohr's circle for strain, and the rosette axes are superimposed as in Figure 5c. A similar technique for assuring correct interpretation of the angle is given in the form of a step-by-step algorithm in Reference 3.

The preceding development has been applied to the rectangular rosette, but the same procedure can be used to derive corresponding data-reduction equations for the delta rosette shown in Figure 6. When grid angles θ , $\theta + 60^\circ$, and $\theta + 120^\circ$ are successively substituted into Equation (1), the resulting three equations can again be solved simultaneously for the principal strains and angle. Thus, for the delta rosette:

$$\epsilon_{P,Q} = \frac{\epsilon_1 + \epsilon_2 + \epsilon_3}{3} \pm \frac{\sqrt{2}}{3} \sqrt{(\epsilon_1 - \epsilon_2)^2 + (\epsilon_2 - \epsilon_3)^2 + (\epsilon_3 - \epsilon_1)^2} \quad (6)$$

$$\theta = \frac{1}{2} \tan^{-1} \left(\frac{\sqrt{3}(\epsilon_3 - \epsilon_2)}{2\epsilon_1 - \epsilon_2 - \epsilon_3} \right) \quad (7)$$

As in the case of Equation (4), the angle θ calculated from Equation (7) refers to the angular displacement of Grid 1 from the principal axis. The sense of the angle can again be changed by reversing its sign to give the angle from Grid 1 to a principal axis:

$$\phi_{P,Q} = -\theta = \frac{1}{2} \tan^{-1} \left(\frac{\sqrt{3}(\epsilon_2 - \epsilon_3)}{2\epsilon_1 - \epsilon_2 - \epsilon_3} \right) \quad (8)$$

Strain Gage Rosettes – Selection, Application and Data Reduction

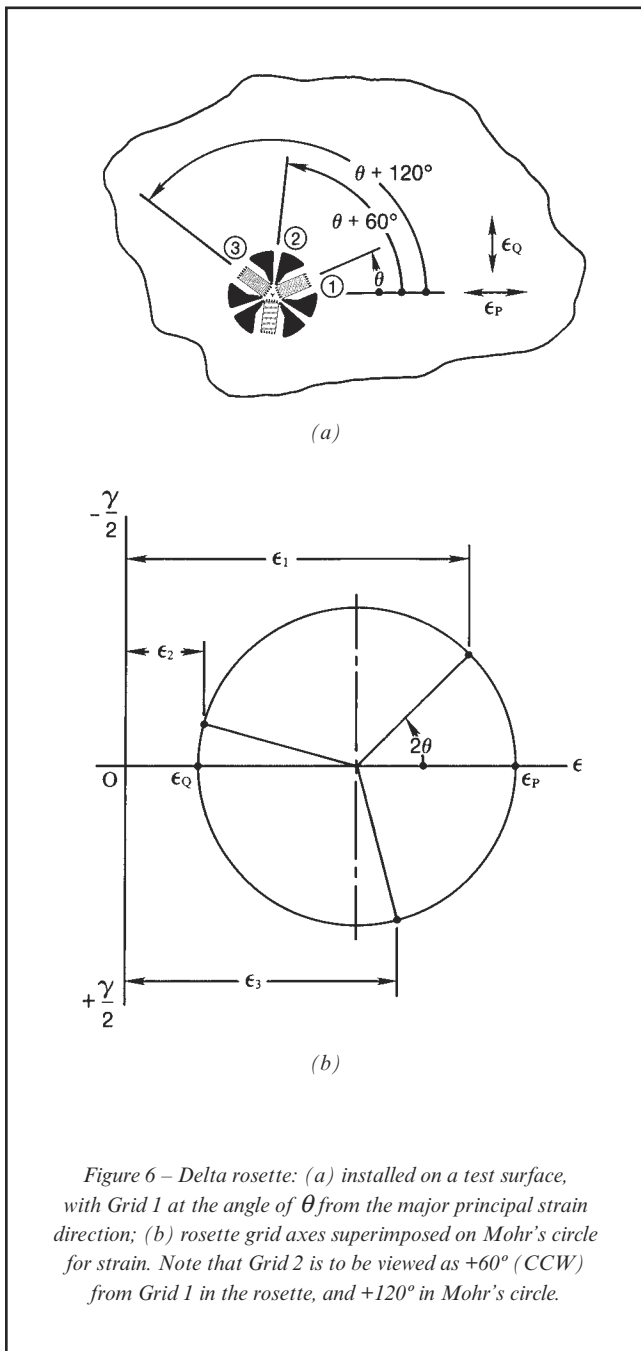

Figure 6 – Delta rosette: (a) installed on a test surface, with Grid 1 at the angle of θ from the major principal strain direction; (b) rosette grid axes superimposed on Mohr's circle for strain. Note that Grid 2 is to be viewed as $+60^\circ$ (CCW) from Grid 1 in the rosette, and $+120^\circ$ in Mohr's circle.

In every case [Equations (4), (5), (7), and (8)], the angles are to be interpreted as counterclockwise if positive, and clockwise if negative.

Equation (8) embodies the same ambiguity with respect to the $\tan 2\theta$ and $\tan 2(\theta + 90^\circ)$ as Equation (5). As before, the ambiguity can easily be resolved (for the delta rosette) by considering the relative magnitudes (algebraically) among the individual strain measurements; namely:

- (a) if $\epsilon_1 > \frac{\epsilon_2 + \epsilon_3}{2}$, then $\phi_{P,Q} = \phi_P$
- (b) if $\epsilon_1 < \frac{\epsilon_2 + \epsilon_3}{2}$, then $\phi_{P,Q} = \phi_Q$
- (c) if $\epsilon_1 = \frac{\epsilon_2 + \epsilon_3}{2}$, and $\epsilon_2 < \epsilon_1$, then $\phi_{P,Q} = \phi_P = -45^\circ$
- (d) if $\epsilon_1 = \frac{\epsilon_2 + \epsilon_3}{2}$, and $\epsilon_2 > \epsilon_1$, then $\phi_{P,Q} = \phi_P = +45^\circ$
- (3) if $\epsilon_1 = \epsilon_2 = \epsilon_3$ then $\phi_{P,Q}$ is indeterminate (equal biaxial strain)

When the principal angle is calculated automatically by computer from Equation (5) or Equation (8), it is always necessary of course, to avoid the condition of division by zero if $\epsilon_1 = \epsilon_3$ with a rectangular rosette, or $\epsilon_1 = (\epsilon_2 + \epsilon_3)/2$ with a delta rosette. For this reason, the computer should be programmed to perform the foregoing (c) and (d) tests, in each case, prior to calculating the arc-tangent.

Once the principal strains have been determined from Equation (3) or Equation (6), the strain state in the surface of the test part is completely defined. If desired, the maximum shear strain can be obtained directly from:

$$\gamma_{MAX} = \epsilon_P - \epsilon_Q \tag{9}$$

Intuitive understanding of the strain state can also be enhanced by sketching the corresponding Mohr's circle, approximately to scale. In Equations (3) and (6), the first term represents, in each case, the distance from the origin to the center of the circle, and the second term represents the radius, or $\gamma_{MAX}/2$. With the angle ϕ calculated, further insight can be gained by superimposing the rosette grid axes on the Mohr's circle, as in Figures 5c and 6b.

5.0 Principal Stresses from Principal Strains

As previously noted, a three-element strain gage rosette must be employed to determine the principal strains in a general biaxial stress state when the directions of the principal axes are unknown. The usual goal of experimental stress analysis, however, is to arrive at the principal stresses, for comparison with some criterion of failure. With the strain state fully established as described in Section 4.0, the complete state of stress (in the surface of the test part) can also be obtained quite easily when the test material meets certain requirements on its mechanical properties. Since some

Strain Gage Rosettes – Selection, Application and Data Reduction

types of strain gage instrumentation, such as our System 6000, calculate both the principal strains and the principal stresses, the following material is provided as background information.

If the test material is homogeneous in composition, and is isotropic in its mechanical properties (i.e., the properties are the same in every direction), and if the stress/strain relationship is linear, with stress proportional to strain, then the biaxial form of Hooke's law can be used to convert the principal strains into principal stresses. This procedure requires, of course, that the elastic modulus (E) and Poisson's ratio (ν) of the material be known. Hooke's law for the biaxial stress state can be expressed as follows:

$$\sigma_P = \frac{E}{1-\nu^2}(\epsilon_P + \nu\epsilon_Q) \quad (10a)$$

$$\sigma_Q = \frac{E}{1-\nu^2}(\epsilon_Q + \nu\epsilon_P) \quad (10b)$$

The numerical values of the principal strains calculated from Equation (3) or Equation (6) can be substituted into equations (10), along with the elastic properties, to obtain the principal stresses. As an alternative, Equation (3) or Equation (6) depending on the rosette type) can be substituted algebraically into Equations (10) to express the principal stresses directly in terms of the three measured strains and the material properties. The results are as follows:

Rectangular:

$$\sigma_{P,Q} = \frac{E}{2} \left[\frac{\epsilon_1 + \epsilon_3}{1-\nu} \pm \frac{\sqrt{2}}{1+\nu} \sqrt{(\epsilon_1 - \epsilon_2)^2 + (\epsilon_2 - \epsilon_3)^2} \right] \quad (11)$$

Delta:

$$\sigma_{P,Q} = \frac{E}{3} \left[\frac{\epsilon_1 + \epsilon_2 + \epsilon_3}{1-\nu} \pm \frac{\sqrt{2}}{1+\nu} \sqrt{(\epsilon_1 - \epsilon_2)^2 + (\epsilon_2 - \epsilon_3)^2 + (\epsilon_3 - \epsilon_1)^2} \right] \quad (12)$$

When the test material is isotropic and linear-elastic in its mechanical properties (as required for the validity of the preceding strain-to-stress conversion), the principal stress axes coincide in direction with the principal strains. Because of this, the angle from Grid 1 of the rosette to the principal

stress direction is given by Equation (5) for rectangular rosettes, and by Equation (8) for delta rosettes.

6.0 Errors, Corrections, and Limitations

The obvious aim of experimental stress analysis is to determine the significant stresses in a test object as accurately as necessary to assure product reliability under expected service conditions. As demonstrated in the preceding sections of this Tech Note, the process of obtaining the principal stresses involves three basic, and sequential, steps: (1) measurement of surface strains with a strain gage rosette; (2) transformation of measured strains to principal strains; and (3) conversion of principal strains to principal stresses. Each step in this procedure has its own characteristic error sources and limits of applicability; and the stress analyst must carefully consider these to avoid potentially serious errors in the resulting principal stresses.

Of first importance is that the measured strains be as free as possible of error. Strain measurements with rosettes are subject, of course, to the same errors (thermal output, transverse sensitivity, leadwire resistance effects, etc.) as those with single-element strain gages. Thus, the same controlling and/or corrective measures are required to obtain accurate data. For instance, signal attenuation due to leadwire resistance should be eliminated by shunt calibration⁴, or by numerically correcting the strain data for the calculated attenuation, based on the known resistances of the leadwires and strain gages.

Because at least one of the gage grids in any rosette will in every case be subjected to a transverse strain which is equal to or greater than the strain along the grid axis, consideration should always be given to the transverse-sensitivity error when performing rosette data reduction. The magnitude of the error in any particular case depends on the transverse-sensitivity coefficient (K_t) of the gage grid, and on the ratio of the principal strains (ϵ_P/ϵ_Q). In general, when $K_t \leq 1\%$, the transverse-sensitivity error is small enough to be ignored. However, at larger values of K_t , depending on the required measurement accuracy, correction for transverse sensitivity may be necessary. Detailed procedures, as well as correction equations for all cases and all rosette types, are given in Reference 5.

When strain measurements must be made in a variable thermal environment, the thermal output of the strain gage can produce rather large errors, unless the instrumentation can be zero-balanced at the testing temperature, under strain-free conditions. In addition, the gage factor of the strain gage changes slightly with temperature. Reference 6 provides a thorough treatment of errors due to thermal effects in strain gages, including specific compensation and correction techniques for minimizing these errors.

After making certain that strain measurement errors such

Strain Gage Rosettes – Selection, Application and Data Reduction

as the foregoing have been eliminated or controlled to the degree feasible, attention can next be given to possible errors in the strain-transformation procedure for obtaining the principal strains. A potentially serious course of error can be created when the user attempts to make up a rosette on the specimen from three conventional single-element gages. The error is caused by misalignment of the individual gages within the rosette. If, for example, the second and third gages in a rectangular rosette configuration are not accurately oriented at 45° and 90°, respectively, from the first gage, the calculated principal strains will be in error.

The magnitude of the error depends, of course, on the magnitude (and direction) of the misalignment; but it also depends on the principal strain ratio, ϵ_p/ϵ_Q , and on the overall orientation of the rosette with respect to the principal axes. For certain combinations of principal strain ratio and rosette orientation, 5-degree alignment errors in gages 2 and 3 relative to Gage 1 can produce an error of 20 percent or more in one of the principal strains.

Since it is very difficult for most persons to install a small strain gage with the required precision in alignment, the user is well-advised to employ commercially available rosettes. The manufacturing procedures for Vishay Micro-Measurements strain gage rosettes are such that errors due to grid alignment within the rosette need never be considered. For those cases in which it is necessary, for whatever reason, to assemble a rosette from single-element gages, extreme care should be exercised to obtain accurate gage alignment. And when the principal strain directions can be predicted in advance, even approximately, alignment of Gage 1 or 3 in a rectangular rosette, or alignment of any gage in a delta rosette, with a principal axis, will minimize the error in that principal strain caused by inter-gage misalignment.

The strain-transformation relationships and data-reduction equations given in **Section 4.0** assume a uniform state of strain at the site of the rosette installation. Since the rosette necessarily covers a finite area of the test surface, severe variations in the strain field over this area can produce significant errors in the principal strains — particularly with planar rosettes.⁷ For this type of application, the stacked rosette is distinctly superior; both because it covers a much smaller area (for the same gage length), and because the centroids of all three grids lie over the same point on the test surface.

The requirements for a homogeneous material and uniform strain state can be (and are) relaxed under certain circumstances. A case in point is the use of strain gage rosettes on fiber-reinforced composite materials. If the distance between inhomogeneities in the material (i.e., fiber-to-fiber spacing) is small compared to the gage length of the rosette, each grid will indicate the “macroscopic” or average strain in the direction of its axis. These measured strains (after the usual error corrections) can be substituted into Equation (3) or Equation (6) to obtain the macroscopic principal strains

for use in the stress analysis of test objects made from composite materials.⁸ As noted later in this section, however, Equations (10)-(12) cannot be used for this purpose.

There is an additional limitation to the strain-transformation relationship in Equation (1) which, although not frequently encountered in routine experimental stress analysis, should be noted. The subject of the strain distribution about a point, as universally treated in handbooks and in mechanics of materials textbooks, is developed from what is known as “infinitesimal-strain” theory. That is, in the process of deriving relatively simple relationships such as Equation (1), the strain magnitudes are assumed to be small enough so that normal- and shear-strain approximations of the following types can be employed without introducing excessive error:

$$\epsilon + \epsilon_2 \approx \epsilon \quad (13)$$

$$\sin \gamma \approx \tan \gamma \approx \gamma \quad (14)$$

Although often unrecognized, these approximations are embodied in the equations used throughout the contemporary practice of theoretical and experimental stress analysis (where strain transformation is involved). This includes the concept of Mohr’s circle for strain, and thus all of the equations in **Section 4.0**, which are consistent with the strain circle. Infinitesimal-strain theory has proven highly satisfactory for most stress analysis applications with conventional structural materials, since the strains, if not truly “infinitesimal”, are normally very small compared to unity. Thus, for a not-untypical working strain level of 0.002 (2000 $\mu\epsilon$), the error in ignoring ϵ_2 compared to ϵ is only about 0.2 percent.

However, strain gage rosettes are sometimes used in the measurement of much larger strains, as in applications on plastics and elastomers, and in post-yield studies of metal behavior. Strain magnitudes greater than about 0.01 (10 000 $\mu\epsilon$) are commonly referred to as “large” or “finite”, and, for these, the strain-transformation relationship in Equation (1) may not adequately represent the actual variation in strain about a point. Depending on the strain magnitudes involved in a particular application, and on the required accuracy for the principal strains, it may be necessary to employ large-strain analysis methods for rosette data reduction.⁹

The final step in obtaining the principal stresses is the introduction of Hooke’s law (Equations (10)) for the biaxial stress state. To convert principal strains to principal stresses with Hooke’s law requires, of course, that the elastic modulus and Poisson’s ratio of the test material be known. Since the calculated stress is proportion to E , any error in the elastic modulus (for which a 3 to 5 percent uncertainty is

Strain Gage Rosettes – Selection, Application and Data Reduction

common) is carried directly through to the principal stress. An error in Poisson's ratio has a much smaller effect because of the subordinate role of ν in the relationship.

It is also necessary for the proper application of Hooke's law that the test material exhibit a linear relationship between stress and strain (constant E) over the range of working stresses. There is normally no problem in satisfying this requirement when dealing with common structural materials such as the conventional steel and aluminum alloys. Other materials (e.g., some plastics, cast iron and magnesium alloys, etc.) may, however, be distinctly nonlinear in their stress/strain characteristics. Since the process of transformation from measured strains to principal strains is independent of material properties, the correct principal strains in such materials can be determined from rosette measurements as described in this Tech Note. However, the principal strains cannot be converted accurately to principal stresses with the biaxial Hooke's law if the stress/strain relationship is perceptibly nonlinear.

A further requirement for the valid application of Hooke's law is that the test material be isotropic in its mechanical properties (i.e., that the elastic modulus and Poisson's ratio be the same in every direction). Although severely cold-worked metals may not be perfectly isotropic, this deviation from the ideal is commonly ignored in routine experimental stress analysis. In contrast, high-performance composite materials are usually fabricated with directional fiber reinforcement, and are thus strongly directional (orthotropic or otherwise anisotropic) in their mechanical properties. Hooke's law as expressed in Equations (10) is not applicable to these materials; and special "constitutive" relationships

are required to determine principal stresses from rosette strain measurements.⁸

References

1. Vishay Micro-Measurements Tech Note TN-505, "Strain Gage Selection — *Criteria, Procedures, Recommendations*".
2. Vishay Micro-Measurements Tech Note TN-511, "Errors Due to Misalignment of Strain Gages".
3. Perry, C.C., "Data-Reduction Algorithms for Strain Gage Rosette Measurements", *Experimental Techniques*, May, 1989, pp. 13-18.
4. Vishay Micro-Measurements Tech Note TN-514, "Shunt Calibration of Strain Gage Instrumentation".
5. Vishay Micro-Measurements Tech Note TN-509, "Errors Due to Transverse Sensitivity in Strain Gages".
6. Vishay Micro-Measurements Tech Note TN-504, "Strain Gage Thermal Output and Gage Factor Variation with Temperature".
7. Troke, .W., "Flat versus Stacked Rosettes", *Experimental Mechanics*, May, 1967, pp. 24A-28A.
8. Tsai, S.W. and H.T. Hahn, *Introduction to Composite Materials*, Technomic Publishing Company, 1980.
9. Meyer, M.L., "Interpretation of Surface-Strain Measurements in terms of Finite Homogeneous Strains". *Experimental Mechanics*, December, 1963, pp. 294-301.

Strain Gage Rosettes – Selection, Application and Data Reduction

Appendix

**Derivation of Strain-Transformation Relationship
 [Equation (1) in text] from Deformation Geometry**

Consider a small area of a test surface, as sketched in Figure A-1. The line O-P, of length L_O , and at the angle θ from the X axis, is scribed on the surface in the unstrained state. When uniform principal strains ϵ_P and ϵ_Q are applied in the directions of the X and Y axes, respectively, the point P moves to P' as a result of the displacements ΔX and ΔY (greatly exaggerated in the sketch).

It is evident from the figure that:

$$\Delta X = \epsilon_P (L_O \cos \theta) \quad (A-1)$$

$$\Delta Y = \epsilon_Q (L_O \sin \theta) \quad (A-2)$$

It can also be seen (Figure A-2), by enlarging the detail in the vicinity of points P and P', that for small strains:

$$\Delta L \approx \Delta X \cos \theta + \Delta Y \sin \theta \quad (A-3)$$

Substituting from Equations (A-1) and (A-2),

$$\Delta L \approx L_O (\epsilon_P \cos^2 \theta + \epsilon_Q \sin^2 \theta) \quad (A-3)$$

Or,

$$\epsilon_\theta = \frac{\Delta L}{L_O} = \epsilon_P \cos^2 \theta + \epsilon_Q \sin^2 \theta \quad (A-5)$$

But,

$$\cos^2 \theta = \frac{1}{2}(1 + \cos 2\theta)$$

$$\sin^2 \theta = \frac{1}{2}(1 - \cos 2\theta)$$

After substituting the above identities,

$$\epsilon_\theta = \frac{\epsilon_P + \epsilon_Q}{2} + \frac{\epsilon_P - \epsilon_Q}{2} \cos 2\theta \quad (A-6)$$

Alternate Data Reduction Equations

In the extensive technical literature dealing with strain gage rosettes, the user will often encounter data-reduction relationships which are noticeably different from one another, and from those in the body of this Tech Note. As a rule, these published equations yield the same results, and differ only in algebraic format — although proving so in any given case may be rather time consuming. Since certain forms of the equations may be preferred for mnemonic reasons, or for computational convenience, several alternative expressions are given here. All of the following are equally correct when the gage elements in the rosette are numbered as described in this Tech Note.

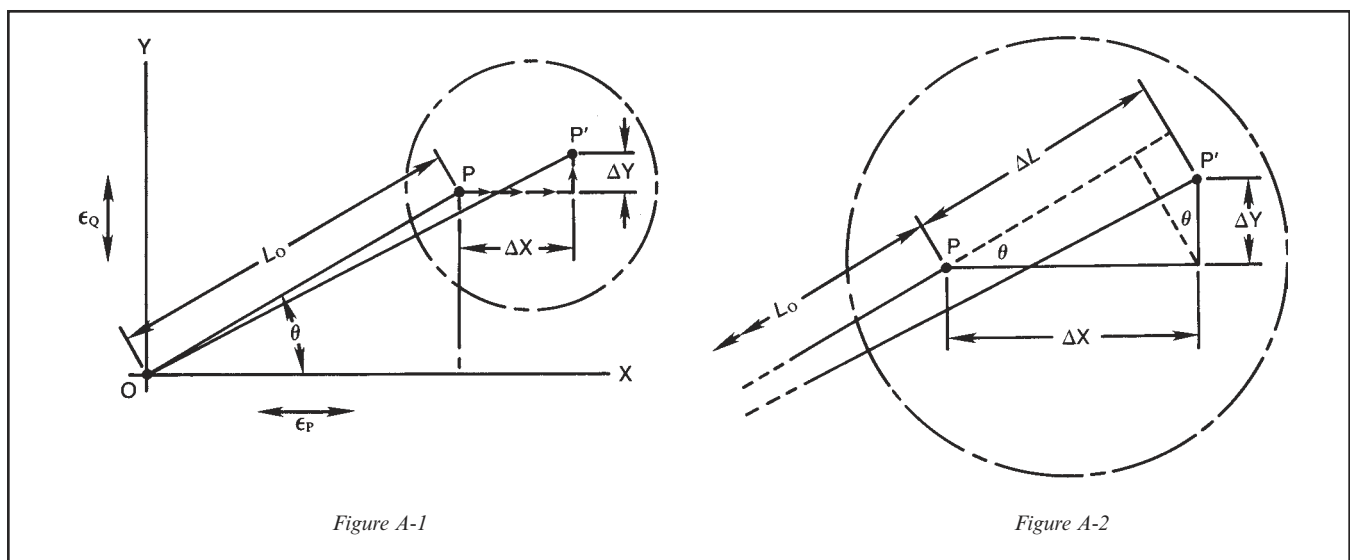

Figure A-1

Figure A-2

Strain Gage Rosettes – Selection, Application and Data Reduction

Rectangular Rosette:

$$\varepsilon_{P,Q} = \frac{\varepsilon_1 + \varepsilon_3}{2} \pm \frac{1}{2} \sqrt{(\varepsilon_1 - \varepsilon_3)^2 + [2\varepsilon_2 - (\varepsilon_1 + \varepsilon_3)]^2} \quad (\text{A-7})$$

$$\varepsilon_{P,Q} = \frac{\varepsilon_1 + \varepsilon_3}{2} \pm \sqrt{[(\varepsilon_1 - \varepsilon_2)^2 + (\varepsilon_2 - \varepsilon_3)^2]} / 2 \quad (\text{A-8})$$

$$\varepsilon_{P,Q} = C \pm \sqrt{(C - \varepsilon_1)^2 + (C - \varepsilon_2)^2} \quad (\text{A-9})$$

where: $C = \frac{\varepsilon_1 + \varepsilon_3}{2} \quad (\text{A-9})$

Delta Rosette:

$$\varepsilon_{P,Q} = \frac{\varepsilon_1 + \varepsilon_2 + \varepsilon_3}{3} \pm \sqrt{\left[\frac{2\varepsilon_1 - (\varepsilon_2 + \varepsilon_3)}{3} \right]^2 + \frac{1}{3}(\varepsilon_2 - \varepsilon_3)^2} \quad (\text{A-10})$$

$$\varepsilon_{P,Q} = \frac{\varepsilon_1 + \varepsilon_2 + \varepsilon_3}{3} \pm \sqrt{2[(\varepsilon_1 - \varepsilon_2)^2 + (\varepsilon_2 - \varepsilon_3)^2 + (\varepsilon_3 - \varepsilon_1)^2]} / 9 \quad (\text{A-11})$$

$$\varepsilon_{P,Q} = C \pm \sqrt{2[(C - \varepsilon_1)^2 + (C - \varepsilon_2)^2 + (C - \varepsilon_3)^2]} / 3 \quad (\text{A-12})$$

where: $C = \frac{\varepsilon_1 + \varepsilon_2 + \varepsilon_3}{3}$

Cartesian Strain Components from Rosette Measurements

It is sometimes desired to obtain the Cartesian components of strain (ε_X , ε_Y , and γ_{XY}) relative to a specified set of X-Y coordinate axes. This need can arise, for example, when making strain measurements on orthotropic composite materials. The Cartesian strain components are also useful when calculating principal strains from rosette data using matrix transformation methods.*

When the X axis of the coordinate system coincides with the axis of the reference grid (Grid 1) of the rosette, the Cartesian components of strain are as follows:

Rectangular Rosette:

$$\begin{aligned} \varepsilon_X &= \varepsilon_1 \\ \varepsilon_Y &= \varepsilon_3 \\ \gamma_{XY} &= 2\varepsilon_2 - (\varepsilon_1 + \varepsilon_3) \end{aligned}$$

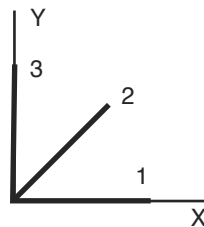

* Milner, R.R., "A Modern Approach to Principal Stresses and Strains", *Strain*, November, 1989, pp.135-138.

