



ERRORS DUE TO SHARED LEADWIRES IN PARALLEL STRAIN GAGE CIRCUITS

Tech Note TN-516

1.0 Introduction

The usual, and preferred, practice with multiple quarter-bridge strain gage installations used for either static or combined static/dynamic measurements is to employ a separate three-wire circuit for each gage. However, if a number of such gages are connected to a multiple-channel instrument which simultaneously uses the same power supply for several channels, the associated bridge circuits (each of which contains an active and dummy gage) are effectively in parallel. This arrangement, in itself, need not cause any problems, provided the power supply has sufficient capacity to maintain a constant voltage under varying load. If the two individual current-carrying P+ and P- power supply leadwires in each circuit have the same resistance and are subjected to the same temperature, their only contribution to measurement error is the usual desensitization of the gage factor. But this error can readily be eliminated by shunt calibration.

Unfortunately, the stress analyst may be motivated under certain circumstances to use a current-carrying leadwire that, as shown in Figure 1, is shared by, or common to, all the active gages. Savings of leadwire can be realized with this arrangement (sometimes called a "chevron") when the runs between gages and instrumentation are long. And, savings in manhours of installation time will be obtained when the number of installations is large. But, considering the potential problems created by the use of a common leadwire, the only valid motivations are those arising from physical and mechanical limitations. These may include the number of slip rings available for measurements on rotating equipment; the number of pass-through conductors possible in a barrier (like the wall of a pressure vessel) between the instrument and gages; and the use of multiple-grid gages with an integral bus or solder tab (common-tab rosettes and certain types of strip gages).

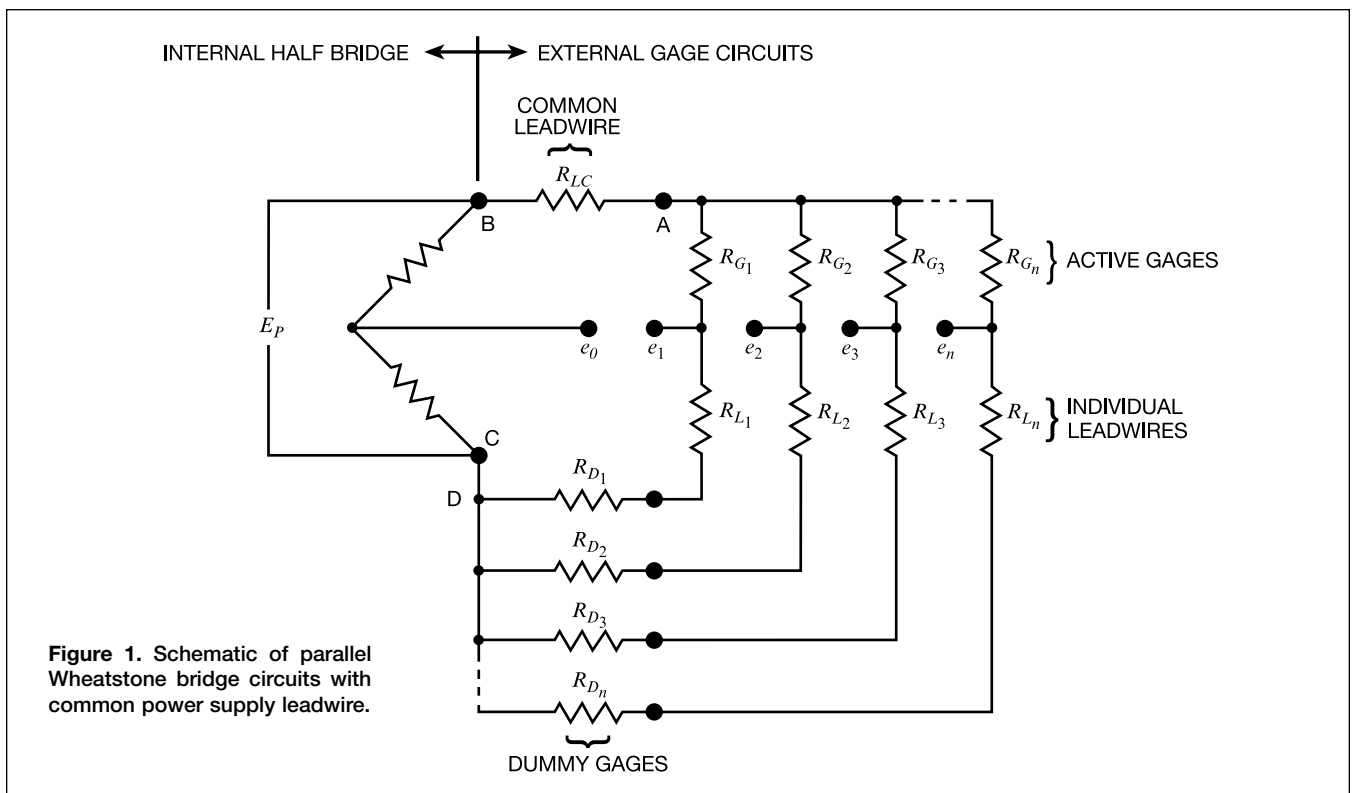

Figure 1. Schematic of parallel Wheatstone bridge circuits with common power supply leadwire.



Errors Due to Shared Leadwires in Parallel Strain Gage Circuits

A fundamental problem with the use of a common leadwire is that all data are vulnerable to degradation or even to complete loss should a single gage (or grid) malfunction. These malfunctions can range from a short circuit within a gage, to a low resistance to ground, to an open circuit. Although a primary reason for avoiding common leadwire usage, the risk of data loss is not directly relevant to the following discussion, and will not be treated further.

The more dangerous aspects of common leadwire usage arise from the often subtle effects that are produced when the gages function *properly*. Problems that can result from these include large initial resistive imbalances of the Wheatstone bridge circuits, inaccurate shunt calibration, crosstalk between gage circuits during strain measurement, and loss of leadwire temperature compensation. These are the primary subjects of the discussion that follows.

2.0 The Signal from Parallel Circuits

The electrical output, $e_o - e_i$, from each of the active gage circuits shown schematically in Figure 1 depends upon the power supply voltage, E_p , and the resistances of the common leadwire (R_{LC}), the active gages (R_{G_i}), the individual return leadwires (R_{L_i}), and the dummy gages (R_{D_i}). The resistances of the signal leads are relatively unimportant because no significant amount of current flows through them when a modern instrument with a high impedance input circuit is used to measure the signal voltage.

The resistance of the n parallel circuits between points A and C can be expressed as:

$$R_{A-C} = \frac{1}{\sum_{i=1}^n \left(\frac{1}{R_{G_i} + R_{L_i} + R_{D_i}} \right)} \quad (1)$$

provided that the resistance of the leadwire *between* the active gages (R_{G_i} and $R_{G_{i+1}}$) is negligible. Because the common leadwire has some finite resistance, it acts as a voltage divider to reduce the excitation voltage supplied to the active and dummy gages. And because it carries the sum of the currents in all the parallel circuits, the voltage drop in the common leadwire is n times as great as for individual return leadwires with the same resistance (provided all active and dummy gages have nominally the same resistance). The fraction, H , of the power supply voltage (E_p) available to the parallel circuits between points A and C for any combination of resistances in the parallel circuits is:

$$H = \frac{E_{A-C}}{E_p} = \frac{R_{A-C}}{(R_{A-C} + R_{LC})} \quad (2)$$

where E_{A-C} is the actual bridge excitation voltage across the parallel circuits (assumed to be the same for all). The signifi-

cance of this expression is that the current through the common leadwire and consequently the bridge excitation voltage at any given moment between points A and C depends upon not only the resistance of the common leadwire, the individual leadwires, and the dummy resistors, but also upon the *instantaneous* resistances of all the independently variable active gages in the parallel network. The effect that this phenomenon produces in the bridge output will be referred to in the following discussion as “crosstalk”.

Applying the “voltage division” fraction, H , to the active half-bridge term of the usual expression for output from a Wheatstone bridge, $e_o - e_i$, the signal from any active gage in the parallel circuit in Figure 1 can be calculated for any combination of resistance values:

$$e_o - e_i = E_p \left[\frac{1}{2} - \frac{H (R_{L_i} + R_{D_i})}{R_{G_i} + R_{L_i} + R_{D_i}} \right] \quad (3)$$

3.0 Initial Imbalance

Because the common leadwire does not affect the voltage across the internal half bridge, H is not applied to the $1/2$ term in Equation (3). This gives rise to the problem of an initial imbalance in every circuit, even when the active and dummy gages are of the same resistance. To illustrate the magnitude of the initial imbalance, consider the case of n parallel circuits in which all active and dummy gages are of the same resistance, R_G ; and all leadwires, including the common leadwire, have the same resistance, R_L . If the instrument gage factor control is set at 2.000, the initial imbalance, in microstrain units, is:

$$\epsilon_I = \frac{(n-1) R_L / R_G}{2 + (n+1) R_L / R_G} \times 10^6 \quad (4)$$

Equation (4) is plotted in Figure 2 (on page 3) for various combinations of the parameters n and R_L / R_G . As demonstrated by the figure, the imbalance can easily exceed the balance range of commercial strain indicators and signal-conditioning amplifiers.

4.0 Calibration Errors

Shunt calibration of the individual quarter-bridge circuits to adjust the instrument sensitivity would normally be done by shunting the “dummy” in one circuit, under the condition of zero output from the remaining parallel circuits. The use of a common leadwire causes no errors in the actual calibration process itself. However, when subsequent strain measurements are made, the strain-induced resistance changes in the individual gages produce changes in the values of R_{A-C} , H , and ultimately E_{A-C} . Consequently, the

Errors Due to Shared Leadwires in Parallel Strain Gage Circuits

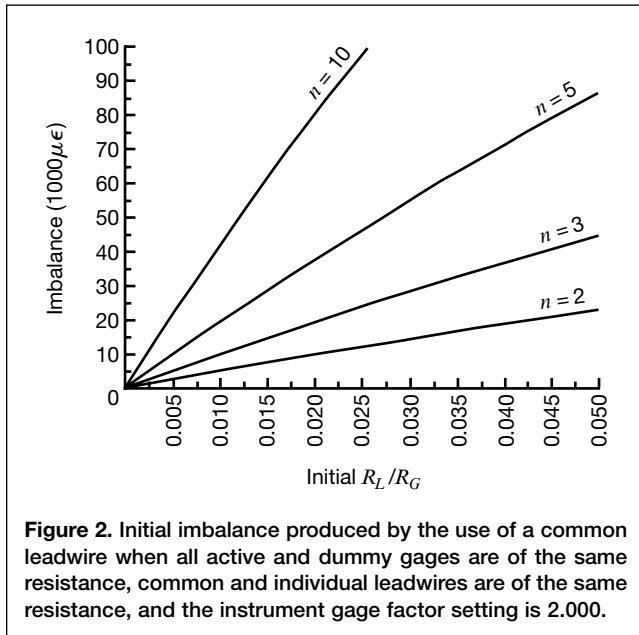

changes in E_{A-C} will cause the bridge output to vary, even when the resistance of the active gage corresponds to the calibration value. The calibration factor between resistance change and output voltage is then no longer correct for the calibrated circuit and the indicated strains will be in error. Accordingly, the calibration factor is generally correct only for the calibration conditions; namely, when the current through the common leadwire is the same as during calibration. The calibration error produced when the parallel gages are strained does not lend itself to generalization, but is symptomatic of the crosstalk between circuits treated in the following section.

5.0 Measurement Crosstalk Errors

Crosstalk refers to changes in both sensitivity and output produced in all parallel circuits by a resistance change in any one of the circuits. As in the case with the calibration error, this occurs because the resistance changes in each of the parallel circuits affect the voltage applied to—and consequently, the output from—all the other circuits.

Output errors can be partially generalized to yield a “cross-talk sensitivity index” like that shown in Figure 3. The approximate incremental output that will occur in each of the other circuits as the result of a $1000\mu\epsilon$ change in any one circuit is given by this graph. Note that this incremental output is not directly related to the magnitude of any other output that may be present due to strain in the affected circuits. Rather, these incremental outputs can be thought of as “output shifts” that are algebraically added to each of the indicated strains in the affected circuits. When the extent of

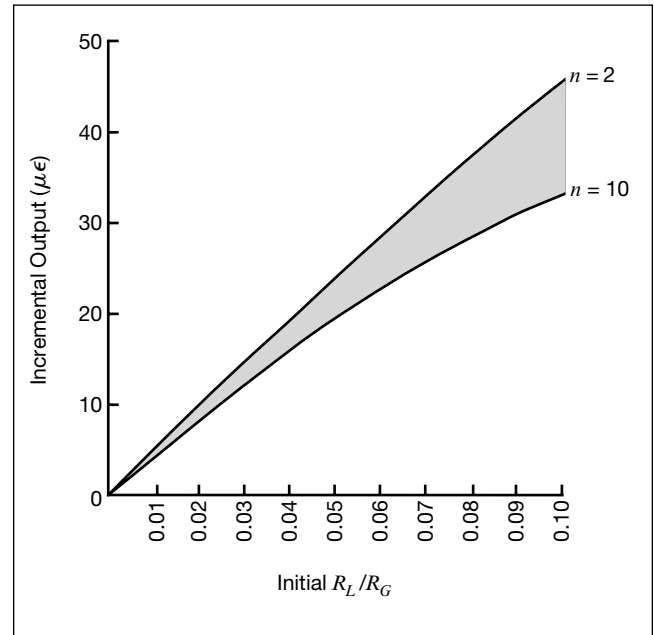

the incremental outputs caused by crosstalk must be known more precisely, Equation (3) should be used to calculate the outputs of all circuits under any set of “instantaneous” resistances. The errors produced by crosstalk are relatively small in comparison to those that can arise from the loss of leadwire temperature compensation as described in the following section.

6.0 Leadwire Temperature Errors

In a single, *isolated*, three-wire, quarter-bridge circuit, if the leadwires are of the same resistance and subjected to the same temperature change, there is essentially no false circuit output due to leadwire thermal effects. Since one of the leadwires is in the active arm of the bridge, and the other is in the dummy arm, the effects of the resistance changes cancel. The remaining error, due to a small change in leadwire desensitization of the gage factor, is normally small enough to be ignored. But this situation is entirely different when a common leadwire arrangement is employed.

The single aspect of common leadwire usage with the most potential for producing serious errors is the loss of leadwire temperature compensation. The copper normally used in leadwires has a rather high thermal coefficient of



Errors Due to Shared Leadwires in Parallel Strain Gage Circuits

resistance. When the common leadwire and the individual leadwires in each of the parallel circuits are subjected to the same change in temperature, false circuit outputs will usually result. This phenomenon occurs because the common leadwire carries the sum of the currents carried by the individual leadwires. Except for a few unique combinations of leadwire resistances, thermally induced resistance changes in the leadwires will produce a different voltage drop in the common and individual return leadwires, thus unbalancing the bridge. If, for example, the active and dummy gages all have the same initial resistance and the resistances of the common and individual return leadwires are the same, then the voltage drop in the common leadwire will be n times as great as in the individual leadwires. Unlike the case of isolated quarter-bridge circuits, these voltage changes do not cancel one another and, as a result, leadwire temperature compensation is lost.

Figure 4 shows the magnitude of the false output increases dramatically with both temperature and number of parallel circuits. These outputs are essentially independent of the strain levels to which the gages are subjected. As a result, loss of temperature compensation can lead to very large percentage errors (or, in extreme cases, even the wrong sign!) when measuring typical working strains.

7.0 Remedial Measures

By far the best remedy for problems created by a common power-supply leadwire is to avoid using it altogether. However, for those cases in which there is no alternative to the common leadwire, several different techniques can be employed to minimize the difficulties. If, for example, the strain indicator can be balanced at the test temperature, and

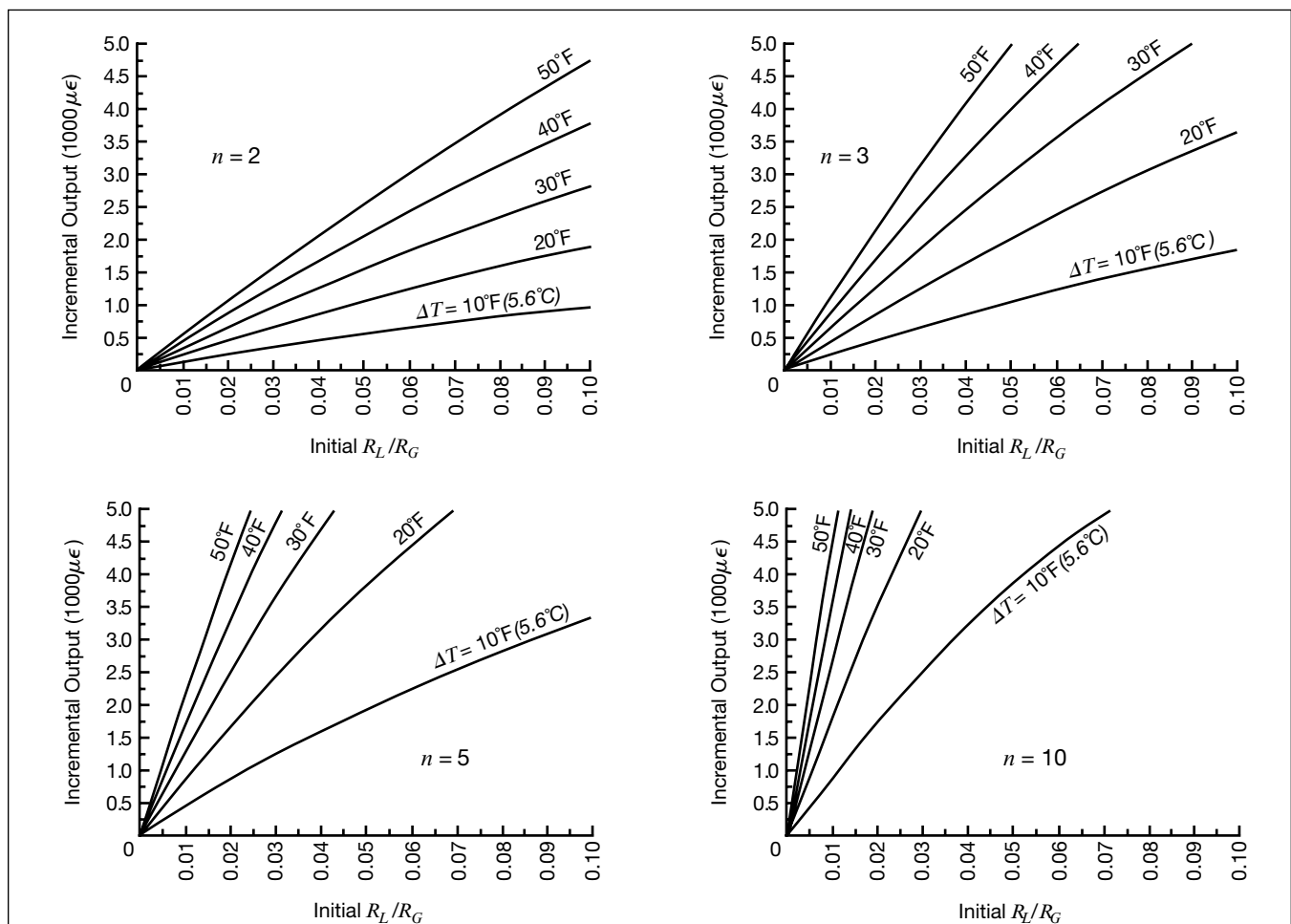

Figure 4. Output increment due to leadwire resistance change with temperature when the resistance of all dummy and active gages is the same, the common and parallel leadwires are all of the same resistance, and the circuit has been shunt calibrated at $1000\mu\epsilon$ across the active gages, assuming a gage factor (package data) of 2.000. Note that any thermal output from the strain gages is not included.

Errors Due to Shared Leadwires in Parallel Strain Gage Circuits

no further temperature changes occur prior to making strain measurements, there will be, of course, no leadwire temperature errors. Although this leaves only the relatively small errors due to crosstalk between parallel circuits, there may still be a problem if the initial imbalance is beyond the balance range of the instrument in use. The latter problem can be overcome by tying the instrument ends of all dummies together at a common point and inserting a fixed precision resistor in series between points D and C in Figure 1. When all leadwires, including the common leadwire, have the same resistance, a series resistor equal to $R_L(n - 1)/n$ will nullify the initial imbalance (and reduce crosstalk).

The most effective remedy is one which eliminates the

initial imbalance while maintaining leadwire temperature compensation, even under varying test temperatures. This is accomplished by selecting a common power-supply leadwire with a resistance $1/n$ times that of the individual return leadwires. Table 1 gives a simple procedure for determining the appropriate wire gauge number to achieve the desired circuit performance. Selection of the common leadwire resistance in this fashion not only solves the initial imbalance and leadwire temperature problems, but also reduces the calibration and crosstalk errors. However, it should be noted that if the resistance of the common leadwire is *less* than $1/n$ times that of the individual return leadwires, then all of the problems described here will be created in reverse.

One simple method of reducing all imbalances and errors is to reduce the ratio R_L/R_G . This can be accomplished by using higher resistance gages when available.

The many problems of a single common leadwire as outlined above can be totally eliminated by using Vishay Micro-Measurements Bridge Completion Modules to move dummy resistors to the gage site, and employing common leadwires for all parallel circuits to both positive and negative terminals of the power supply. For this technique to be effective, both common leadwires must have the same resistance and be subjected to the same changes in temperature. The relatively minor problem of leadwire desensitization remains, but this can be eliminated by shunt calibrating the active or dummy gages. Unfortunately, additional wires are required for remote shunting.

8.0 Summary

The use of a common power-supply leadwire can introduce large errors in strain measurements, along with practical instrumentation problems such as excessive initial imbalance. Unless absolutely necessary, the common power-supply leadwire should be avoided altogether. When a common leadwire must be employed, the user needs to be aware of the error magnitudes, and should always take steps to minimize these errors through selection of the proper leadwire size and, whenever practical, through numerical correction of measured data.

TABLE 1
GAUGE OF COMMON LEADWIRE

Parallel Circuits	AWG Number Reduction	Diameter Ratio (Individual : Common)
2	3 steps	$1:\sqrt{2}$
3	5 steps	$1:\sqrt{3}$
5	7 steps	$1:\sqrt{5}$
10	10 steps	$1:\sqrt{10}$

AWG number of the common leadwire should be reduced from the AWG number of the individual leadwires by the number of integer steps above to minimize initial imbalance and loss of leadwire temperature compensation. This assumes the leadwires are all of the same length and that all dummy and active gages are of the same nominal resistance.

NOTE: This procedure for circuit compensation by wire gauge selection is based on single-conductor (solid) wires, for which there is a well-defined relationship between AWG number and the conductor cross-sectional area. Since the wire is normally drawn to a specified diameter, rather than resistance, precise compensation may require measurement of the wire resistances. The relationship between wire gauge and resistance is still more variable with stranded wire, and the resistance should always be measured to accurately establish the $1/n$ resistance ratio between the common and individual leadwires. In either case, any minor adjustments necessary to obtain the correct resistance for temperature compensation can be made by increasing or decreasing the length of the common leadwire as required.



Errors Due to Shared Leadwires in Parallel Strain Gage Circuits



INTERTECHNOLOGY

1 Scarsdale Road, Don Mills, ON M3B 2R2

Tel: 416-445-5500 Fax: 416-445-1170

TOLL FREE: 1-800-465-1600

E-Mail: sales@intertechnology.com

Website: www.intertechnology.com