

The Three-Wire Quarter-Bridge Circuit

Introduction

Since the invention of the electrical resistance strain gage more than a half century ago, the Wheatstone bridge has become the sensing circuit of choice in most commercially available strain gage instrumentation. This is due in large measure to its inherent ability to:

- 1) detect the small resistance changes produced in the strain gage as it follows even minute dimensional changes on the surface of a test part under load,
- 2) produce a zero output voltage when the test part is at rest, and
- 3) provide for compensation of temperature-induced resistance changes in the strain gage circuit.

To varying degrees, each of these factors is essential for accurate strain gage measurements.

In the majority of strain gage applications for the determination of the state of stress on a test-part surface, individual strain gage elements, whether from uniaxial or rosette strain gage configurations, are connected independently to the Wheatstone bridge in a quarter-bridge arrangement. As discussed in the following sections, the wiring scheme chosen to connect the strain gage to the bridge circuit has a significant effect on the accuracy of measured strain data.

The Wheatstone Bridge

The Wheatstone bridge circuit in its simplest form (Figure 1) consists of four resistive elements, or bridge arms (R_1 , R_2 , R_3 , R_4), connected in a series-parallel arrangement, with an excitation voltage source (E). The connection points formed by (adjacent) pairs of bridge arms and the leadwires from the excitation voltage source are input corners of the bridge; and those formed by pairs of bridge arms and the signal (e_o) measurement leads are output corners. It is worth noting for this discussion that each input corner is adjacent to each output corner, and each bridge arm is connected between two adjacent corners.

Also, if the bridge circuit is resistively symmetrical about an imaginary line drawn through both output corners, the output voltage e_o will be exactly zero, regardless of the excitation voltage level, and the bridge will be “balanced”.

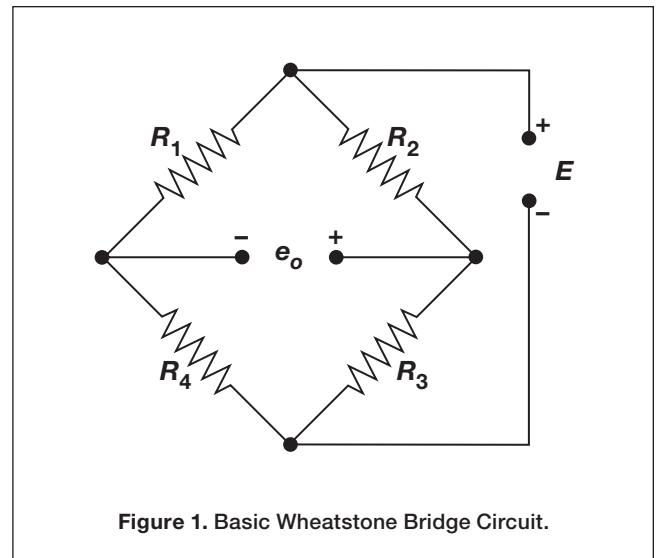

Figure 1. Basic Wheatstone Bridge Circuit.

Two-Wire Circuit

For an initially balanced bridge, if one of the resistors in Figure 1 is replaced with a strain gage of precisely the same resistance value and connected with two leadwires having negligible resistance, the bridge circuit remains at balance. But in practice the leadwires will have some measurable resistance R_L as shown in Figure 2 on page 222. And because both leadwires are in series with the strain gage between adjacent corners of the bridge circuit, the bridge arm resistance becomes $R_G + R_{L1} + R_{L2}$, causing a significant lack of symmetry and an unbalanced condition in the bridge, resulting in a non-zero output voltage at e_o .

If the initial imbalance is modest, it may be mathematically subtracted from subsequent measured strain readings; but large imbalances may cause a more serious problem. As an example, a 20-ft [6 m] length of two-conductor AWG26 [0.4 mm dia.] copper leadwire has a room-temperature resistance value of about 1.7 ohms. Wired in a two-wire connection with a 120-ohm strain gage, and connected to a measuring instrument with a gage factor setting of 2.0, this would produce an initial bridge imbalance corresponding to about $7000\mu\epsilon$. This offset may significantly limit the available measurement range of the instrumentation, and also should be considered when correcting for Wheatstone bridge nonlinearity (see Tech Note TN-507).

The Three-Wire Quarter-Bridge Circuit

Further, the leadwires are a parasitic resistance in the gage arm of the bridge, and effectively reduce or desensitize the gage factor of the strain gage, resulting in a reduced signal output. For modest values of leadwire resistance, the desensitization is approximately equal to the ratio of leadwire resistance to strain gage resistance. In the example given here, this results in about a 1.5% loss in sensitivity.

And finally, a more serious problem may result if the temperature of the leadwires changes during the measurement process. Copper leadwires change in resistance approximately 22% of their room-temperature resistance value for a 100°F [55°C] temperature change. For the 120-ohm gage circuit in Figure 2, this would result in an error equivalent to approximately 156 microstrain, or about 4700 psi [0.03 GPa] in steel, for a 10°F [5.5°C] temperature change in the leadwire system.

All three of these effects increase in severity with increased leadwire resistance. It is worth noting that use of a 350-ohm

strain gage circuit will reduce each of these effects, but cannot eliminate completely the associated measurement errors. But the three-wire circuit described in the following section will reduce the loss in sensitivity, and essentially eliminate the initial imbalance problem and the error that results from temperature changes in the leadwire system.

Three-Wire Circuit

With the three-wire circuit shown in Figure 3, the negative output bridge corner is electrically moved from the top of R_4 , to the bottom strain gage tab at the end of R_{L3} . In this configuration, leadwire R_{L1} and strain gage R_G comprise one arm of the bridge, and R_{L2} with resistor R_4 the adjacent arm. For an equal-arm bridge, if leadwires R_{L1} and R_{L2} are initially the same type and length, their resistances will be equal, and the two respective bridge arms will therefore be equal in resistance. The bridge is resistively symmetrical about a line through the bridge output corners, and the bridge is balanced. And regardless

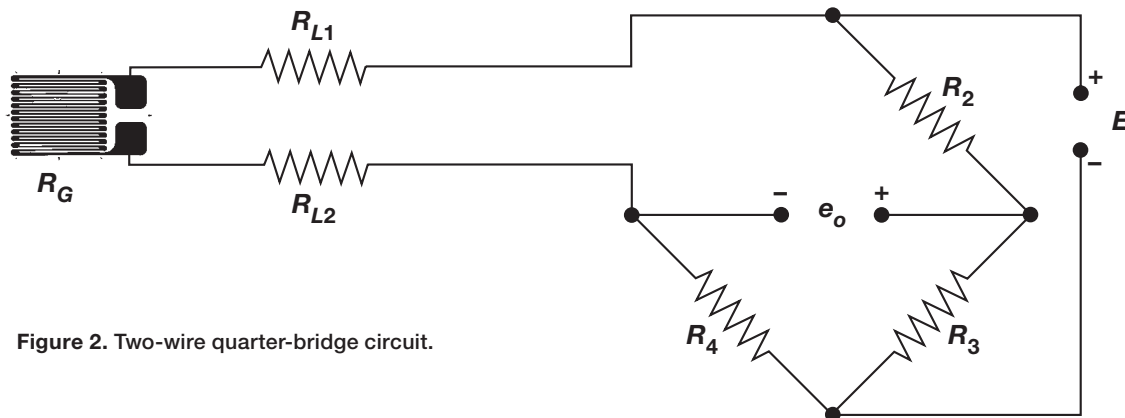

Figure 2. Two-wire quarter-bridge circuit.

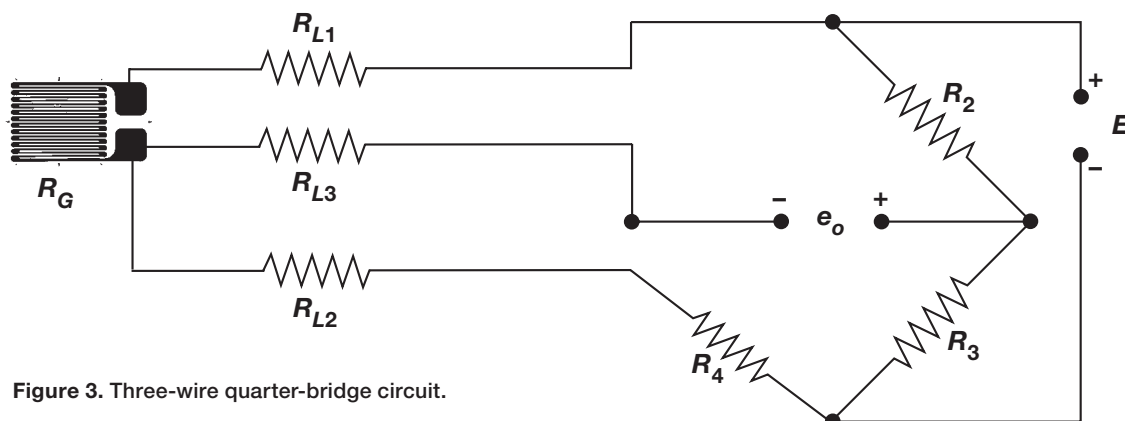

Figure 3. Three-wire quarter-bridge circuit.

The Three-Wire Quarter-Bridge Circuit

of leadwire temperature changes, so long as the two leadwires are at the same respective temperature, the bridge remains in balance. Additionally, because only one leadwire is in series with the strain gage, leadwire desensitization is reduced about 50% compared to the two-wire configuration. The third wire (R_{L3}) in Figure 3 is a voltage-sensing wire only, it is not in series with any of the bridge arms, therefore it has no effect on bridge balance or temperature stability.

While the three-wire circuit offers several advantages over the two-wire circuit, in some special applications involving, for example, slip rings or feed-through connectors, not enough connections may be available for a continuous three-wire system from the gage site to the instrument terminals. In these cases, use of a two-wire lead system between the strain gage and the connector, and a three-wire circuit between the connector and the measuring instrument, is recommended to minimize the total length of the two-wire system.

The foregoing discussion applies primarily to measurement of static strains using a measuring instrument with

dc-coupling between the bridge circuit and the amplifier input terminals. For measurement of purely dynamic strains when only the peak-to-peak amplitude of a time-varying signal is of interest, the two-wire system may sometimes be used effectively by selecting a signal-conditioning amplifier that provides for ac-coupling of the input signal, and blocks the effects of temperature-induced changes in leadwire resistance.

In summary, benefits of the three-wire circuit include intrinsic bridge balance, automatic compensation for the effects of leadwire temperature changes on bridge balance, and increased measurement sensitivity compared to the two-wire configuration. The three-wire hookup is the recommended configuration for quarter-bridge strain gage circuits for static strain measurement. The two-wire circuit can sometimes be used effectively for special situations such as dynamic-only measurements with ac-coupled instrumentation, or in static strain applications where the length of the two-wire system can be kept very short.

